

ATLANTIC VERSION TERMINATOR INTERFACE ADAPTER	PART NUMBER	REVISION	DESCRIPTION	FEED TYPE	APPLICATOR STYLE CONVERSION CHART					
					CONVERT TO	PART NUMBERS REQUIRED				
	2266614-2	A	FINE CRIMP HEIGHT ADJUST	PNEUMATIC	-	-	-	-	-	-
	2266614-5	A	FINE CRIMP HEIGHT ADJUST	SERVO LATCH PLATE	SERVO LATCH PLATE 2119951-1	-	8-2266614-5	1901094-3	2-1752354-8	2168400-6 (QUANTITY 2)
	2266614-6	A	NON-CRIMP HEIGHT ADJUST	SERVO LATCH PLATE	SMART APPLICATOR 2161326-1	-	8-2266614-4	-	-	-
	2266614-7	A	FINE CRIMP HEIGHT ADJUST	NONE	-	-	-	-	-	-
	7-2266614-7	A	CRIMP TOOLING KIT	-	-	-	-	-	-	-

APPLICATOR DATA		
CRIMP	SIZE	TYPE
WIRE	3.85 mm [1.52]	F
INSUL	6.60 mm [2.60]	O

APPLICATOR INSTRUCTIONS 408-10389

TERMINAL DATA: FCI TERMINAL		FCI CRIMP SPECIFICATION	
TERMINAL NAME: TERMINAL, MALE			
WIRE STRIP LENGTH		INSULATION DIAMETER RANGE	
7.50-8.50 mm [2.95-.335 IN]		$\varnothing$	$\Delta$ 1.3
TERMINAL APPLICATION SPECIFICATION	9084-0600 Rev D	-	-
TERMINALS APPLIED			
TE TERMINAL	FCI TERMINAL	TE SEAL	FCI SEAL
1572472-1	6017-0261	1572474-1	60993301
INSULATION RANGE $\varnothing$ 3.50-5.50mm [ $\varnothing$ .138-.217 IN]			

WIRE SIZE	CRIMP HEIGHT mm [INCH]	CRIMP HEIGHT REFERENCE SETTING
6.00mm2	2.80 +/- 0.05 [1.110 +/- .002]	5.2
5.00mm2	2.70 +/- 0.05 [1.06 +/- .002]	6.4
10 AWG	2.55 +/- 0.05 [1.00 +/- .002]	8.0
4.00mm2	2.30 +/- 0.05 [1.091 +/- .002]	10.7

- RECOMMENDED SPARE PARTS
- GREASE BEARING SURFACES LIGHTLY
- 3. LUBRICATE DAILY PER THE APPLICATOR INSTRUCTION SHEET SUPPLIED WITH THE APPLICATOR.
- APPLICATOR SPECIFIC DATA TO BE ENTERED INTO BLANK MEMORY CHIP AT ASSEMBLY. SEE BELOW FOR PART NUMBER:  
 PNEUMATIC FEED WITH "SMART APPLICATOR" CONVERSION: 8-2266614-4  
 SERVO FEED WITH "FINE CRIMP HEIGHT ADJUST": 8-2266614-5  
 SERVO FEED WITH "NON-CRIMP HEIGHT ADJUST": 8-2266614-6
- 5. ADJUSTMENT OF THE STRIPPER MAY BE REQUIRED WHEN MOVING THE APPLICATOR BETWEEN BENCH AND LEADMAKER APPLICATIONS.
- APPLY PART NUMBER 1-23419-5 LOCTITE TO THREADS OF ITEMS 62 & 180. APPLY PART NUMBER 2-23419-6 LOCTITE TO THREADS OF ITEM 242. FOR -6 ONLY APPLY PART NUMBER 1-23419-5 LOCTITE TO THREADS OF ITEMS 37 & 180.
- GREASE THREADS, GROOVE AND O-RING ON ITEMS 35 & 252.
- MAGNET, ITEM 166 MUST BE ORIENTED CORRECTLY IN ORDER TO PROPERLY ACTUATE THE COUNTER.
- CRIMP HEIGHT REFERENCE SETTING WAS THE SETTING USED WHEN THE APPLICATOR WAS QUALIFIED AT THE FACTORY. ADJUSTMENT MAY BE NECESSARY WHEN RUNNING APPLICATOR IN THE FIELD.
- TERMINAL PITCH NOT COMPATIBLE WITH MECHANICAL FEED.
- TO CONVERT THE APPLICATOR TO A NON-CARRIER CUTTING STYLE, REMOVE ITEM 13 AND ATTACH TO THE LOCATION ON THE BACK SIDE OF THE HOUSING. REFER TO INSTRUCTION SHEET FOR ADDITIONAL INFORMATION.
- WHEN ASSEMBLING A NON CRIMP HEIGHT ADJUST APPLICATOR (-6) USE SHIMS FROM ITEM 260 TO ACHIEVE A NOMINAL SHIM HEIGHT OF 3.00.
- THIS APPLICATOR APPLIES TERMINAL WITH A SEAL.
- APPLY TORQ-SEAL IN ALLEN SOCKET TO FILL HOLE AFTER FLAT HD HAS BEEN ADJUSTED TO CORRECT HEIGHT AT QUALIFICATION. APPLY #1-23419-5 LOC-TITE TO THREADS.
- CUT TO LENGTH AT ASSEMBLY.

**\*WARNING**  
 ON INSTALLATION, SET WIRE DISC, ITEM 40 TO LARGEST WIRE SIZE SETTING. USE OF SETTINGS BELOW MINIMUM REQUIRED CRIMP HEIGHT SETTING WILL CAUSE DAMAGE TO CRIMP TOOLING.

-	1	1	1	1	455888-5	SPACER, CRIMPER	270
-	2	2	2	2	2168083-1	SCR, SKT HD CAP, RoHS, M3 X 8.0	269
-	1	1	1	1	1633782-4	FENCE	267
-	1	1	1	1	2119957-2	APPLICATOR SHIM PACK	260
-	1	1	1	1	1803078-2	SPACER, PRECISION	259
-	1	-	1	1	8-21084-0	O-RING, .676 ID, .070 DIA. MAT.	252
-	-	-	-	1	2119640-1	PUSH ROD, AIR FEED	250
-	-	-	-	1	2079988-1	BUSHING, LCH5-12, MISUMI	249
-	-	-	-	1	2119641-1	FEED CAM, AIR FEED	248
-	1	-	1	1	2119798-1	DETENT PIN	247
-	1	-	1	1	1-22279-3	SPRING, COMPRESSION	246
-	-	1	-	-	2161314-1	RAM, STEPPED, ATLANTIC, SF, NON-ADJ	245
-	1	1	1	1	2119082-5	CAM, SNAIL, INSULATION ADJUSTMENT	244
-	1	1	1	1	2079764-1	WASHER, WAVE SPRING, CREST-TO-CREST	243
-	1	1	1	1	2119083-1	RETAINER, INSULATION DIAL	242
-	1	1	1	1	7-18023-7	SCR, SKT HD CAP M3 X 4.0	241
-77	-7	-6	-5	-2	PART NO	DESCRIPTION	ITEM NO

**ATLANTIC VERSION**  
 Shown on sheets 1 of 4 & 2 of 4  
 (Pacific version shown on sheets 3 of 4 & 4 of 4)

SET UP GAUGE	LOC	DIST	REVISIONS					
2119599-1	A	66	P	LTN	DESCRIPTION	DATE	OWN	APVD
			A	RELEASED		06MAR2015	BW	TE

-	-	2	2	-	2168400-6	SHCS, LOW HEAD, RoHS, M5 X 16	240
-	-	-	-	-	2119580-1	MECHANICAL FEED ASSEMBLY	239
-	-	-	-	1	2063440-2	AIR FEED MODULE	238
-	-	1	1	-	2119740-2	TAG, IDENTIFICATION	213
-	-	1	1	-	1901094-3	SPACER, FEEDER	198
-	1	1	1	1	2-1752354-8	STANDOFF, HOLD-DOWN	180
-	1	1	1	1	6-993111-6	PIN, SLOTTED SPRING 3.0 X 14.0	177
-	1	1	1	1	8-22280-7	SPRING, COMPRESSION	176
-	1	1	1	1	1752353-2	GUIDE PIN, HOLDDOWN	175
-	1	1	1	1	1901680-2	GUIDE PIN, HOLDDOWN	174
-	-	-	-	2	21045-3	RING, RETAIN, EXTERN, 3/16 CRESCENT	172
-	1	1	1	1	994969-1	MAGNET, RARE EARTH HIGH ENERGY	166
-	REF	REF	REF	REF	994970-2	COUNTER, MAGNETIC	164
-	-	-	-	1	240638-1	SPRING, FEED FINGER	163
-	-	-	-	1	3-23627-7	PIN, RETAIN, GRVD, 3/16 X .854	137
-	-	-	-	1	2119799-1	HOLDER, FEED FINGER, AF	136
-	-	REF	REF	-	SEE NOTE 4	MEMORY CHIP, PROGRAMMED	135
-	-	1	1	-	1633743-1	SERVO FEED LATCH ASM	133
-	-	REF	REF	-	2119944-1	FEED FINGER ASSEMBLY, SF	117
-	1	1	1	1	1-690438-0	FRONT STRIP GUIDE	96
-	1	1	1	1	318563-1	GUARD, FRONT CHIP	89
-	1	1	1	1	1-455888-1	SPACER, CRIMPER	82
-	1	1	1	1	1803096-1	EXTENSION PLATE	78
-	1	1	1	1	2119956-1	DOCUMENTATION PACKAGE	71
-	1	1	1	1	2119791-7	DEPRESSOR, WIRE	70
-	1	1	1	1	2119943-1	WASHER, SPACER	69
-	1	-	-	1	2119740-1	TAG, IDENTIFICATION	67
-	2	2	2	2	2168078-1	SCREW, DRIVE, RH, RoHS, 2 x .188	66
-	1	-	1	1	2119793-1	LIMITER, ADJUSTMENT BOLT	63
-	3	3	3	3	992763-5	SCR, SET, SOC, CONE POINT, M3 X 4.0	62
-	3	3	3	3	2079383-4	SCR, BHSC, RoHS (M4 X 8)	60
-	-	-	-	1	5-18022-5	SCR, HEX HD CAP, M4 X 6.0	59
-	1	1	1	1	1-2168083-3	SCR, SKT HD CAP, RoHS, M3 X 16	57
-	-	-	-	1	1338683-8	FEED PAWL	56
-	4	4	4	4	2168400-1	SHCS, LOW HEAD, RoHS, M4 X 12	54
-	1	1	1	1	1-5018030-0	NUT, HEX, REG, RoHS, M3.5	52
-	1	1	1	1	1-1901681-3	HOLDDOWN, TERMINAL	51
-	-	-	-	1	18023-9	SCR, SKT HD CAP M4 X 6.0	49
-	-	-	-	-	2119652-1	FEED CAM, PRE FEED	48
-	-	-	-	-	2119653-1	FEED CAM, POST FEED	47
-	1	1	1	1	1-2119656-7	APPLICATOR BASIC ASSEMBLY, SF	46
-	1	-	1	1	2161311-1	RAM, STEPPED, AMP STYLE, SIDE FEED	44
-	1	1	1	1	1-2079383-5	SCR, BHSC, RoHS (M8 X 40)	41
-	1	-	1	1	2119645-1	DISC, NUMBERED FA WIRE ADJUSTMENT	40
-	1	-	1	1	2119957-1	APPLICATOR SHIM PACK	39
-	1	1	1	1	2119644-3	RAM WASHER, PRECISION	38
-	1	1	1	1	2119085-1	FA HEAD, ATLANTIC STYLE	37
-	1	-	1	1	2119092-1	BOLT, ADJUSTMENT	35
-	1	1	1	1	1-1752356-8	SUPPORT, TERMINAL	34
-	2	2	2	2	2079383-5	SCR, BHSC, RoHS (M4 X 20)	33
-	1	1	1	1	2161328-1	HEX HEAD, FLANGED, M5 X 8mm LONG	32
-	1	1	1	1	1320908-6	SPACER, STRIP GUIDE	30
-	1	1	1	1	2119959-6	ASSEMBLY, STRIP GUIDE	29
-	1	1	1	1	2-455888-0	SPACER, CRIMPER	28
-	2	2	2	2	22283-1	SPRING, COMPRESSION	27
-	1	1	1	1	240792-1	DRAG, TERMINAL	25
-	1	1	1	1	1320928-2	STRIP GUIDE	24
-	1	1	1	1	2168083-2	SCR, SKT HD CAP, RoHS, M4 X 8.0	21
-	1	1	1	1	1-18028-2	WASHER, FLAT, REG M4	20
-	1	1	1	1	2119533-1	STRIPPER, SIDE FEED	19
-	1	1	1	1	2119806-1	INSERT, SHEAR	13
-	1	1	1	1	4-22280-7	SPRING, COMPRESSION	12
-	1	1	1	1	1-356885-3	STOP, SHEAR	11
-	1	1	1	1	2119805-3	SHEAR HOLDER, FRONT	10
-	1	1	1	1	318059-9	FLOATING SHEAR, FRONT	9
1	1	1	1	1	3-1633930-1	ANVIL, COMBINATION	8
-	-	-	-	-	-	-	7
-	-	-	-	-	-	-	6
-	1	1	1	1	1803080-1	DEPRESSOR, SHEAR	5
-	1	1	1	1	2-238011-1	BLOCK, CRIMPER SPACER	4
1	1	1	1	1	2-2119784-5	CRIMPER, INSULATION O PREMIUM	3
-	1	1	1	1	1-455888-1	SPACER, CRIMPER	2
1	1	1	1	1	7-1633664-8	CRIMPER, WIRE	1
-77	-7	-6	-5	-2	PART NO	DESCRIPTION	ITEM NO

DIMENSIONS:		TOLERANCES UNLESS OTHERWISE SPECIFIED:		OWN	DATE	NAME	TE Connectivity Harrisburg, PA 17105-3608				
mm	0 PLC ±.5 1 PLC ±.13 2 PLC ±.13 3 PLC ±.013 4 PLC ±.001 ANGLES ±.1	FINISH		WEAVER	12DEC2014			Ocean Side Feed Applicator	RESTRICTED TO		
MATERIAL				ELBIN	12DEC2014	SIZE	CAGE CODE			DRAWING NO	SHEET
						A1	00779	2266614	1	4	A

Customer Accessible Production Drawing SCALE 1:2 SHEET 1 OF 4

LOC	DIST	REV	DATE	BY	APPV
A	66				

REVISIONS			
REV	DATE	BY	APPV
-	SEE SHEET 1	-	-

### FEED TYPE

### PNEUMATIC

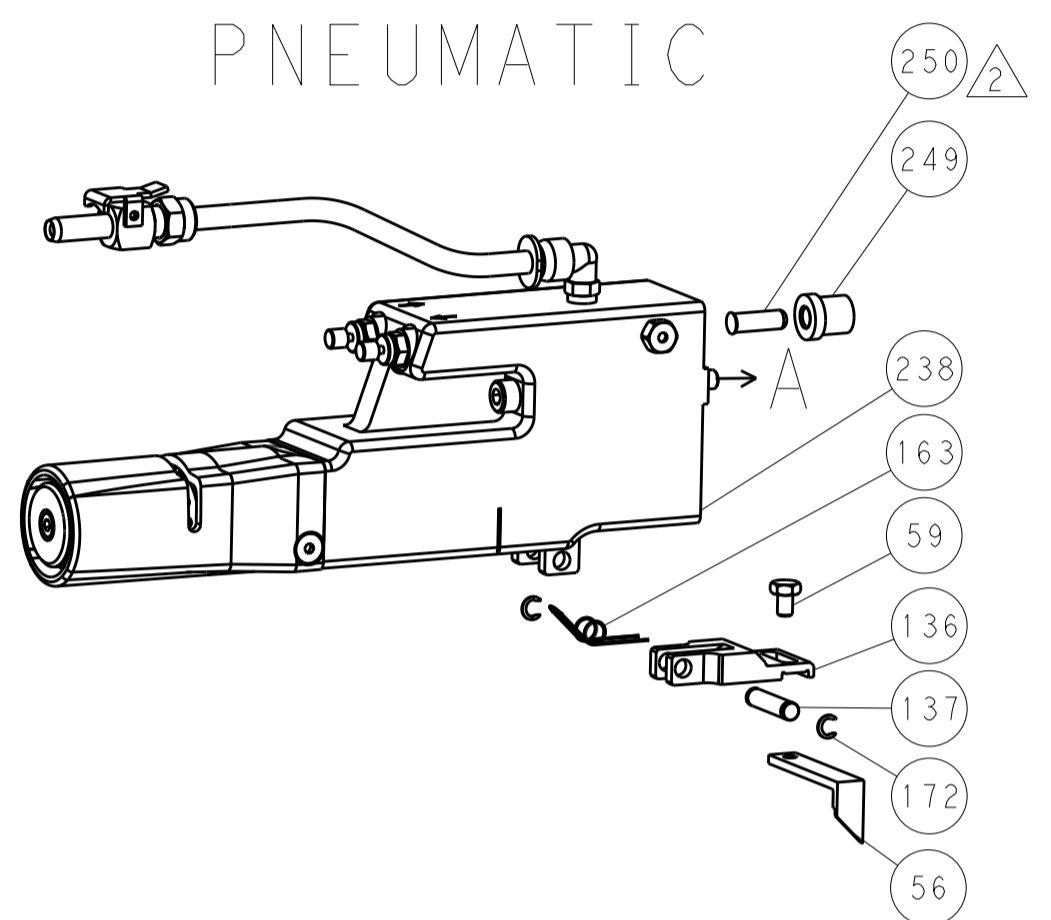

### SERVO LATCH PLATE

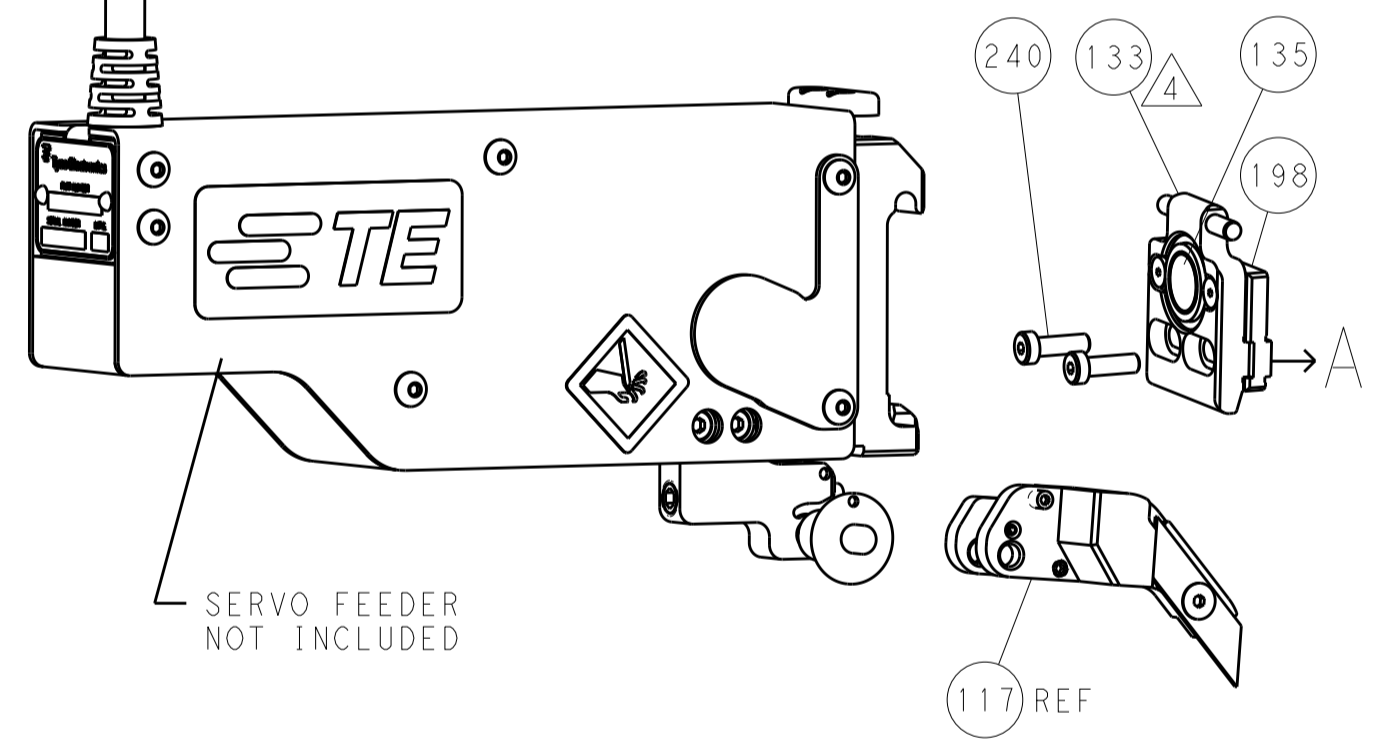

### CAM POSITION

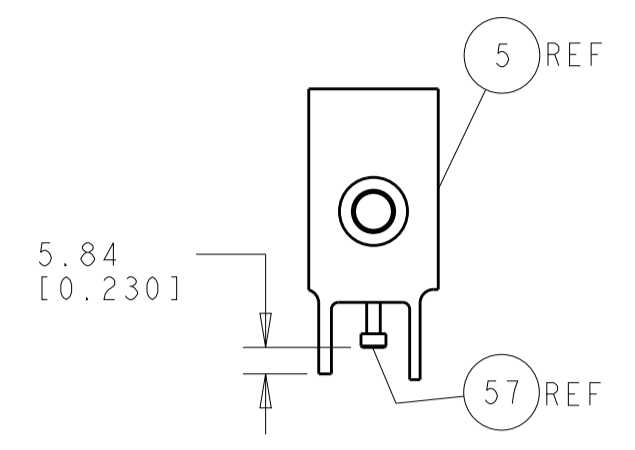
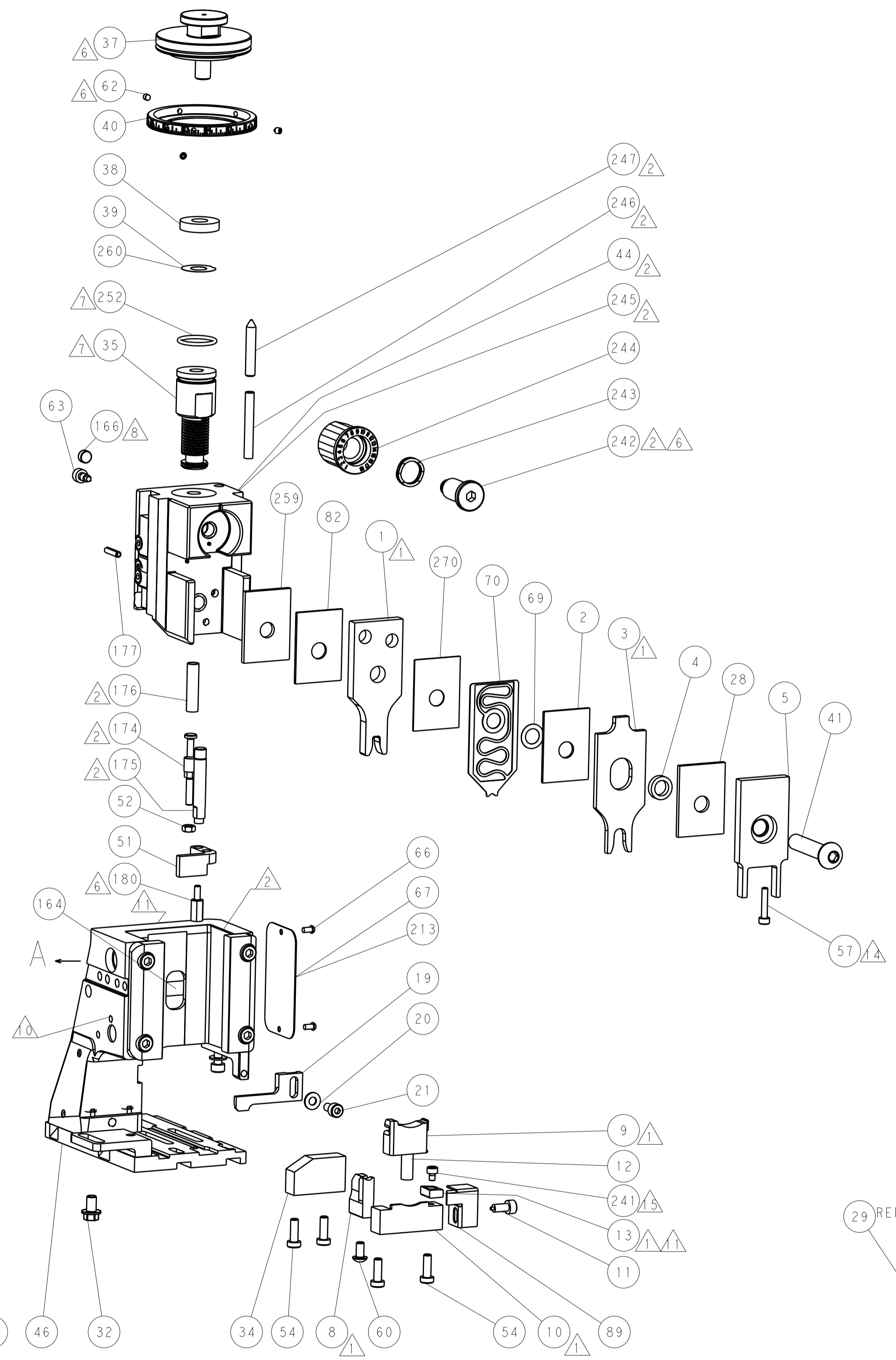
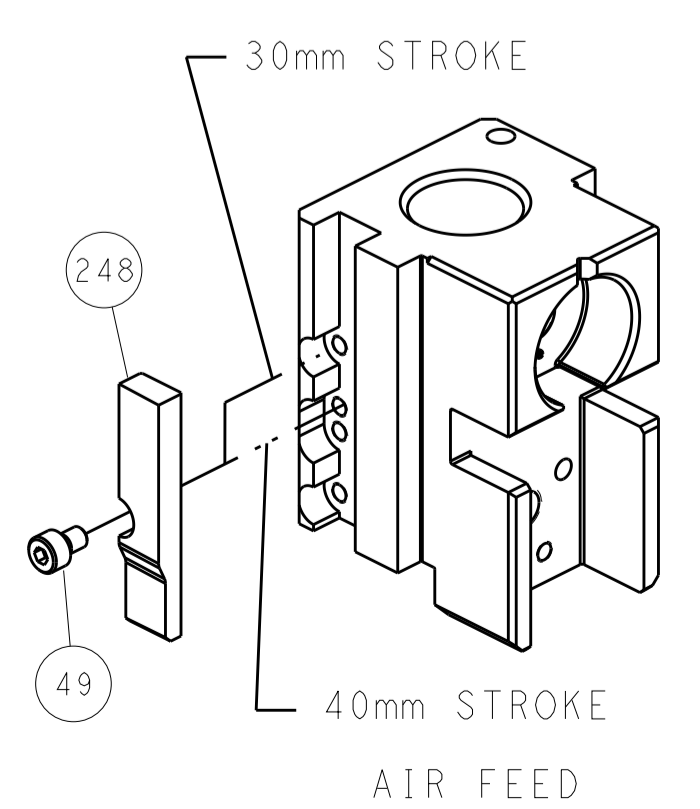

SHEAR DEPRESSOR DETAIL

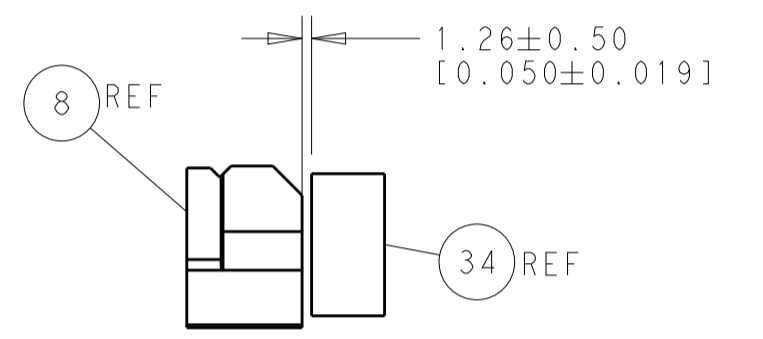

TERMINAL SUPPORT LOCATION

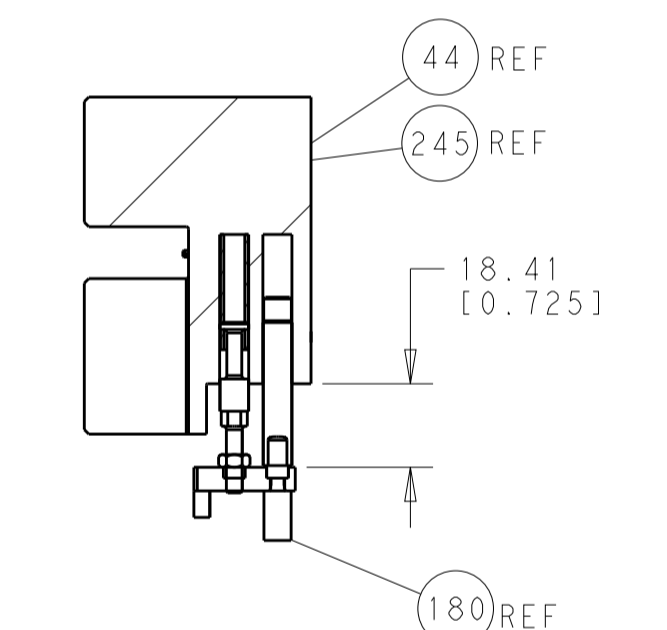

HOLDDOWN SET-UP

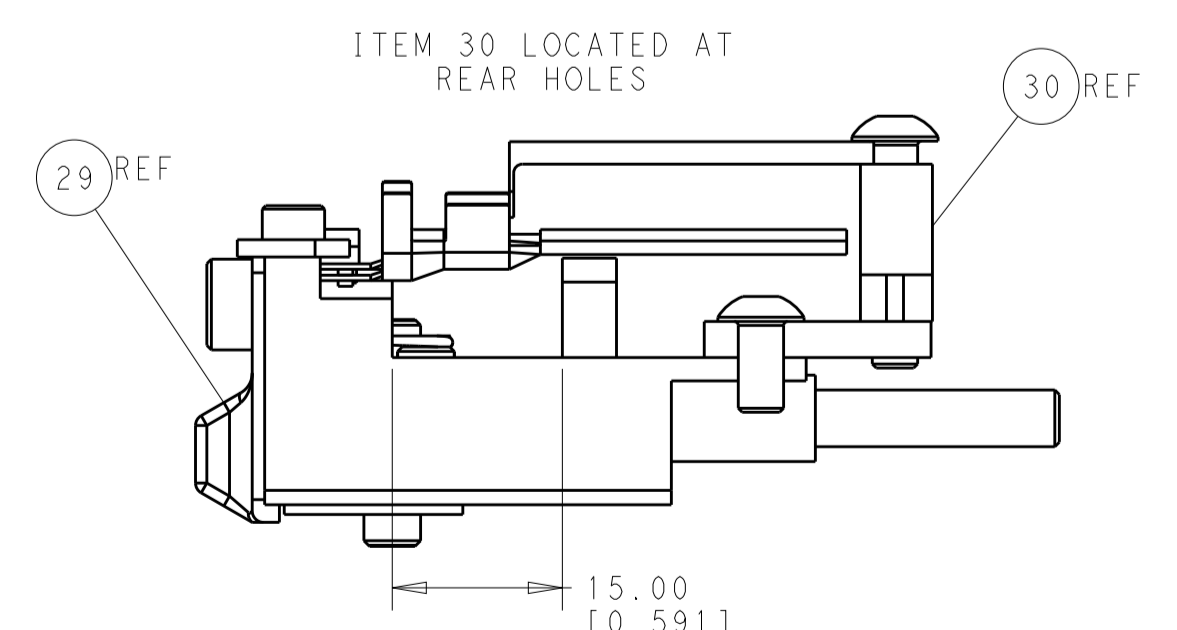

FEED TRACK POSITION GUIDE BY WIRE BARREL

**ATLANTIC VERSION**  
 Shown on sheets 1 of 4 & 2 of 4  
 (Pacific version shown on sheets 3 of 4 & 4 of 4)

DIMENSIONS:		TOLERANCES UNLESS OTHERWISE SPECIFIED:		DWG: B. WEAVER 12DEC2014		TE Connectivity	
mm	0 PLC ±0.5	1 PLC ±0.5	2 PLC ±0.13	3 PLC ±0.013	4 PLC ±0.001	APVD: T. ELBIN 12DEC2014	Harrisburg, PA 17105-3608
MATERIAL:		FINISH:		NAME: Ocean Side Feed Applicator		RESTRICTED TO:	
Customer Accessible Production Drawing		SCALE: 1:2		SHEET 2 OF 4		REV A	

PACIFIC VERSION TERMINATOR INTERFACE ADAPTER	PART NUMBER	REVISION	DESCRIPTION	FEED TYPE
	2-2266614-2	A	FINE CRIMP HEIGHT ADJUST	PNEUMATIC
	2-2266614-5	A	FINE CRIMP HEIGHT ADJUST	SERVO LATCH PLATE <sup>4</sup>
	2-2266614-7	A	FINE CRIMP HEIGHT ADJUST	NONE
	7-2266614-7	A	CRIMP TOOLING KIT	-

APPLICATOR DATA		
CRIMP	SIZE	TYPE
WIRE	3.85 mm [1.52]	F
INSUL	6.60 mm [2.60]	O
APPLICATOR INSTRUCTIONS 408-10389		

TERMINAL DATA: FCI TERMINAL		FCI CRIMP SPECIFICATION	
TERMINAL NAME: TERMINAL, MALE			
WIRE STRIP LENGTH		INSULATION DIAMETER RANGE	
7.50-8.50 mm [1.295-.335 IN]			
TERMINAL APPLICATION SPECIFICATION	9084-0600 Rev D		
TERMINALS APPLIED <sup>10</sup>			
TE TERMINAL	FCI TERMINAL	TE SEAL	FCI SEAL
1572472-1	6017-0261	1572474-1	60993301
INSULATION RANGE Ø 3.50-5.50mm [Ø .138-.217 IN]			

WIRE SIZE	CRIMP HEIGHT mm [INCH]	CRIMP HEIGHT REFERENCE SETTING
6.00mm2	2.80 +/- 0.05 [1.10 +/- .002]	5.2
5.00mm2	2.70 +/- 0.05 [1.06 +/- .002]	6.4
10 AWG	2.55 +/- 0.05 [1.00 +/- .002]	8.0
4.00mm2	2.30 +/- 0.05 [0.91 +/- .002]	10.7



- <sup>1</sup> RECOMMENDED SPARE PARTS
- <sup>2</sup> GREASE BEARING SURFACES LIGHTLY
3. LUBRICATE DAILY PER THE APPLICATOR INSTRUCTION SHEET SUPPLIED WITH THE APPLICATOR.
- <sup>4</sup> APPLICATOR SPECIFIC DATA TO BE ENTERED INTO BLANK MEMORY CHIP AT ASSEMBLY. SEE BELOW FOR PART NUMBER:  
PNEUMATIC FEED WITH "SMART APPLICATOR" CONVERSION: 8-2266614-4  
SERVO FEED WITH "FINE CRIMP HEIGHT ADJUST": 8-2266614-5
5. ADJUSTMENT OF THE STRIPPER MAY BE REQUIRED WHEN MOVING THE APPLICATOR BETWEEN BENCH AND LEADMAKER APPLICATIONS.
- <sup>6</sup> APPLY PART NUMBER 1-23419-5 LOCTITE TO THREADS OF ITEMS 62 & 180.  
APPLY PART NUMBER 2-23419-6 LOCTITE TO THREADS OF ITEM 242.
- <sup>7</sup> GREASE THREADS, GROOVE AND O-RING ON ITEMS 139 & 152.
- <sup>8</sup> MAGNET MUST BE ORIENTED CORRECTLY IN ORDER TO PROPERLY ACTUATE THE COUNTER.
- <sup>9</sup> CRIMP HEIGHT REFERENCE SETTING WAS THE SETTING USED WHEN THE APPLICATOR WAS QUALIFIED AT THE FACTORY. ADJUSTMENT MAY BE NECESSARY WHEN RUNNING APPLICATOR IN THE FIELD.
- <sup>10</sup> TERMINAL PITCH NOT COMPATIBLE WITH MECHANICAL FEED.
- <sup>11</sup> TO CONVERT THE APPLICATOR TO A NON-CARRIER CUTTING STYLE, REMOVE ITEM 13 AND ATTACH TO THE LOCATION ON BACK SIDE OF THE HOUSING. REFER TO INSTRUCTION SHEET FOR ADDITIONAL INFORMATION.
- <sup>12</sup> THIS APPLICATOR APPLIES TERMINAL WITH A SEAL.
- <sup>13</sup> APPLY TORO-SEAL IN ALLEN SOCKET TO FILL HOLE AFTER FLAT HD HAS BEEN ADJUSTED TO CORRECT HEIGHT AT QUALIFICATION.  
APPLY #1-23419-5 LOC-TITE TO THREADS.
- <sup>14</sup> CUT TO LENGTH AT ASSEMBLY.

**\*WARNING**  
ON INSTALLATION, SET WIRE DISC, ITEM 40 TO LARGEST WIRE SIZE SETTING. USE OF SETTINGS BELOW MINIMUM REQUIRED CRIMP HEIGHT SETTING WILL CAUSE DAMAGE TO CRIMP TOOLING.

-	1	1	1	455888-5	SPACER, CRIMPER	270
-	2	2	2	2168083-1	SCR, SKT HD CAP, RoHS, M3 X 8.0	269
-	1	1	1	1633782-4	FENCE	267
-	1	1	1	1803078-2	SPACER, PRECISION	259
-	1	1	1	2119782-1	FINE ADJUST HEAD ASM, PACIFIC STYLE	251
-	-	-	1	2119640-1	PUSH ROD, AIR FEED	250
-	-	-	1	2079988-1	BUSHING, LCH5-12, MISUMI	249
-	1	1	1	1-22279-3	SPRING, COMPRESSION	246
-	1	1	1	2119082-5	CAM, SNAIL, INSULATION ADJUSTMENT	244
-	1	1	1	2079764-1	WASHER, WAVE SPRING, CREST-TO-CREST	243
-	1	1	1	2119083-1	RETAINER, INSULATION DIAL	242
-	1	1	1	7-18023-7	SCR, SKT HD CAP M3 X 4.0	241
-	-	2	-	2168400-6	SHCS, LOW HEAD, RoHS, M5 X 16	240
-	-	-	-	2119580-1	MECHANICAL FEED ASSEMBLY	239
-	-	-	1	2063440-2	AIR FEED MODULE	238
-77	-27	-25	-22	PART NO	DESCRIPTION	ITEM NO

**PACIFIC VERSION**  
Shown on sheets 3 of 4 & 4 of 4  
(Atlantic version shown on sheets 1 of 4 & 2 of 4)

SET UP GAUGE	LOC	DIST	REVISIONS					
2119599-1	A	66	P	LTM	DESCRIPTION	DATE	OWN	APVD
			-	-	SEE SHEET 1	-	-	-

-	-	1	-	2119740-2	TAG, IDENTIFICATION	213
-	-	1	-	1901094-3	SPACER, FEEDER	198
-	1	1	1	2-1752354-8	STANDOFF, HOLD-DOWN	180
-	1	1	1	6-993111-6	PIN, SLOTTED SPRING 3.0 X 14.0	177
-	1	1	1	8-22280-7	SPRING, COMPRESSION	176
-	1	1	1	1752353-2	GUIDE PIN, HOLDDOWN	175
-	1	1	1	1901680-2	GUIDE PIN, HOLDDOWN	174
-	-	-	2	21045-3	RING, RETAIN, EXTERN, 3/16 CRESCENT	172
-	1	1	1	994969-1	MAGNET, RARE EARTH HIGH ENERGY	166
-	REF	REF	REF	994970-2	COUNTER, MAGNETIC	164
-	-	-	1	240638-1	SPRING, FEED FINGER	163
-	1	1	1	8-21084-1	O-RING, .801 ID, .070 DIA. MAT.	152
-	-	-	1	2119641-2	FEED CAM, AIR FEED	151
-	1	1	1	2119798-2	DETENT PIN	145
-	1	1	1	2079383-8	SCR, BHSC, RoHS (M4 X 16)	144
-	4	4	4	2168400-5	SHCS, LOW HEAD, RoHS, M4 X 20	143
-	-	-	-	2119653-2	FEED CAM, POST FEED	142
-	1	1	1	1-2119656-8	APPLICATOR BASIC ASSEMBLY, SF	141
-	1	1	1	2161312-1	RAM, STEPPED, ASIAN STYLE, SIDE FEED	140
-	1	1	1	2119092-2	BOLT, ADJUSTMENT	139
-	-	-	1	3-23627-7	PIN, RETAIN, GRVD, 3/16 X .854	137
-	-	-	1	2119799-1	HOLDER, FEED FINGER, AF	136
-	-	REF	-	SEE NOTE 4	MEMORY CHIP, PROGRAMMED	135
-	-	1	-	1633743-1	SERVO FEED LATCH ASM	133
-	-	REF	-	2119944-1	FEED FINGER ASSEMBLY, SF	117
-	1	1	1	1-690438-0	FRONT STRIP GUIDE	96
-	1	1	1	318563-1	GUARD, FRONT CHIP	89
-	1	1	1	1-455888-1	SPACER, CRIMPER	82
-	1	1	1	1803096-1	EXTENSION PLATE	78
-	1	1	1	2119956-1	DOCUMENTATION PACKAGE	71
-	1	1	1	2119791-7	DEPRESSOR, WIRE	70
-	1	1	1	2119943-1	WASHER, SPACER	69
-	1	-	1	2119740-1	TAG, IDENTIFICATION	67
-	2	2	2	2168078-1	SCREW, DRIVE, RH, RoHS, 2 x .188	66
-	1	1	1	2119793-1	LIMITER, ADJUSTMENT BOLT	63
-	3	3	3	992763-5	SCR, SET, SOC, CONE POINT, M3 X 4.0	62
-	2	2	2	2079383-4	SCR, BHSC, RoHS (M4 X 8)	60
-	-	-	1	5-18022-5	SCR, HEX HD CAP, M4 X 6.0	59
-	1	1	1	1-2168083-3	SCR, SKT HD CAP, RoHS, M3 X 16	57
-	-	-	1	1338683-8	FEED PAWL	56
-	1	1	1	1-5018030-0	NUT, HEX, REG, RoHS, M3.5	52
-	1	1	1	1-1901681-3	HOLDDOWN, TERMINAL	51
-	-	-	1	18023-9	SCR, SKT HD CAP M4 X 6.0	49
-	-	-	-	2119652-1	FEED CAM, PRE FEED	48
-	1	1	1	1-2079383-5	SCR, BHSC, RoHS (M8 X 40)	41
-	1	1	1	2119645-1	DISC, NUMBERED FA WIRE ADJUSTMENT	40
-	1	1	1	2119957-1	APPLICATOR SHIM PACK	39
-	1	1	1	2119644-3	RAM WASHER, PRECISION	38
-	1	1	1	1-1752356-8	SUPPORT, TERMINAL	34
-	2	2	2	2079383-5	SCR, BHSC, RoHS (M4 X 20)	33
-	1	1	1	2161328-1	HEX HEAD, FLANGED, M5 X 8mm LONG	32
-	1	1	1	1320908-6	SPACER, STRIP GUIDE	30
-	1	1	1	2119959-6	ASSEMBLY, STRIP GUIDE	29
-	1	1	1	2-455888-0	SPACER, CRIMPER	28
-	2	2	2	22283-1	SPRING, COMPRESSION	27
-	1	1	1	240792-1	DRAG, TERMINAL	25
-	1	1	1	1320928-2	STRIP GUIDE	24
-	1	1	1	2168083-2	SCR, SKT HD CAP, RoHS, M4 X 8.0	21
-	1	1	1	1-18028-2	WASHER, FLAT, REG M4	20
-	1	1	1	2119533-1	STRIPPER, SIDE FEED	19
-	1	1	1	2119806-1	INSERT, SHEAR	13
-	1	1	1	4-22280-7	SPRING, COMPRESSION	12
-	1	1	1	1-356885-3	STOP, SHEAR	11
-	1	1	1	2119805-3	SHEAR HOLDER, FRONT	10
-	1	1	1	318059-9	FLOATING SHEAR, FRONT	9
-	1	1	1	3-1633930-1	ANVIL, COMBINATION	8
-	-	-	-	-	-	7
-	-	-	-	-	-	6
-	1	1	1	1803080-1	DEPRESSOR, SHEAR	5
-	1	1	1	2-238011-1	BLOCK, CRIMPER SPACER	4
-	1	1	1	2-2119784-5	CRIMPER, INSULATION O PREMIUM	3
-	1	1	1	1-455888-1	SPACER, CRIMPER	2
-	1	1	1	7-1633664-8	CRIMPER, WIRE	1
-77	-27	-25	-22	PART NO	DESCRIPTION	ITEM NO

DIMENSIONS:		TOLERANCES UNLESS OTHERWISE SPECIFIED:		DRAWN BY		DATE	
mm	0 PLC ±.5	1 PLC ±.5	2 PLC ±.5	WEAVER	12DEC2014		
	3 PLC ±.13	4 PLC ±.013	ANGLES ±.0001	ELBIN	12DEC2014		
	FINISH			ELBIN	12DEC2014		
MATERIAL		WEIGHT		Customer Accessible Production Drawing			
				SCALE	SHEET	OF	REV
				1:2	3	4	A

