

REVISIONS

P	LTR	DESCRIPTION	DATE	DWN	APVD
A		NEW DRAWING	30OCT2008	SG	RJ
C		ECR-10-001257	19JAN2010	Sche	CB
C1		ECR-13-003504	25FEB2013	M.F.	M.G.
C2		ADDED 963142-4 ECR-17-017752	30NOV2020	MAH.	AM

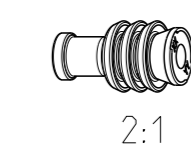
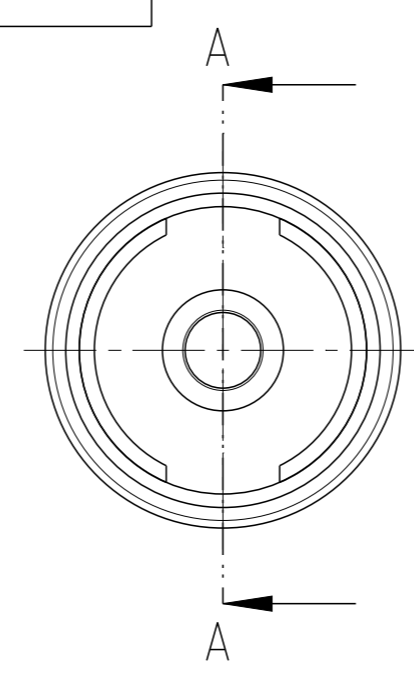
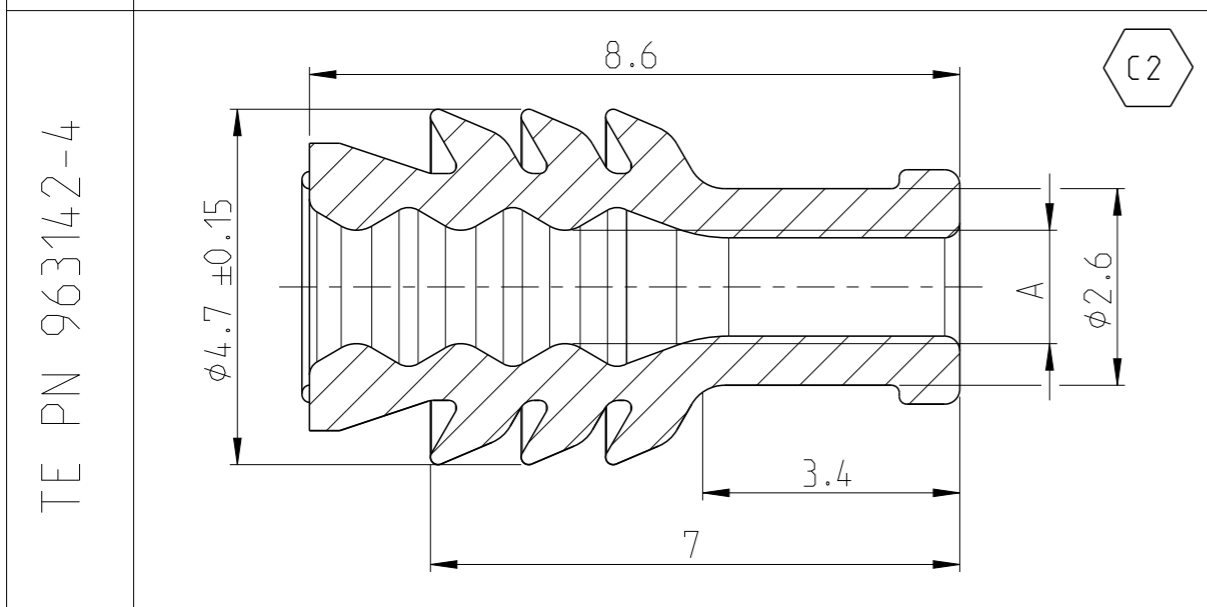
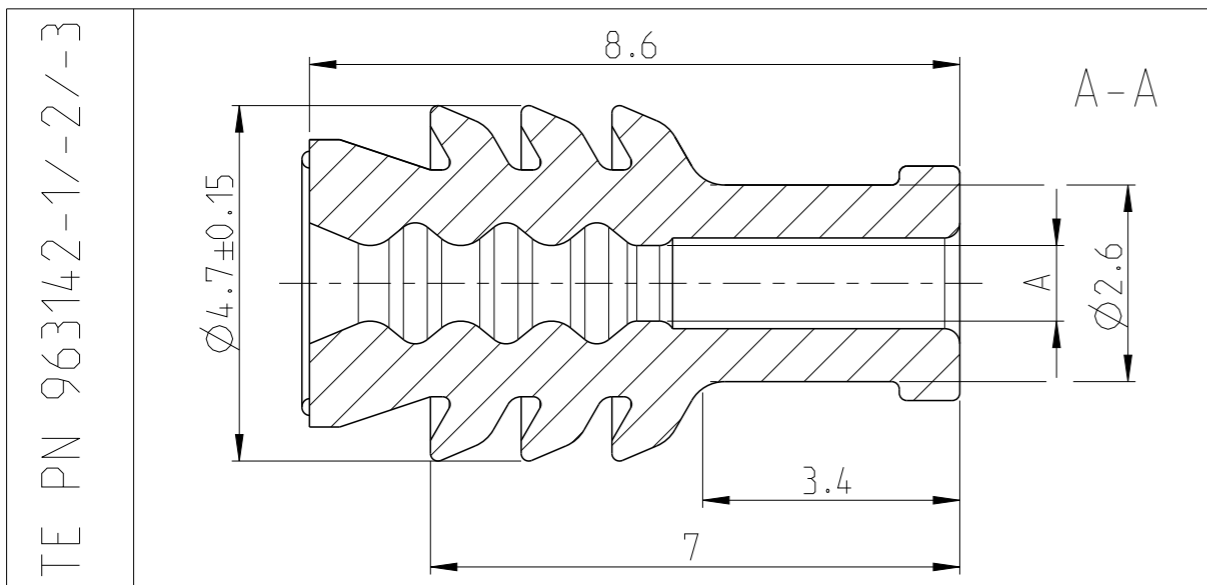

NOTES:

- 1 DETAILS OF DESIGN ARE LEFT TO MANUFACTURER
- 2 FOR ALLOCATION OF CONTACTS TO WIRE SIZE DIA AND RETAINING SINGLE WIRE SEAL. DRAWING OF CONTACT SYSTEMS SHALL BE BINDING
- 3 MOULD BURRS MAX 0.15mm PERMITTED

TE PN ORDER NO	REV.	DIM. A	SUITABLE TO INSULATION DIA.	USED ON	COLOR	MATERIAL	OIL %	WEIGHT [g]
963142-4	C	$\phi 1.5 \pm 0.15$	$\phi 2.2 \div 2.4$	Einzelleitung SINGLE WIRE	RED	Silikon VMQ 50	1.5% $\div$ 2%	0.09
963142-3	C	$\phi 1 \pm 0.15$	$\phi 1.4 \div 2.4$		blau/ LIGHT BLUE		4%	0.10
963142-2	C	$\phi 0.6 \pm 0.15$	$\phi 0.9 \div 1.3$		grau/GREY		1.5 $\div$ 2%	0.11
963142-1	C	$\phi 1 \pm 0.15$	$\phi 1.4 \div 2.4$		schwarz/BLACK			0.10

THIS DRAWING IS A CONTROLLED DOCUMENT.

DWN	S. G.	30OCT2008
CHK	C. Boemmel	30OCT2008
APVD	R. Jetter	30OCT2008
PRODUCT SPEC	-	-
APPLICATION SPEC	-	-
WEIGHT	-	-

**STE** TE Connectivity

NAME: SINGLE WIRE SEAL FOR CAVITY DIA. 4.0

SIZE	CAGE CODE	DRAWING NO	RESTRICTED TO
A3	00779	C=963142	

RESTRICTED CUSTOMER

SCALE: 10:1 SHEET: 1 OF 1 REV: C2