

Integrated PMIC with 4-Channel Synchronous Buck Converters, 8 LDOs, and MTP Non-Volatile Memory for Industrial Applications

General Description

The RT5028D is a highly-integrated low-power high-performance analog SOC with PMIC in one single chip designed for Industrial applications.

The RT5028D includes four synchronous step-down DC-DC converters and eight LDOs for system power.

The RT5028D also embeds one EEPROM (MTP) for setting sequence and timing etc.

Additionally, the RT5028D PMIC also includes one IRQ report.

Ordering Information

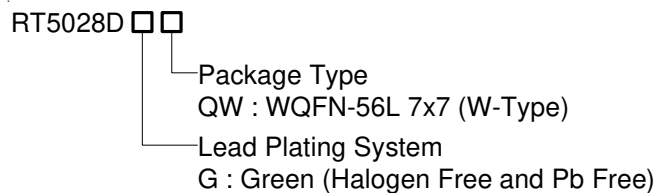

Note :

Richtek products are :

- ▶ RoHS compliant and compatible with the current requirements of IPC/JEDEC J-STD-020.
- ▶ Suitable for use in SnPb or Pb-free soldering processes.

Features

- Input Voltage Operating Range is 3.3V to 5.5V
- Step-Down Regulator : V_{IN} Range is 3.3V to 5.5V
 - ▶ Max Current 2.4A/2A/1.6A/2A
 - ▶ Programmable Frequency from 500kHz to 2MHz
 - ▶ I²C Programmable Output Level
 - ▶ I²C Programmable Operation Mode (Force PWM or Auto PSM/PWM)
 - ▶ I²C Programmable Output Discharge Mode (Discharge or Flatting)
- Linear Regulators : V_{IN} Range is 2.5V to 5.5V
 - ▶ Max Current 0.3A
 - ▶ I²C Programmable Output Level
- Embedded 32Bytes MTP for Factory Tuning
 - ▶ External MTP Pin for Write Protection
- Sequence can be Controlled by I²C or each EN pins Defined by MASK_GPIO pin.
- OT/UVP/VIN LV/POWRON press Time Interrupt (IRQ).
 - ▶ I²C Control Interface: Support Fast Mode up to 400kb/s
- RoHS Compliant and Halogen Free

Applications

- Industrial

Simplified Application Circuit

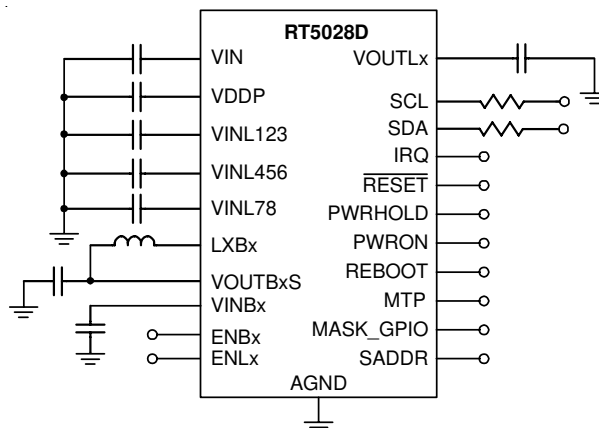

Marking Information



RT5028DGQW : Product Number

YMDNN : Date Code

Pin Configuration

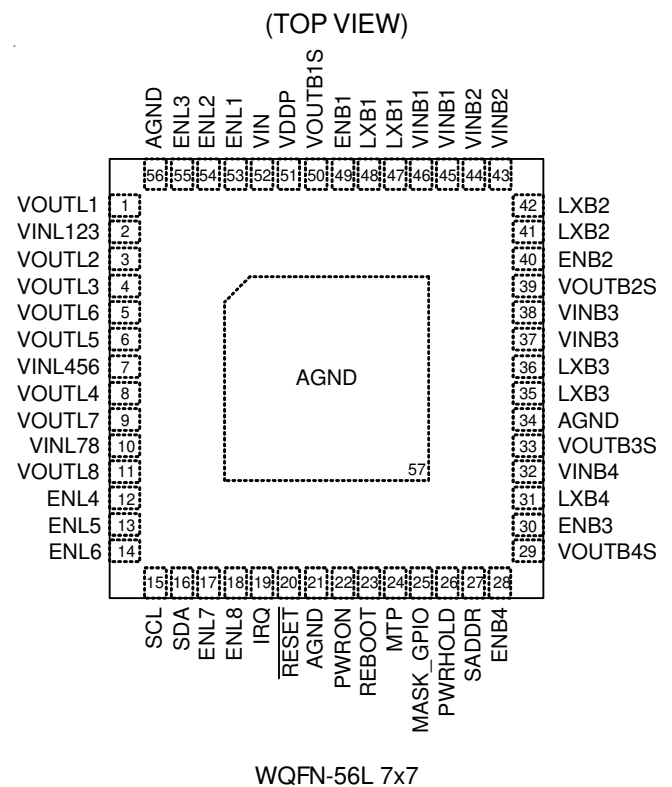

Functional Pin Description

Pin No.	Pin Name	Pin Function
1	VOUTL1	Output voltage regulation node for LDO1.
2	VINL123	Input power for LDO1, LDO2 and LDO3.
3	VOUTL2	Output voltage regulation node for LDO2.
4	VOUTL3	Output voltage regulation node for LDO3.
5	VOUTL6	Output voltage regulation node for LDO6.
6	VOUTL5	Output voltage regulation node for LDO5.
7	VINL456	Input power for LDO4, LDO5 and LDO6.
8	VOUTL4	Output voltage regulation node for LDO4.
9	VOUTL7	Output voltage regulation node for LDO7.
10	VINL78	Input power for LDO7 and LDO8.
11	VOUTL8	Output voltage regulation node for LDO8.
12	ENL4	Enable control input for LDO4. Connect a 100kΩ pull-low resistor.
13	ENL5	Enable control input for LDO5. Connect a 100kΩ pull-low resistor.
14	ENL6	Enable control input or LDO6. Connect a 100kΩ pull-low resistor.
15	SCL	Clock input for I ² C. Open-drain output, connect a 10kΩ pull-up resistor.

Pin No.	Pin Name	Pin Function
16	SDA	Data input for I ² C. Open-drain output, connect a 10kΩ pull-up resistor.
17	ENL7	Enable control input for LDO7. Connect a 100kΩ pull-low resistor.
18	ENL8	Enable control input for LDO8. Connect a 100kΩ pull-low resistor.
19	IRQ	Open-drain IRQ output node.
20	$\overline{\text{RESET}}$	Reset output.
21, 34, 56, 57 (Exposed Pad)	AGND	Analog ground. The exposed pad must be soldered to a large PCB and connected to AGND for maximum power dissipation.
22	PWRON	Manual power on. Connect a 100kΩ pull-up resistor.
23	REBOOT	System power reboot. Connect a 100kΩ pull-low resistor.
24	MTP	MTP write protection pin. Connect a 100kΩ pull-low resistor, logic low is inhibited and logic high is permit to write.
25	MASK_GPIO	Select I ² C or use EN pin for Bucks and LDOs. Connect a 100kΩ pull-low resistor. As MASK_GPIO is high, ignore all EN pins. As MASK_GPIO is low, EN pins and I ² C both can control. EN pins priority is higher than I ² C.
26	PWRHOLD	Power hold input. Connect a 100kΩ pull-low resistor.
27	SADDR	I ² C slave address. Connect a 100kΩ pull-low resistor.
28	ENB4	Enable control input for Buck4. Connect a 100kΩ pull-low resistor.
29	VOUTB4S	Output voltage regulation node for Buck4.
30	ENB3	Enable control input for Buck3. Connect a 100kΩ pull-low resistor.
31	LXB4	Internal switch node to output inductor connection for Buck4.
32	VINB4	Input power for Buck4.
33	VOUTB3S	Output voltage regulation node for Buck3.
35, 36	LXB3	Internal switch node to output inductor connection for Buck3.
37, 38	VINB3	Input power for Buck3.
39	VOUTB2S	Output voltage regulation node for Buck2.
40	ENB2	Enable control input for Buck2. Connect a 100kΩ pull-low resistor.
41, 42	LXB2	Internal switch node to output inductor connection for Buck2.
43, 44	VINB2	Input power for Buck2.
45, 46	VINB1	Input power for Buck1.
47, 48	LXB1	Internal switch node to output inductor connection for Buck1.
49	ENB1	Enable control input for Buck1. Connect a 100kΩ pull-low resistor.
50	VOUTB1S	Output voltage regulation node for Buck1
51	VDDP	Internal bias regulator voltage. External load on this pin is not allowed.
52	VIN	Input power for analog base.
53	ENL1	Enable control input for LDO1. Connect a 100kΩ pull-low resistor.
54	ENL2	Enable control input for LDO2. Connect a 100kΩ pull-low resistor.
55	ENL3	Enable control input for LDO3. Connect a 100kΩ pull-low resistor.

Functional Block Diagram

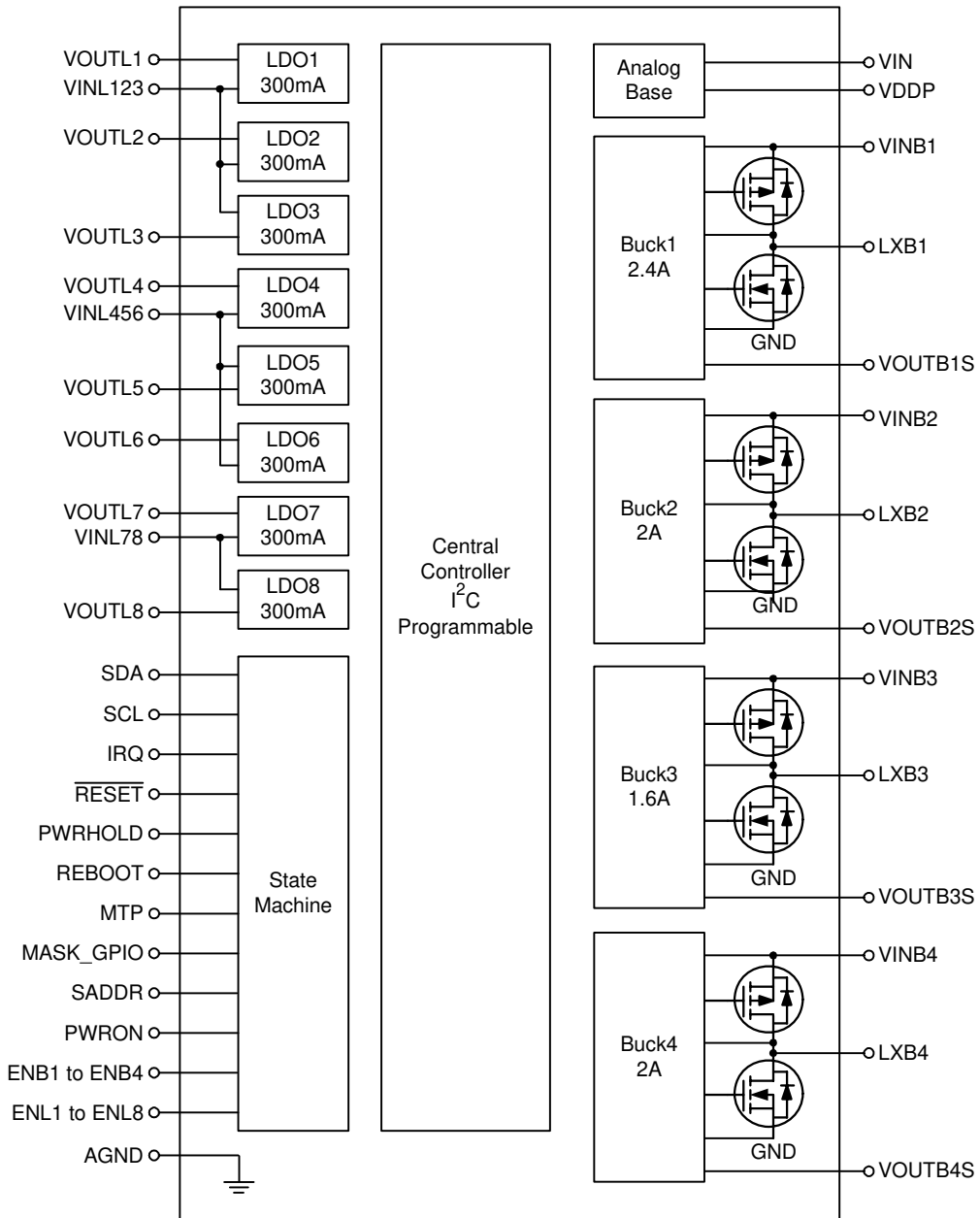

Operation

The RT5028D is a highly-integrated solution for industrial system including 4-CH step-down DC-DC converters and 8-CH LDOs. The RT5028D application mechanism will be introduced in later sections.

The power-on and power-off sequences can be controlled by I²C or each EN pin and detected in MASK_GPIO pin. When the MASK_GPIO pin is at Hi level, the PMIC follows the power-on sequence to turn on channels. When the MASK_GPIO pin is at Lo level, the channels of PMIC will be controlled by the EN pin.

Synchronous Step-Down DC-DC Converter

Four current mode synchronous step-down DC-DC converters operate with internal power MOSFETs, FB resistors and compensation network. These channels are suitable for core power in industrial system. They can be operated at 100% maximum duty cycle to extend battery operating voltage range. When the input voltage is close to the output voltage, the converter enters low dropout mode with low output ripple. The operating frequency of step-down converter is adjustable from 500kHz to 2MHz and is controlled by I²C. Besides, the I²C interface also can be used to select different operation modes, On/Off Sequence, programmable the output voltage, RAMP control and discharge function. To enable AUTO Mode, it is used to improve the efficiency at light load. If the AUTO Mode is disabled, the converter operates in force PWM mode with fixed switching frequency.

Linear Regulator

Eight generic low voltage LDOs for multiple purpose power. The LDOs are stable over the entire operating load range with the use of external ceramic capacitors. The LDOs also have I²C programmable power on/off sequence and discharge function. The output voltage is adjustable by the I²C interface in the range of 1.6V to 3.6V.

Over-Temperature Protection

An Over-Temperature Protection (OTP) is contained in the device. The protection is triggered to force the device shutdown for protecting itself when the junction temperature exceeds 165°C typically. Once the junction temperature drops below the hysteresis 10°C typically, the device must be re-send PWRON to start system.

Output Under-Voltage Protection

The output under-voltage protection is implemented in order to prevent operation at low output voltage conditions. When the step-down DC-DC converters output voltage is lower than 1/2 x (V_{OUT}), the UVP event triggers and PMIC turns off immediately.

Absolute Maximum Ratings (Note 1)

- Analog Base Input Voltage, VIN ----- -0.3V to 6V
- PMIC Input Voltage, VINL123/456/78, VINB1/2/3/4 ----- -0.3V to 6V
- PMIC Output Voltage, VOUTLx, VOUTBxS, LXBx ----- -0.3V to 6V
- PMIC related Other Pins ----- -0.3V to 6V
- Power Dissipation, P_D @ $T_A = 25^\circ\text{C}$
 WQFN-56L 7x7 ----- 3.7W
- Package Thermal Resistance (Note 2)
 WQFN-56L 7x7, θ_{JA} ----- 27°C/W
 WQFN-56L 7x7, θ_{JC} ----- 7°C/W
- Junction Temperature ----- 150°C
- Lead Temperature (Soldering, 10 sec.) ----- 260°C
- Storage Temperature Range ----- -65°C to 150°C
- ESD Susceptibility (Note 3)
 HBM (Human Body Model) ----- 2kV
 MM (Machine Model) ----- 200V

Recommended Operating Conditions (Note 4)

- Junction Temperature Range ----- -40°C to 125°C
- Ambient Temperature Range ----- -40°C to 85°C

Electrical Characteristics

(VIN = 3.3V to 5.5V, TA = -40°C to 85°C, unless otherwise specified)

Parameter	Symbol	Test Conditions	Min	Typ	Max	Unit
Operation Voltage of VIN		As $f_{SW} > 1\text{MHz}$, $3.3\text{V} \leq V_{IN} \leq 5.5\text{V}$. If $f_{SW} \leq 1\text{MHz}$, $V_{IN} \geq 4\text{V}$.	3.3	--	5.5	V
PMIC						
Quiescent Current	I _{IN}	V _{IN} = 5V, LDOs, Bucks are ON with no load.	300	450	600	μA
		V _{IN} = 5V, LDOs, Bucks are OFF. SCL = SDA = 0V	5	20	40	μA
Warning for Die Temperature	OTW	Temperature 1	--	100	--	°C
		Temperature 2	--	125	--	
Over-Temperature Protection	OTP		--	165	--	°C
OTP and Warning Hysteresis			--	10	--	°C
Input Pull-low 100k Resistor	R _{Low}	V _{IN} = 5V, Temperature = -40°C to 125°C	70	115	160	kΩ

Parameter	Symbol	Test Conditions	Min	Typ	Max	Unit	
Buck1 to Buck4							
Input Voltage	V _{INB}		3.3	--	5.5	V	
Output Voltage	V _{OUTB}	Buck1 I ² C programmable per step 25mV	0.7	--	1.8	V	
		Buck2 I ² C programmable per step 25mV	0.7	--	1.8		
		Buck3 I ² C programmable per step 50mV	0.7	--	3.6		
		Buck4 I ² C programmable per step 50mV	0.7	--	3.6		
Consumption Current	I _{VINB}	AUTO Mode I _{OUT} = 0mA, Each Buck	10	20	40	μA	
Efficiency Peak	Eff	V _{OUT} = 1.2V, V _{IN} = 3.6V	I _{LOAD} = CCM	--	88	--	%
			I _{LOAD} = 1mA	--	80	--	
Output Voltage Accuracy	V _{OUTAcc}	3.1V < V _{IN} < 5.5V, 1mA < I _{OUT} < I _{MAX}	As V _{OUTB1S} to V _{OUTB4S} ≥ 1V.	-3	--	3	%mV
			As V _{OUTB1S} to V _{OUTB4S} < 1V.	30	--	30	
Output Voltage Ripple	V _{Rip}	I _{OUT} = 1mA, C _{OUT} = 10μF, 2MHz		--	25	--	mV
		I _{OUT} = 1A, C _{OUT} = 10μF, 2MHz		--	8	--	
Output Voltage Temperature Coefficient			--	±100	--	ppm/°C	
Switching Frequency	f _{sw}	I ² C programmable	0.43	--	2	MHz	
Switching Frequency Accuracy		1MHz < f _{sw}	-10	--	10	%	
		f _{sw} ≤ 1MHz	-20	--	20		
Suggest Inductor	L _{Buck}		--	2.2	--	μH	
Peak Current Limit	OCP	Buck1	3.1	4.4	5.8	A	
		Buck2	2.8	4	5.2		
		Buck3	2.6	3.7	4.8		
		Buck4	2.8	4.1	5.3		
Under-Voltage Protection	UVP	V _{OUTB1S} to V _{OUTB4S} < 0.66 x (V _{OUT} Target)	56	66	76	%	
Maximum Output Current	I _{MAX}	Buck1	2.4	--	--	A	
		Buck2	2	--	--		
		Buck3	1.6	--	--		
		Buck4	2.0	--	--		
Output Transient Response	V _{peak}	0.8A to 1.6A at 20μs, V _{OUT} = 1.2V Buck1 and Buck2	-4	--	4	%	
High-Side On-Resistance	R _{pon}	V _{IN} = 3.7V	50	150	250	mΩ	
Low-Side On-Resistance	R _{nnon}	V _{IN} = 3.7V	40	110	160	mΩ	

Parameter	Symbol	Test Conditions	Min	Typ	Max	Unit	
LDO1 to LDO8							
Input Voltage for VINL123/456/78	V _{INL}		2.5	--	5.5	V	
Output Voltage LDO123/78	V _{OUTL}	3.1V ≤ V _{IN} ≤ 5.5V, 50μA ≤ I _{OUT} ≤ I _{MAX}	-3%	1.6 to 3.6	3%	V	
Output Voltage LDO456	V _{OUTL}	3.1V ≤ V _{IN} ≤ 5.5V, 50μA ≤ I _{OUT} ≤ I _{MAX}	-3%	3 to 3.6	3%	V	
Output Current	I _{OUT}		300	--	--	mA	
Output Short Current	I _{sht}		330	450	600	mA	
Voltage Difference	V _{IN} - V _{OUT}	V _{IN} > 3.1V	V _{IN} = V _{SET} , I _{OUT} = I _{OUTMAX}	0.05	0.1	0.3	V
		V _{IN} > 2.5V		0.05	0.11	0.5	
Output Voltage Temperature Coefficient			--	±100	--	ppm/°C	
Supply Current	I _{SS}	I _{OUT} = 0mA	10	35	60	μA	
Shutdown Current	I _{OFF}		0	1	2	μA	
Line Regulation		Input 3V to 5V, load = 100mA	0	1	5	mV	
Load Regulation		V _{IN} = 5V, Load 100mA to 300mA	0	0.1	1	%	
Transient Response	ΔV _{OUT}	50μA ↔ I _{OUTMAX} / 2 (Δt = 1μs)	--	50	--	mV	
Ripple Rejection		f = 10kHz, I _{OUT} = I _{OUTMAX} / 2	--	60	--	dB	
Rising Time		V _{OUT} ≥ 0.7 × V _{Target} , I _{OUT} = 0mA	150	220	300	μs	
Falling Time		V _{OUT} ≤ 0.3 × V _{Target} , I _{OUT} = 0mA	300	600	1000	μs	
I²C Interface and Control Input Pin Electrical Characteristics							
Voltage Output Low	V _{OL}		--	--	0.4	V	
Input Voltage	High-Level	V _{IH}	1.5	--	--	V	
	Low-Level	V _{IL}	--	--	0.4		
SCL Clock	SCL		--	--	400	kHz	

Note 1. Stresses beyond those listed “Absolute Maximum Ratings” may cause permanent damage to the device. These are stress ratings only, and functional operation of the device at these or any other conditions beyond those indicated in the operational sections of the specifications is not implied. Exposure to absolute maximum rating conditions may affect device reliability.

Note 2. θ_{JA} is measured at T_A = 25°C on a high effective thermal conductivity four-layer test board per JEDEC 51-7. θ_{JC} is measured at the exposed pad of the package.

Note 3. Devices are ESD sensitive. Handling precaution is recommended.

Note 4. The device is not guaranteed to function outside its operating conditions.

Typical Application Circuit

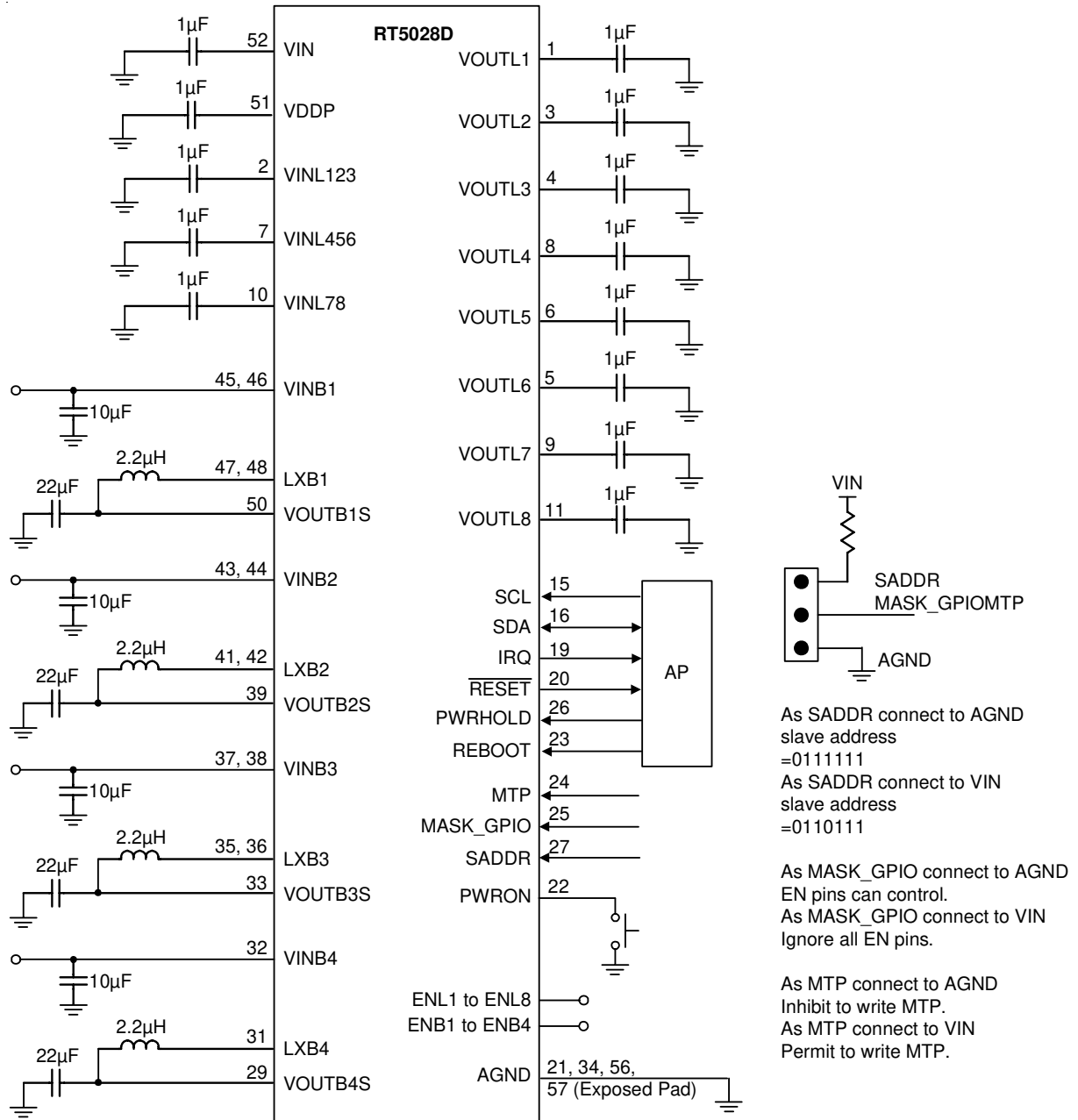

Typical Operating Characteristics

CH1 Buck Efficiency vs. Output Current

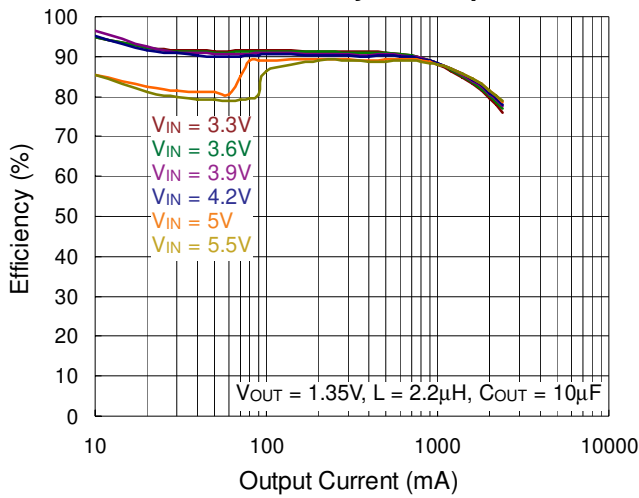

CH2 Buck Efficiency vs. Output Current

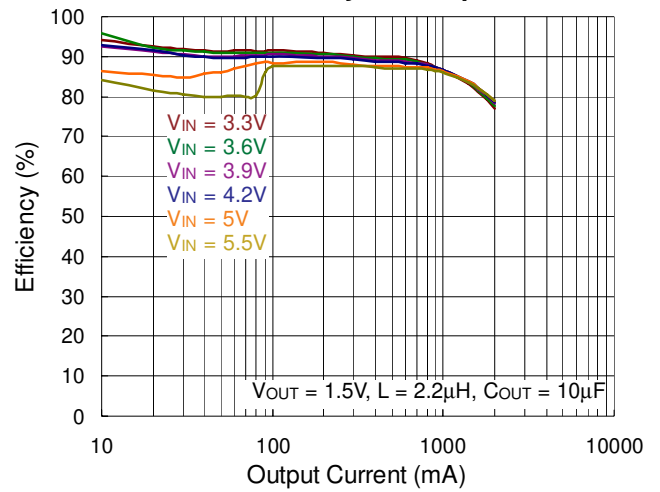

CH3 Buck Efficiency vs. Output Current

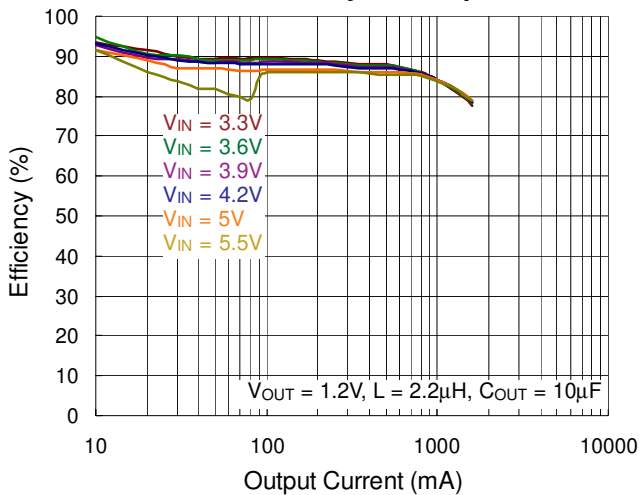

CH4 Buck Efficiency vs. Output Current

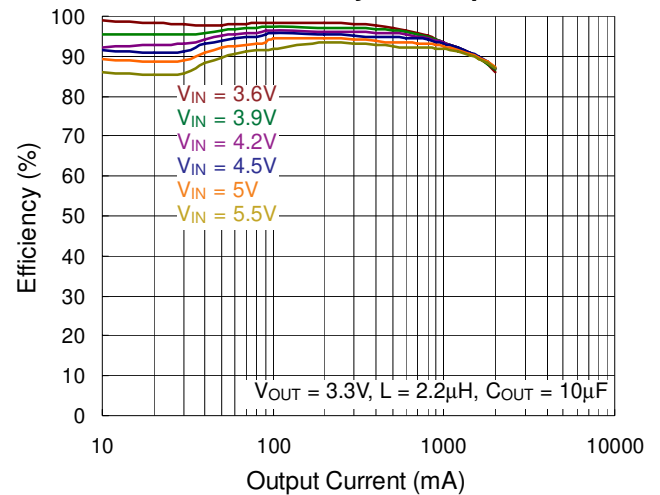

CH1 Buck Output Voltage vs. Output Current

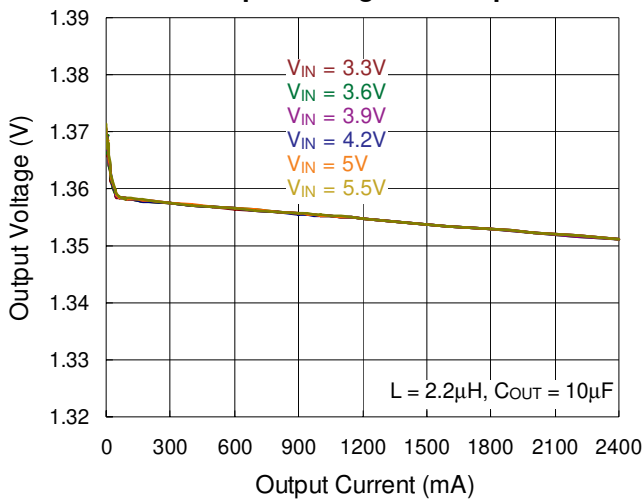

CH2 Buck Output Voltage vs. Output Current

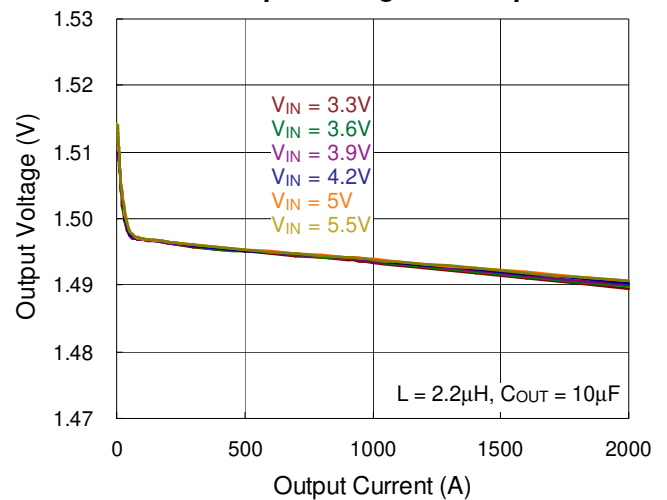

CH3 Buck Output Voltage vs. Output Current

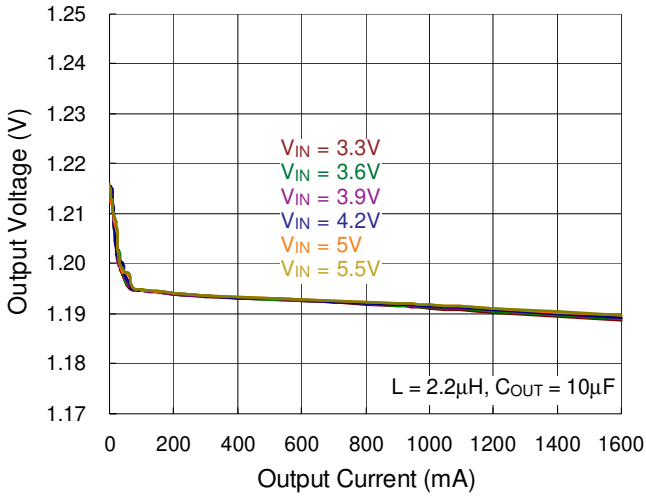

CH4 Buck Output Voltage vs. Output Current

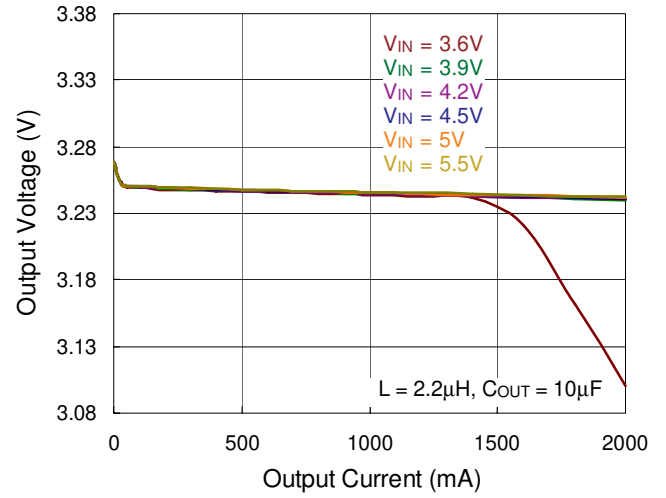

CH1 Buck Output Voltage vs. Input Voltage

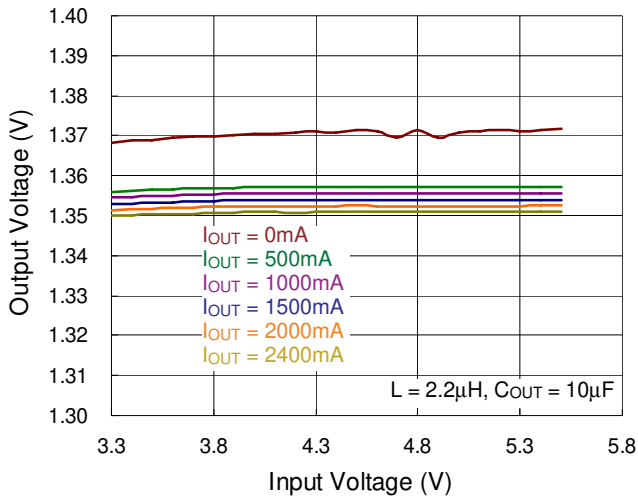

CH2 Buck Output Voltage vs. Input Voltage

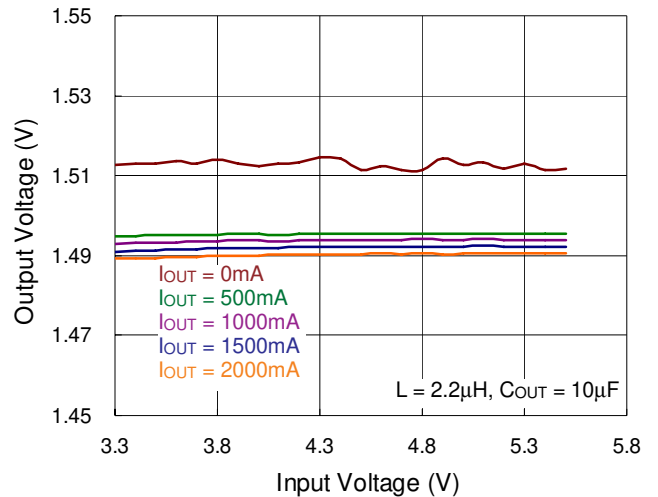

CH3 Buck Output Voltage vs. Input Voltage

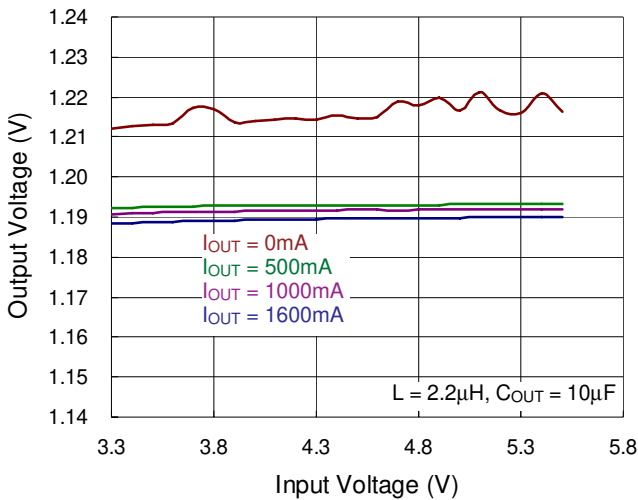

CH4 Buck Output Voltage vs. Input Voltage

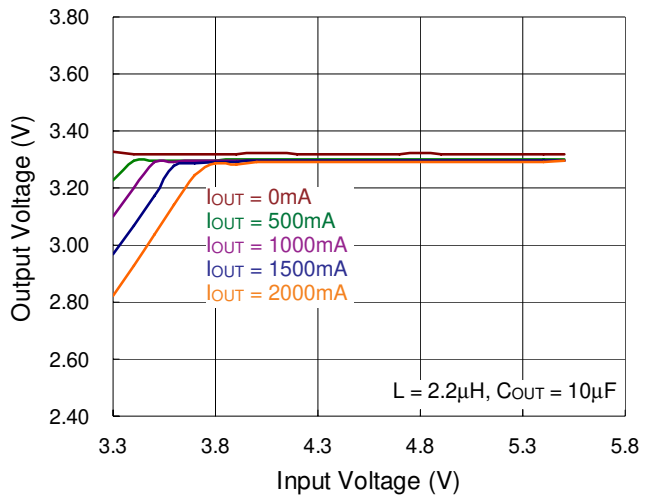

LDO2 Output Voltage vs. Output Current

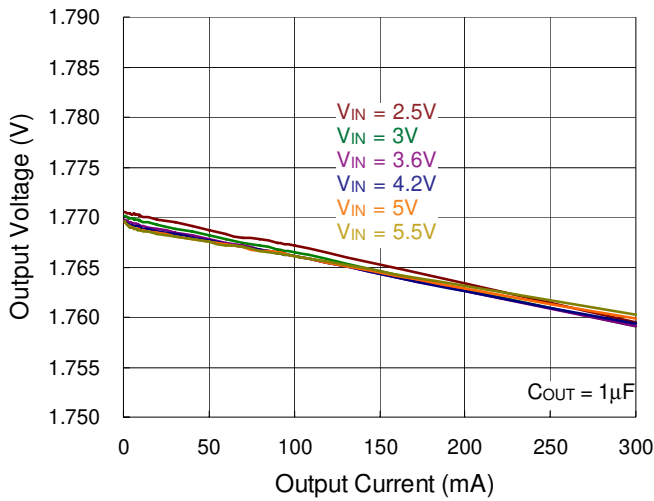

LDO5 Output Voltage vs. Output Current

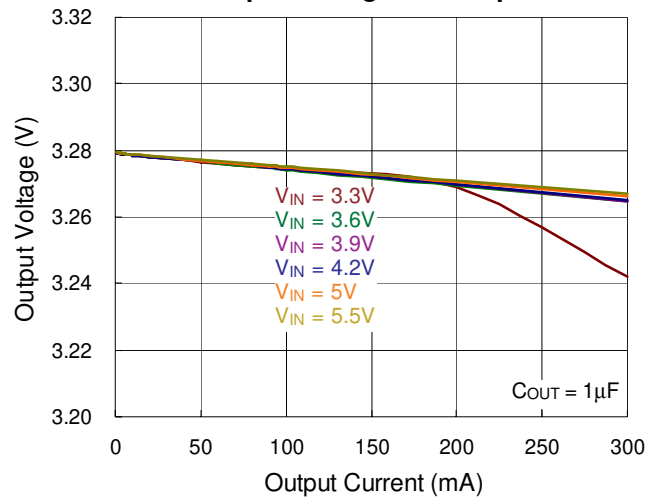

LDO7 Output Voltage vs. Output Current

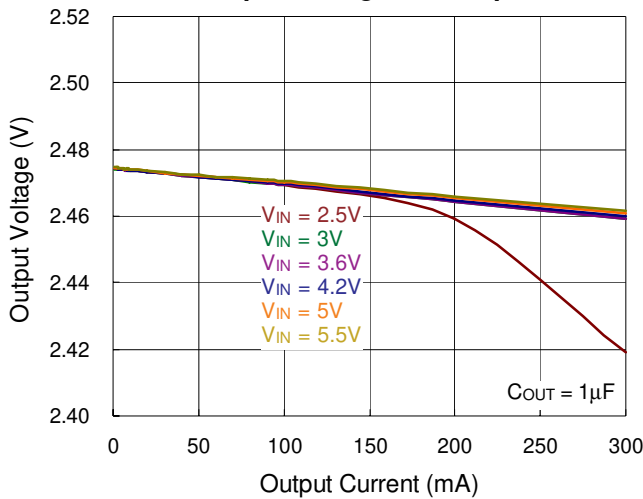

LDO2 Output Voltage vs. Input Voltage

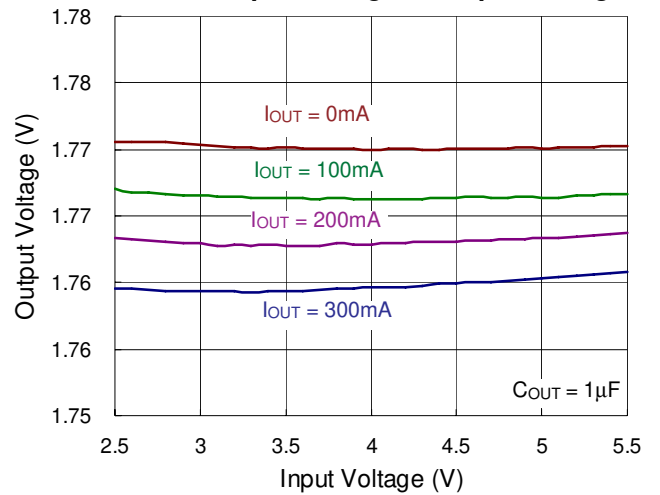

LDO5 Output Voltage vs. Input Voltage

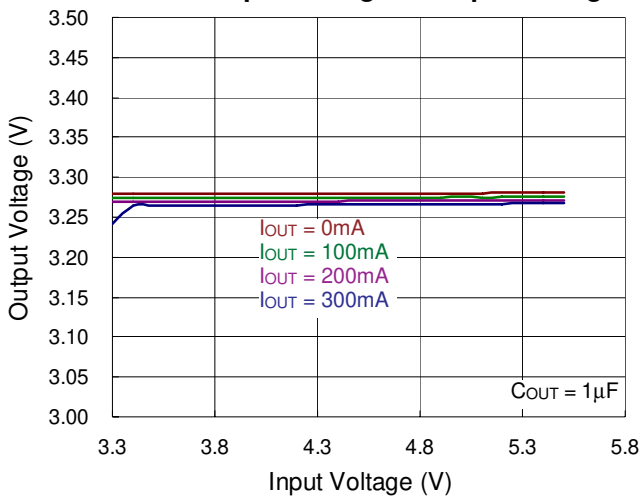

LDO7 Output Voltage vs. Input Voltage

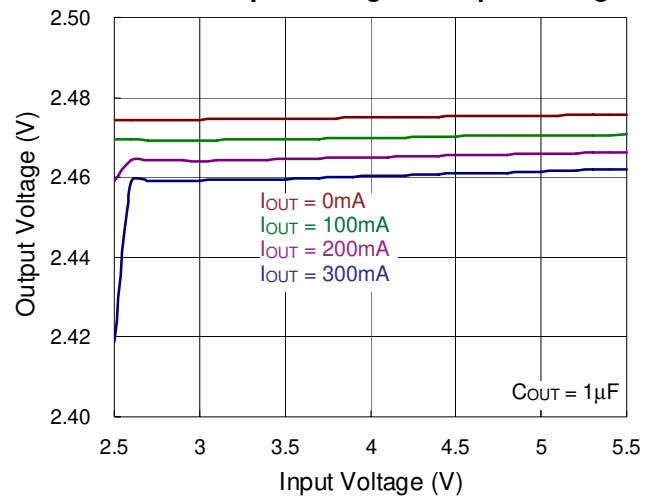

Application Information

The RT5028D is a highly-integrated solution for industrial system including PMIC and memory system. The RT5028D application mechanism and I²C compatible interface are introduced in later sections. The system's slave address is 0110111 (As SADDR = high) or 0111111 (As SADDR = low).

PMIC - Power management system provides 8 low dropout linear regulator and 4 high efficiency synchronous step-down DC-DC converters. Power-On and Power-Off sequences are control by PWRON and $\overline{\text{RESET}}$ input pins.

Detail time sequence control is described in Power ON/OFF diagram. The I²C interface can program individual regulator output voltage as well as on/off control and voltage setting.

I²C Interface Timing Diagram

The RT5028D acts as an I²C -bus slave. The I²C-bus master configures the settings for all function blocks by sending command bytes to the RT5028D via the 2-wire I²C-bus. The I²C timing diagrams are list in the following.

Read Function

Reading One Indexed Byte of Data from RT (With 1-Byte)

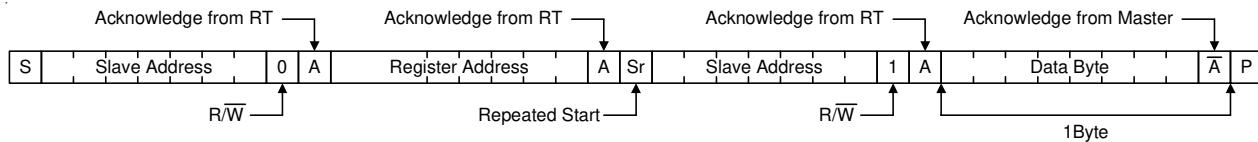

Reading n Indexed Words of Data from RT (With N-Byte)

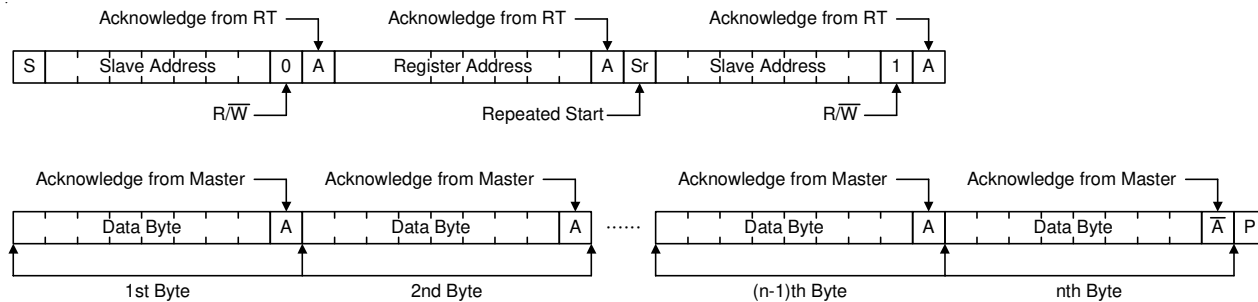

Write Function

Writing One Byte of Data to RT (With 1-Byte)

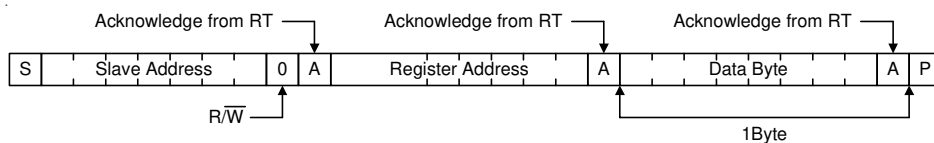

Writing n Bytes of Data to RT (With N-Byte)

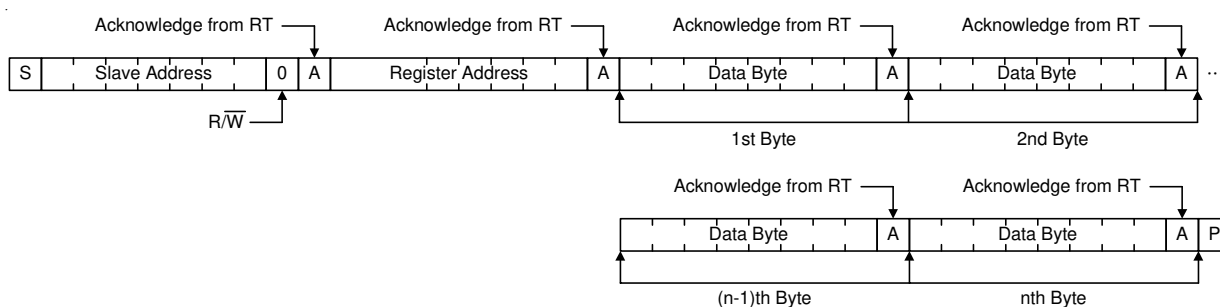

PMIC

Power Channels Control Methodology

When VIN power Good or PWRON event occurs, the PMIC will follow the power on sequence to turn on channels. During normal operation, users can use the REBOOT pin

to restart PMIC again. Another PWROFF event, OTP or UVP occurs, PMIC will execute the power off. In the RT5028D PMIC, the UVP event will be set out when the Buck1 to Buck4s' output voltage is lower than $1/2 \times (V_{OUT})$.

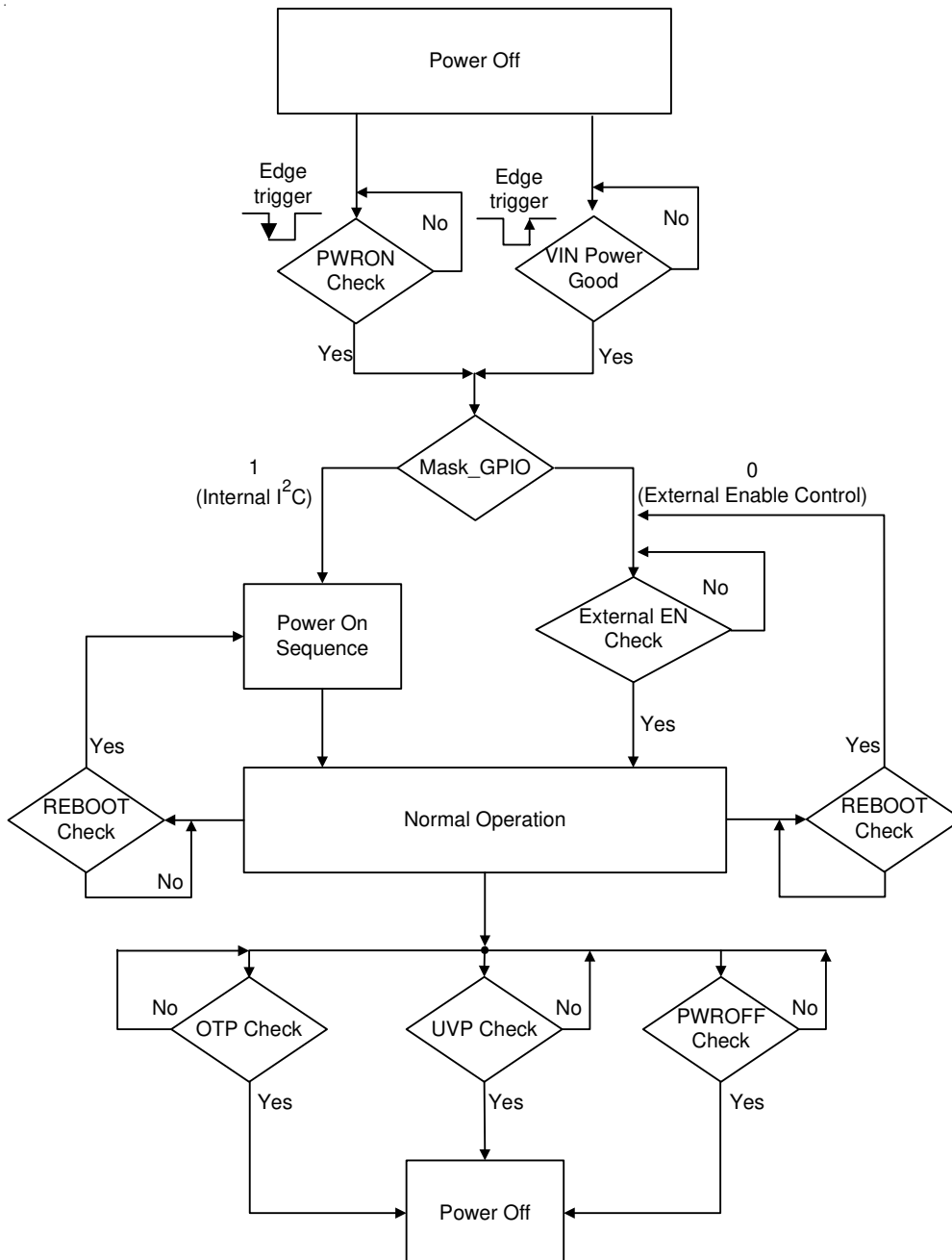

PMIC - POWER ON/OFF Setting

The circuit setting for communication between RT5028D and AP is showed as below.

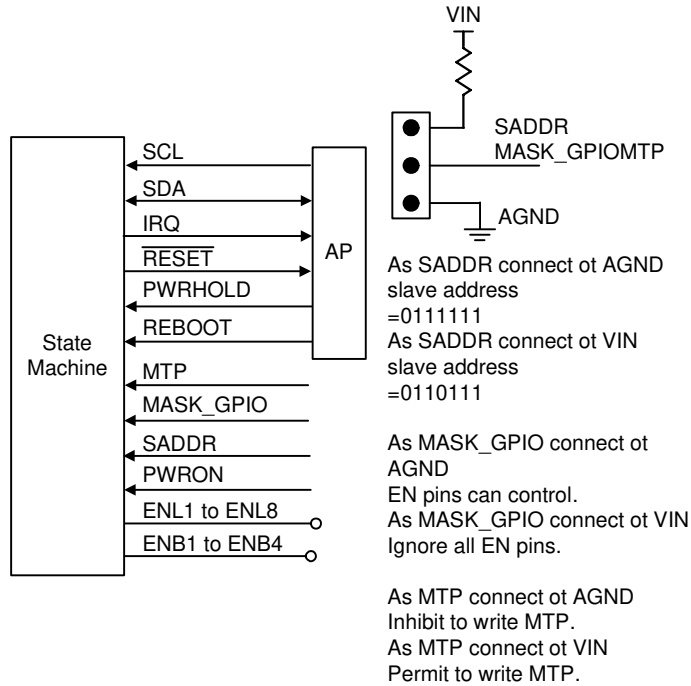

Power Hold Function

When the “PWRHOLD” signal does not come during THOLD time, the RT5028D will do shutdown sequence.

If users want to disable power hold function, set “DisTHOLD” bit in I²C register 10 bit[0] to disable this function. In the timing diagram below, the “THOLD” and “RESET_DLY” can be set by MTP program.

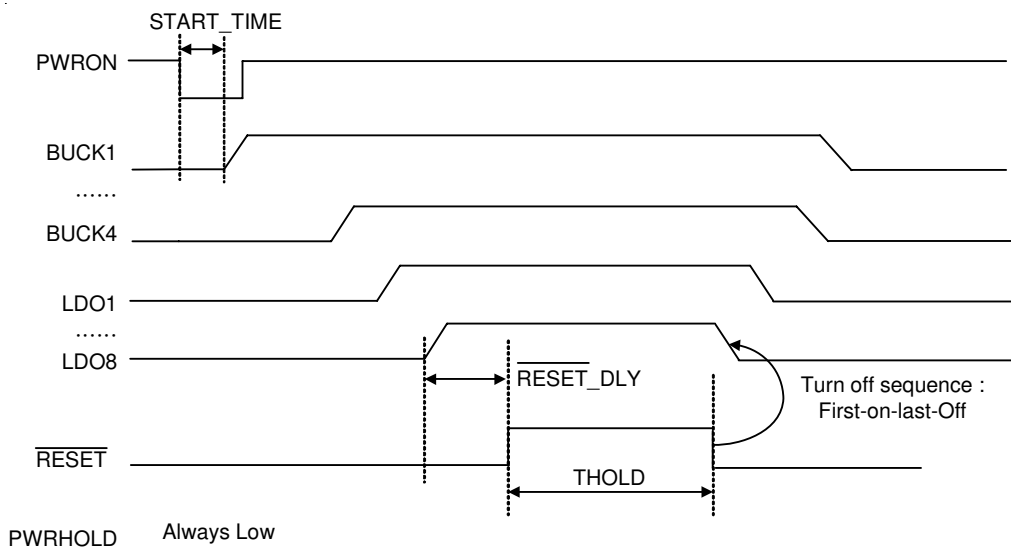

When AP sends the “PWRHOLD” signal during THOLD time, the RT5028D will keep power-on.

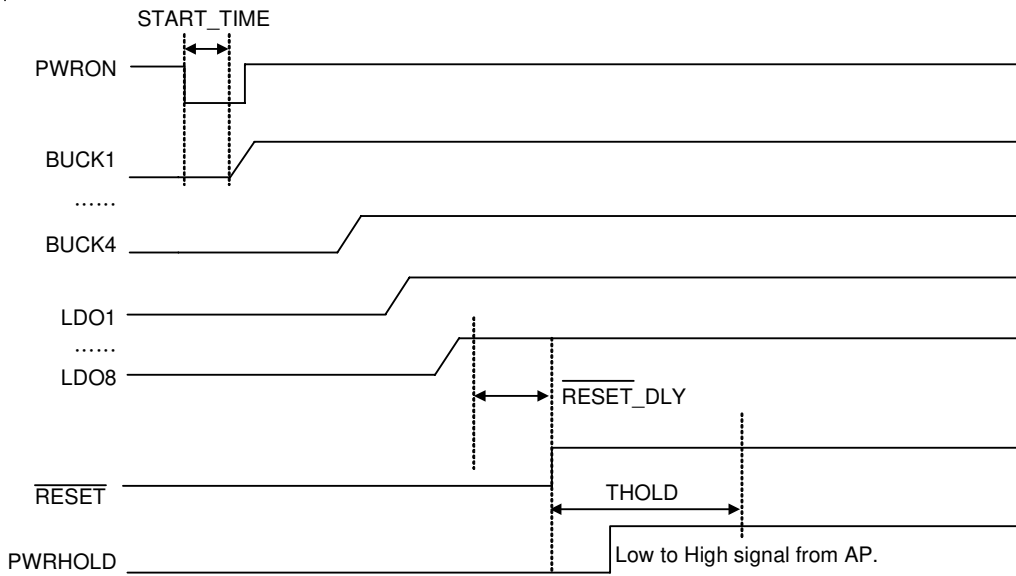

Timing Based ON/OFF Sequence

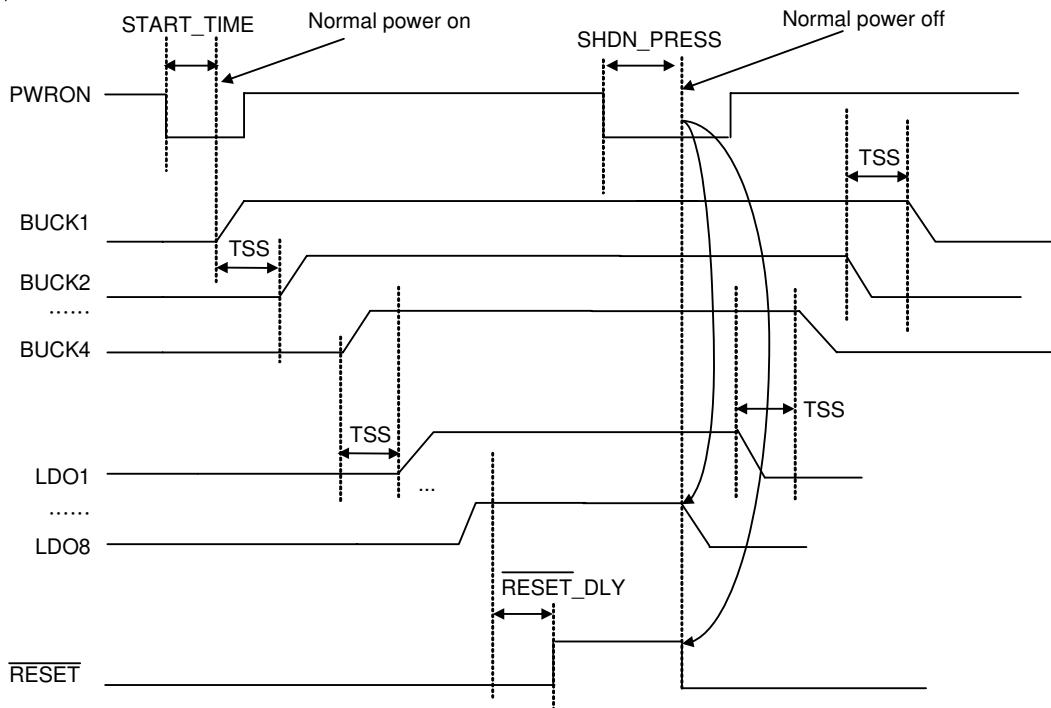

Level Based ON/OFF Sequence

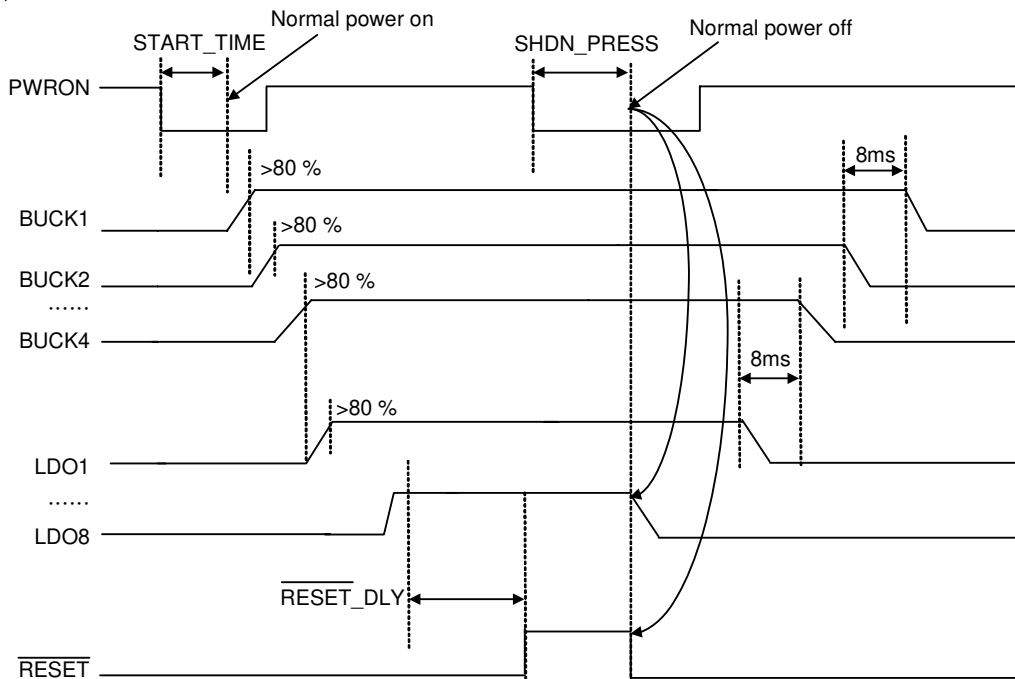

Abnormal OFF

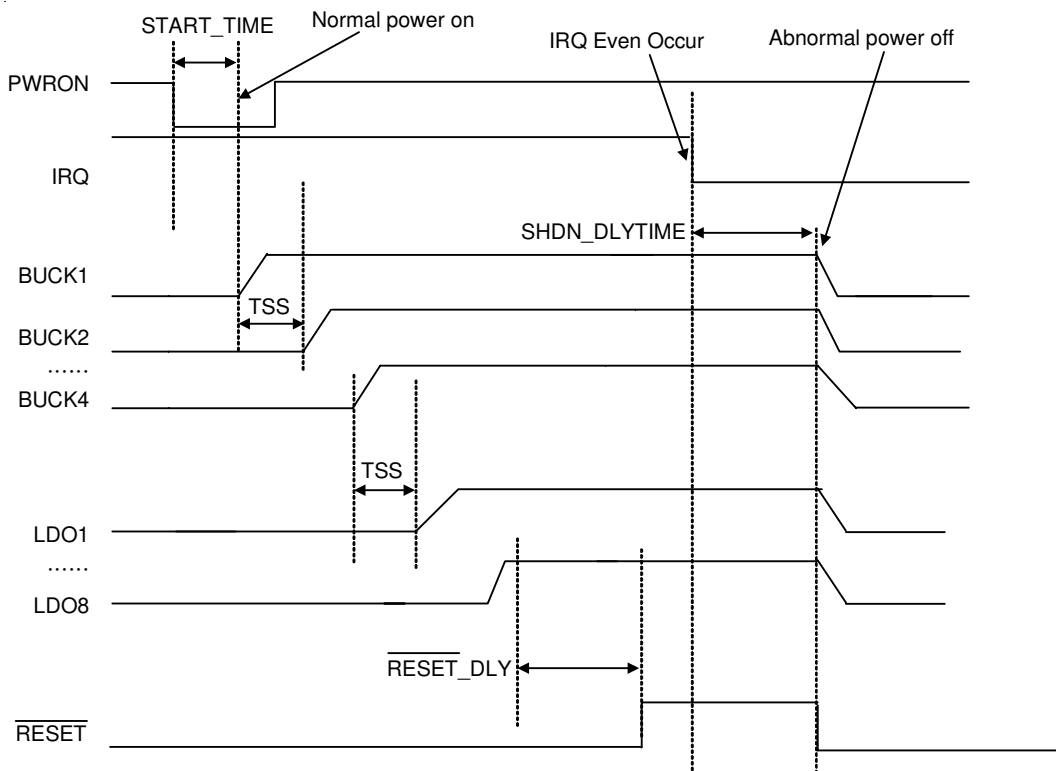

Based ON/OFF Sequence by VIN

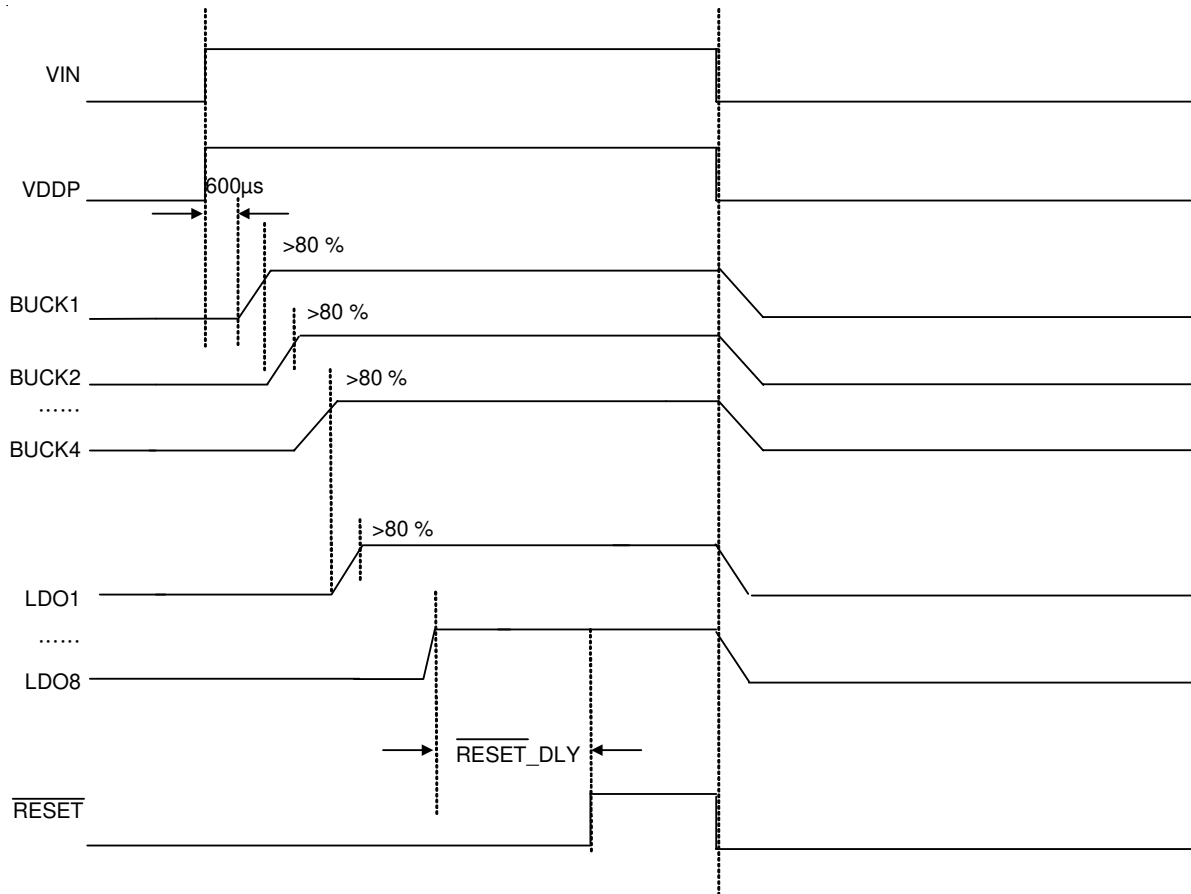

PMU On/Off Sequence Setting

In the RT5028D, users can set the power on/off sequence and output voltage by I²C register 0x01 to 0x04 for Buck output voltage, 0x07 to 0x0E for LDO output voltage and 0x2C to 0X32 for startup sequence setting.

In the table below, users must set one by one (continues number) and missing code is not allowed.

If users miss sequence code, the RT5028D will wait for next channel and the IC will be hold in waiting status.

	Output Voltage Setting	Startup Sequence Setting	Startup Enable Method (Soft-Start Control)
Buck1	Buck1Output[5:0]	Buck1_Seq[3:0]	[10]
	[000000]	[0001]	
Buck2	Buck2Output[5:0]	Buck2_Seq[3:0]	
	[101100]	[0010]	
Buck3	Buck3Output[5:0]	Buck3_Seq[3:0]	
	[000000]	[0011]	
Buck4	Buck4Output[5:0]	Buck4_Seq[3:0]	
	[101100]	[0100]	
LDO1	LDO1OUT[6:0]	LDO1_Seq[3:0]	
	[0000000]	[0101]	
LDO2	LDO2OUT[6:0]	LDO2_Seq[3:0]	
	[0101000]	[0110]	
LDO3	LDO3OUT[6:0]	LDO3_Seq[3:0]	
	[0000000]	[0111]	
LDO4	LDO4OUT[6:0]	LDO4_Seq[3:0]	
	[0101000]	[1000]	
LDO5	LDO5OUT[6:0]	LDO5_Seq[3:0]	
	[0000000]	[1001]	
LDO6	LDO6OUT[6:0]	LDO6_Seq[3:0]	
	[0101000]	[1010]	
LDO7	LDO7OUT[6:0]	LDO7_Seq[3:0]	
	[0000000]	[1011]	
LDO8	LDO8OUT[6:0]	LDO8_Seq[3:0]	
	[0101000]	[1100]	

Note :

* Output Voltage Setting: fill relative binary code to set the output voltage.

* Startup Sequence Setting :

“0000” denotes no operation (disable).

“0001” denotes first-startup.

“1100 to 1111” denotes last-startup.

If same number, it means startup at the same time.

*Startup Enable Method :

[01] to [11] : each startup enable interval time (1ms, 4ms, 8ms).

[00] : start end voltage (the output voltage's 80%)

Synchronous Step-Down DC-DC Converter

Four current mode synchronous step-down DC-DC converters operate with internal power MOSFETs and compensation network. These channels supply the power core chip of portable system. They can be operated at 100% maximum duty cycle to extend battery operating voltage range. When the input voltage is close to the output voltage, the converter enters low dropout mode with low output ripple. The operating frequency range of step-down converter is 0.5MHz to 2MHz.

Four step-down converters have RAMP control function as the following diagram.

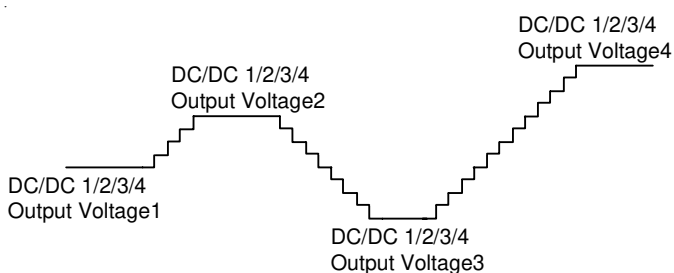

REBOOT Function

As the REBOOT pin is set from low to high, the REBOOT function will be active. The REBOOT's FSM is shown as below. It concludes 100ms de-bouncing time and delay1/delay2 power off delay time.

Table 1. REBOOT Input Control Setting

	Description	Default
delayed2	00 : 100ms 10 : 1s	10
delayed1	01 : 500ms 11 : 2s	10
Action	delayed1 power-off then delayed2 power-on PMIC	

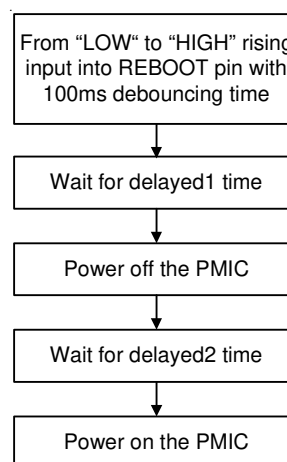

IRQ Table

We summarize all IRQ items in the register table. All IRQ_status registers are implemented as reset after read. If IRQ_enable bit is Low, the IRQ_status bit will not update status. IRQ_enable will mask IRQ_status to trigger IRQ_PMIC Low, so the system can decide which interrupt is necessary.

Waveform - (when the other IRQ_status are low)

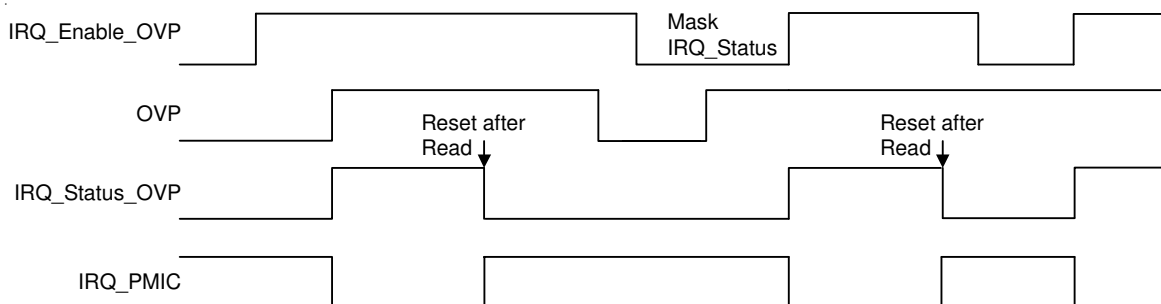

Waveform - (when the other IRQ_status are low)

* OTW125/OTW100 means the 125°C/100°C pre-warming over temperature. It only change IRQ status bits and don't trigger IRQ pin.

EEPROM (MTP) Control Flow

The RT5028D embeds 32 bytes MTP memory, and it allows users to save some I²C register bank data to MTP. When the I²C register 0x3A Bit[0]/Bit[1] is wrote to “1”, the MTP Page1/Page2 will execute erase process firstly.

Because the erase process will be done in every writing time, the MTP data will be missed. So it would be best for users to read data from MTP to I²C first before executing writing process.

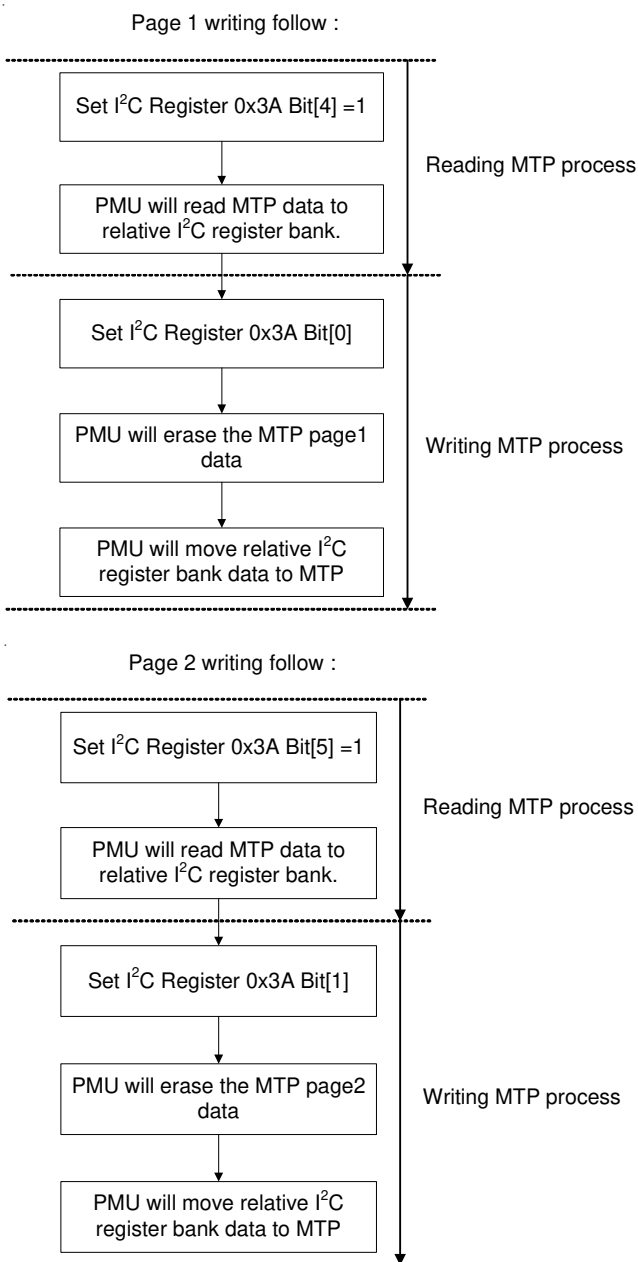

Thermal Considerations

For continuous operation, do not exceed absolute maximum junction temperature. The maximum power dissipation depends on the thermal resistance of the IC package, PCB layout, rate of surrounding airflow, and difference between junction and ambient temperature. The maximum power dissipation can be calculated by the following formula :

$$P_{D(MAX)} = (T_{J(MAX)} - T_A) / \theta_{JA}$$

where $T_{J(MAX)}$ is the maximum junction temperature, T_A is the ambient temperature, and θ_{JA} is the junction to ambient thermal resistance.

For recommended operating condition specifications, the maximum junction temperature is 125°C. The junction to ambient thermal resistance, θ_{JA} , is layout dependent. For WQFN-56L 7x7 package, the thermal resistance, θ_{JA} , is 27°C/W on a standard JEDEC 51-7 four-layer thermal test board. The maximum power dissipation at $T_A = 25^\circ\text{C}$ can be calculated by the following formula :

$$P_{D(MAX)} = (125^\circ\text{C} - 25^\circ\text{C}) / (27^\circ\text{C/W}) = 3.7\text{W for WQFN-56L 7x7 package}$$

The maximum power dissipation depends on the operating ambient temperature for fixed $T_{J(MAX)}$ and thermal resistance, θ_{JA} . The derating curve in Figure 1 allows the designer to see the effect of rising ambient temperature on the maximum power dissipation.

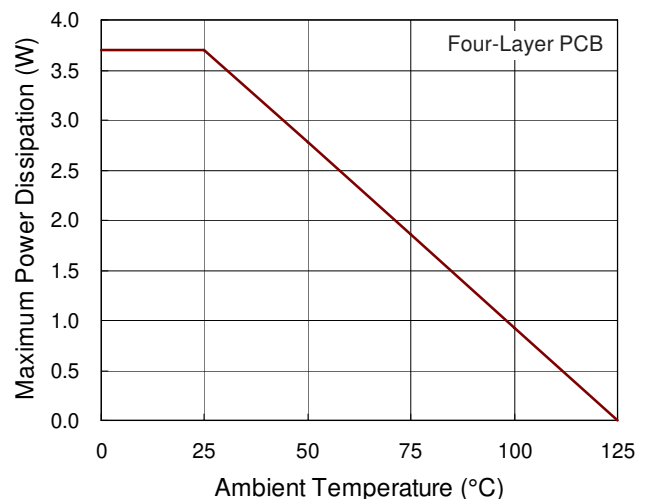

Figure 1. Derating Curve of Maximum Power Dissipation

Layout Consideration

For the best performance of the RT5028D, the following PCB layout guidelines must be strictly followed.

- ▶ Place the input and output capacitors as close as possible to the input and output pins respectively for good filtering.
- ▶ Keep the main power traces as wide and short as possible.
- ▶ The switching node area connected to LX and inductor should be minimized for lower EMI.
- ▶ Connect the GND and Exposed Pad to a strong ground plane for maximum thermal dissipation and noise protection.
- ▶ Directly connect the output capacitors to the feedback network of each channel to avoid bouncing caused by parasitic resistance and inductance from the PCB trace.

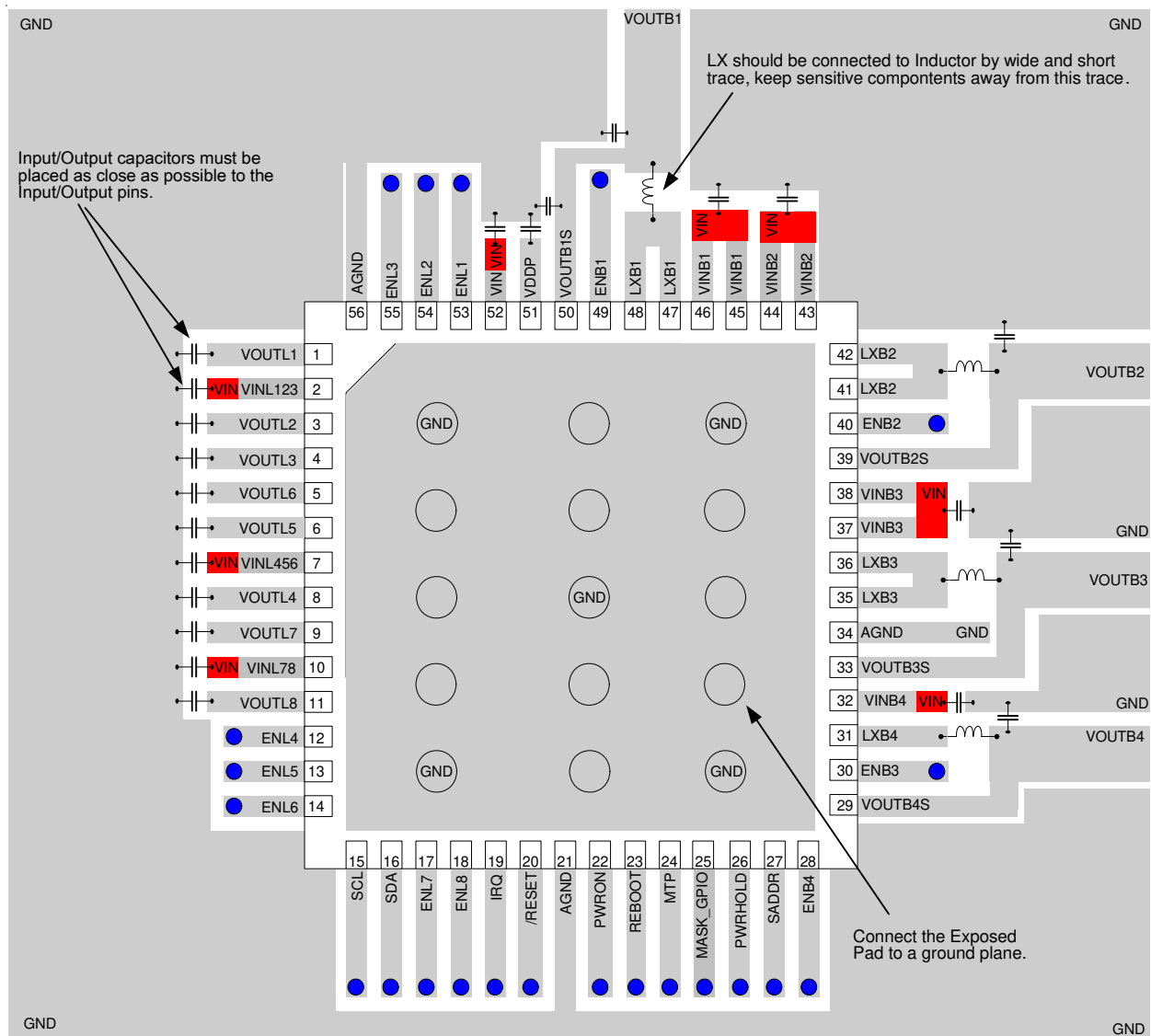

Figure 2. PCB Layout Guide

Table 2. I²C Register Table

Detail Description				
Address	00	Device ID		
Bit	Name	Description	Read/Write	Reset Value
[7:4]	VENDOR_ID	Vendor Identification : Richtek : 1000b	R	1000
[3:0]	CHIP_REV	Chip Revision	R	0001
Address	01	BUCKcontrol1		
Bit	Name	Description	R/W	Reset Value
[7:2]	Buck1Output[5:0]	Buck1 output voltage regulation 000000 : 0.7V, 25mV per step 000001 : 0.725V ... 101100 : 1.8V ... 111111 : 1.8V	R/W	Option
[1:0]	Buck1VRC	VRC setting 00 : 25mV/10μs, 01 : 50mV/10μs, 10 : 100mV/10μs, 11 : 200mV/10μs	R/W	Option
Address	02	BUCKcontrol2		
Bit	Name	Description	R/W	Reset Value
[7:2]	Buck2Output[5:0]	Buck2 output voltage regulation 000000 : 0.7V, 25mV per step 000001 : 0.725V ... 101100 : 1.8V ... 111111 : 1.8V	R/W	Option
[1:0]	Buck2VRC	VRC setting 00 : 25mV/10μs, 01 : 50mV/10μs, 10 : 100mV/10μs, 11 : 200mV/10μs	R/W	Option
Address	03	BUCKcontrol3		
Bit	Name	Description	R/W	Reset Value
[7:2]	Buck3Output[5:0]	Buck3 output voltage regulation 000000 : 0.7V, 50mV per step 000001 : 0.75V ... 111010 : 3.6V ... 111111 : 3.6V	R/W	Option
[1:0]	Buck3VRC	VRC setting 00 : 50mV/10μs, 01 : 100mV/10μs, 10 : 200mV/10μs, 11 : 400mV/10μs	R/W	Option

Address	04	BUCKcontrol4			
Bit	Name	Description	R/W	Reset Value	
[7:2]	Buck4Output[5:0]	Buck4 output voltage regulation 000000 : 0.7V, 50mV per step 000001 : 0.75V ... 1111010 : 3.6V ... 1111111 : 3.6V	R/W	Option	
[1:0]	Buck4VRC	VRC setting 00 : 50mV/10μs, 01 : 100mV/10μs, 10 : 200mV/10μs, 11 : 400mV/10μs	R/W	Option	
Address	05	VRC Control			
Bit	Name	Description	R/W	Reset Value	
7	Buck1VRC_EN	Buck1 VRC 0 : disable - voltage ramps up to target voltage with one time 1 : enable - voltage ramps up to target voltage with slope control	R/W	Option	
6	Buck2VRC_EN	Buck2 VRC 0 - disable - voltage ramps up to target voltage with one time 1 - enable - voltage ramps up to target voltage with slope control	R/W	Option	
5	Buck3VRC_EN	Buck3 VRC 0 : disable - voltage ramps up to target voltage with one time 1 : enable - voltage ramps up to target voltage with slope control	R/W	Option	
4	Buck4VRC_EN	Buck4 VRC 0 : disable - voltage ramps up to target voltage with one time 1 : enable - voltage ramps up to target voltage with slope control	R/W	Option	
[3:0]	Reserved		R/W	0000	
Address	06	BUCK Mode			
Bit	Name	Description	R/W	Reset Value	
7	Buck1mode	Buck1 mode 0 : Force PWM 1 : Auto Mode (PSM/PWM)	R/W	1	
6	Buck2mode	Buck2 mode 0 : Force PWM 1 : Auto Mode (PSM/PWM)	R/W	1	
5	Buck3mode	Buck3 mode 0 : Force PWM 1 : Auto Mode (PSM/PWM)	R/W	1	

4	Buck4mode	Buck4 mode 0 : Force PWM 1 : Auto Mode (PSM/PWM)	R/W	1
3	Buck1oms	Buck1 output off mode state 0 : floating 1 : Ground-discharged	R/W	1
2	Buck2oms	Buck2 output off mode state 0 : floating 1 : Ground-discharged	R/W	1
1	Buck3oms	Buck3 output off mode state 0 : floating 1 : Ground-discharged	R/W	1
0	Buck4oms	Buck4 output off mode state 0 : floating 1 : Ground-discharged	R/W	1
Address	07	LDOcontrol1		
Bit	Name	Description	R/W	Reset Value
7	Reserved		R/W	0
[6:0]	LDO1OUT[6:0]	LDO1 output voltage regulation 0000000 : 1.6V, 25mV per step 0000001 : 1.625V ... 0101000 : 3.6V (MAX) ... 1111111 : 3.6V (MAX)	R/W	Option
Address	08	LDOcontrol2		
Bit	Name	Description	R/W	Reset Value
7	Reserved		R/W	0
[6:0]	LDO2OUT[6:0]	LDO2 output voltage regulation 0000000 : 1.6V, 25mV per step 0000001 : 1.625V ... 0101000 : 3.6V (MAX) ... 1111111 : 3.6V (MAX)	R/W	Option
Address	09	LDOcontrol3		
Bit	Name	Description	R/W	Reset Value
7	Reserved		R/W	0
[6:0]	LDO3OUT[6:0]	LDO3 output voltage regulation 0000000 : 1.6V, 25mV per step 0000001 : 1.625V ... 0101000 : 3.6V (MAX) ... 1111111 : 3.6V (MAX)	R/W	Option

Address	0A	LDOcontrol4		
Bit	Name	Description	R/W	Reset Value
7	Reserved		R/W	0
[6:0]	LDO4OUT[6:0]	LDO4 output voltage regulation 0000000 : 3 V, 25mV per step 0000001 : 3.025V ... 0011000 : 3.6V (MAX) ... 1111111 : 3.6V (MAX)	R/W	Option
Address	0B	LDOcontrol5		
Bit	Name	Description	R/W	Reset Value
7	Reserved		R/W	0
[6:0]	LDO5OUT[6:0]	LDO5 output voltage regulation 0000000 : 3V, 25mV per step 0000001 : 3.025V ... 0011000 : 3.6V (MAX) ... 1111111 : 3.6V (MAX)	R/W	Option
Address	0C	LDOcontrol6		
Bit	Name	Description	R/W	Reset Value
7	Reserved		R/W	0
[6:0]	LDO6OUT[6:0]	LDO6 output voltage regulation 0000000 : 3.0V, 25mV per step 0000001 : 3.025V ... 0011000 : 3.6V (MAX) ... 1111111 : 3.6V (MAX)	R/W	Option
Address	0D	LDOcontrol7		
Bit	Name	Description	R/W	Reset Value
7	Reserved		R/W	0
[6:0]	LDO7UT[6:0]	LDO7output voltage regulation 0000000 : 1.6V, 25mV per step 0000001 : 1.625V ... 0101000 : 3.6V (MAX) ... 1111111 : 3.6V (MAX)	R/W	Option

Address	0E	LDOcontrol8		
Bit	Name	Description	R/W	Reset Value
7	Reserved		R/W	0
[6:0]	LDO8T[6:0]	LDO8 output voltage regulation 0000000 : 1.6V, 25mV per step 0000001 : 1.625V ... 0101000 : 3.6V (MAX) ... 1111111 : 3.6V (MAX)	R/W	Option
Address	0F	LDOs off mode state		
Bit	Name	Description	R/W	Reset Value
7	LDO8oms	LDO8 output off mode state 0 : floating 1 : Ground-discharged	R/W	1
6	LDO7oms	LDO7 output off mode state 0 : floating 1 : Ground-discharged	R/W	1
5	LDO6oms	LDO6 output off mode state 0 : floating 1 : Ground-discharged	R/W	1
4	LDO5oms	LDO5 output off mode state 0 : floating 1 : Ground-discharged	R/W	1
3	LDO4oms	LDO4 output off mode state 0 : floating 1 : Ground-discharged	R/W	1
2	LDO3oms	LDO3 output off mode state 0 : floating 1 : Ground-discharged	R/W	1
1	LDO2oms	LDO2 output off mode state 0 : floating 1 : Ground-discharged	R/W	1
0	LDO1ms	LDO1 output off mode state 0 : floating 1 : Ground-discharged	R/W	1
Address	10	REBOOT/PWRHOLD delay time control		
Bit	Name	Description	R/W	Reset Value
[7:6]	Delayed2[1:0]	Delayed2 setting (00 : 100ms/01 : 500ms/10 : 1s/11 : 2s)	R/W	Option
[5:4]	Delayed1[1:0]	Delayed1 setting (00 : 100ms/01 : 500ms/10 : 1s/11 : 2s)	R/W	Option
[3:2]	THOLD[1:0]	THOLD setting (00 : 100ms/01 : 500ms/10 : 1s/11 : 2s)	R/W	Option
1	Reserved		R/W	0
0	DisTHOLD	Ignore THOLD Time. 0 : Keep PWRHOLD function. 1 : Ignore PWRHOLD function.	R/W	Option

Address	11		ON Event Setting		
Bit	Name	Description	R/W	Reset Value	
[7:5]	On_Event	Powered on because of 000 : PWRON key-pressed 001 : VIN plugged in 010 : from REBOOT pin event 111 : No event happen	R	111	
[4:0]	Reserved		R/W	0	
Address	12		VIN UVLO/Buck On/Off		
Bit	Name	Description	R/W	Reset Value	
[7:5]	VOFF setting	VIN UVLO 2.8V to 3.5V per 0.1V to power off PMIC 000 : 2.8V 001 : 2.9V 010 : 3V 011 : 3.1V (Default) 100 : 3.2V 101 : 3.3V 110 : 3.4V 111 : 3.5V	R/W	Option	
4	Reserved		R/W	0	
3	Buck4	Buck4 control (0 : Disable Buck4/1 : Enable Buck4)	R/W	Option	
2	Buck3	Buck3 control (0 : Disable Buck3/1 : Enable Buck3)	R/W	Option	
1	Buck2	Buck2 control (0 : Disable Buck2/1 : Enable Buck2)	R/W	Option	
0	Buck1	Buck1 control (0 : Disable Buck1/1 : Enable Buck1)	R/W	Option	
Address	13		LDOs On/Off		
Bit	Name	Description	R/W	Reset Value	
7	LDO8	LDO8 control (0 : Disable LDO8 / 1 : Enable LDO8)	R/W	Option	
6	LDO7	LDO7 control (0 : Disable LDO7 / 1 : Enable LDO7)	R/W	Option	
5	LDO6	LDO6 control (0 : Disable LDO6 / 1 : Enable LDO6)	R/W	Option	
4	LDO5	LDO5 control (0 : Disable LDO5 / 1 : Enable LDO5)	R/W	Option	
3	LDO4	LDO4 control (0 : Disable LDO4 / 1 : Enable LDO4)	R/W	Option	
2	LDO3	LDO3 control (0 : Disable LDO3 / 1 : Enable LDO3)	R/W	Option	
1	LDO2	LDO2 control (0 : Disable LDO2 / 1 : Enable LDO2)	R/W	Option	
0	LDO1	LDO1 control (0 : Disable LDO1 / 1 : Enable LDO1)	R/W	Option	

Address	14	PWRON(Power On Key) time Parameters Setting / $\overline{\text{RESET}}$ delay		
Bit	Name	Description	R/W	Reset Value
[7:6]	START_TIME	Startup time setting 00 : 100us (pressing time - low level) 01 : 100ms 10 : 1s 11 : 2s	R/W	Option
[5:4]	L_PRESS_TIME	Long-press time setting (after Power-On, 00 : 1s (falling edge to rising edge) 01 : 1.5s 10 : 2s 11 : 2.5s Sending short/long-press IRQ to CPU ex :1.5s => low time < 1.5s (short IRQ) => low time > 1.5s but < 6s(shutdown time) (long IRQ) => low time > 6s(shutdown time) (shutdown)	R/W	Option
[3:2]	SHDN_PRESS	Key-press forced shutdown time setting 00 : 4s (pressing time : low level) 01 : 6s 10 : 8s 11 : 10s	R/W	Option
[1:0]	$\overline{\text{RESET_DLY}}$	RESET signal delay after the last power startup is done 00 : 10ms 01 : 50ms 10 : 100ms 11 : 200ms	R/W	Option
Address	15	SHDN Control		
Bit	Name	Description	Read/Write	Reset Value
7	SHDN_CTRL	Power Off setting by CPU, after set, 100ms delayed power off 0 : Normal operation 1 : Disable the PMIC output	R/W	Option
6	SHDN_TIMING	Disable Buck/LDO only for normal power off (SHDN_CTRL=1) 0 : disable at the same time 1 : contrary to the startup timing (first_on-last_off)	R/W	Option
[5:4]	SHDN_DLYTIME	Delayed shutdown time after send the (PWRON)key-press-forced-shutdown IRQ (when IRQ is disable, there is no delay) 00 : 100ms 01 : 500ms 10 : 1s 11 : 2s	R/W	Option
[3:0]	Reserved		R/W	0000

Address	16	Powered off conditions enable setting		
Bit	Name	Description	Read/Write	Reset Value
7	BCK1LV_ENSHDN	Buck1 output voltage low SHDN 0 : disable this event. 1 : enable this event	R/W	0
6	BCK2LV_ENSHDN	Buck2 output voltage low SHDN 0 : disable this event. 1 : enable this event	R/W	0
5	BCK3LV_ENSHDN	Buck3 output voltage low SHDN 0 : disable this event. 1 : enable this event	R/W	0
4	BCK4LV_ENSHDN	Buck4 output voltage low SHDN 0 : disable this event. 1 : enable this event	R/W	0
3	PWRON_ENSHDN	PWRON key-pressed forced SHDN 0 : disable this event. 1 : enable this event	R/W	1
2	OT_ENSHDN	Over temperature SHDN 0 : disable this event. 1 : enable this event	R/W	1
1	VINLV_ENSHDN	VIN voltage low (VOFF) (Set by reg) SHDN 0 : disable this event. 1 : enable this event	R/W	0
0	Reserved		R/W	0
Address	17	OFF Event (Only reset by POR)		
Bit	Name	Description	Read/Write	Reset Value
[7:4]	OFF_Event	Powered off because of (Only shows last power-off event) 0000 : VIN voltage low (VOFF) (Set by reg) 0001 : Buck1 output voltage low 0010 : Buck2 output voltage low 0011 : Buck3 output voltage low 0100 : PWRON key-pressed forced shutdown 0101 : Power Off register setting 0110 : Over temperature event 0111 : Reboot restart. 1000 : Buck4 output voltage low 1001 : PWR_HOLD fail. 1010 : No event happen. 1111 : No event happen	R	1111
[3:0]	Reserved		R	0000
Address	18 to 27	16 bytes registers Data Cache (Only reset by POR)	R/W	0

IRQ_PMIC (Power Channels)				
Address	28	IRQ Enable1		
Bit	Name	Description	Read/Write	Reset Value
7	OT_IRQ	Internal over-temperature was triggered, IRQ enable	R/W	1
6	Bck1LV_IRQ	Buck1 output voltage equal 66% x V _{Target} , IRQ enable	R/W	1
5	Bck2LV_IRQ	Buck2 output voltage equal 66% x V _{Target} , IRQ enable	R/W	1
4	Bck3LV_IRQ	Buck3 output voltage equal 66% x V _{Target} , IRQ enable	R/W	1
3	Bck4LV_IRQ	Buck4 output voltage equal 66% x V _{Target} , IRQ enable	R/W	1
2	PWRONSP_IRQ	PWRON short press, IRQ enable (32μs deglitch time)	R/W	0
1	PWRONLP_IRQ	PWRON long press, IRQ enable (32μs deglitch time)	R/W	0
0	SYSLV_IRQ	VIN voltage is lower than VOFF, IRQ enable	R/W	0
Address	29	IRQ Status1		
Bit	Name	Description	Read/Write	Reset Value
7	OT	Internal over-temperature	R	0
6	Bck1LV	Buck1 output voltage equal 66% x V _{Target}	R	0
5	Bck2LV	Buck2 output voltage equal 66% x V _{Target}	R	0
4	Bck3LV	Buck3 output voltage equal 66% x V _{Target}	R	0
3	Bck4LV	Buck4 output voltage equal 66% x V _{Target}	R	0
2	PWRONSP	PWRON short press (32μs deglitch time)	R	0
1	PWRONLP	PWRON long press (32μs deglitch time)	R	0
0	VINLV	VIN voltage is lower than VOFF	R	0
Address	2A	IRQ Enable2		
Bit	Name	Description	Read/Write	Reset Value
7	KPSHDN_IRQ	Key-press forced shutdown, IRQ enable	R/W	1
6	PWRONR_IRQ	PWRON press rising edge, IRQ enable	R/W	0
5	PWRONF_IRQ	PWRON press falling edge, IRQ enable	R/W	0
[4:0]	Reserved		R	0000
Address	2B	IRQ Status2		
Bit	Name	Description	Read/Write	Reset Value
7	KPSHDN	Key-press forced shutdown	R	0
6	PWRONR	PWRON press rising edge	R	0
5	PWRONF	PWRON press falling edge	R	0
[4:2]	Reserved		R	000
1	OTW125	Internal 125°C pre-warning over-temperature.	R	0
0	OTW100	Internal 100°C pre-warning over-temperature.	R	0

Address	2C		PMU On/Off Sequence1		
Bit	Name	Description (Setting on/off sequence priority) (0000 : off, 0001 : first on, 1100 : last on) (The sequence is planed by first on last off)		Read/Write	Reset Value
[7:4]	Buck2_Seq[3:0]	Setting Buck2 on/off sequence priority		R/W	Option
[3:0]	Buck1_Seq[3:0]	Setting Buck1 on/off sequence priority		R/W	Option
Address	2D		PMU On/Off Sequence2		
Bit	Name	Description (Setting on/off sequence priority) (0000 : off, 0001 : first on, 1100 : last on) (The sequence is planed by first on last off)		Read/Write	Reset Value
[7:4]	Buck4_Seq[3:0]	Setting Buck4 on/off sequence priority		R/W	Option
[3:0]	Buck3_Seq[3:0]	Setting Buck3 on/off sequence priority		R/W	Option
Address	2E		PMU On/Off Sequence3		
Bit	Name	Description (Setting on/off sequence priority) (0000 : off, 0001 : first on, 1100 : last on) (The sequence is planed by first on last off)		Read/Write	Reset Value
[7:4]	LDO2_Seq[3:0]	Setting LDO2 on/off sequence priority		R/W	Option
[3:0]	LDO1_Seq[3:0]	Setting LDO1 on/off sequence priority		R/W	Option
Address	2F		PMU On/Off Sequence4		
Bit	Name	Description (Setting on/off sequence priority) (0000 : off, 0001 : first on, 1100 : last on) (The sequence is planed by first on last off)		Read/Write	Reset Value
[7:4]	LDO4_Seq[3:0]	Setting LDO4 on/off sequence priority		R/W	Option
[3:0]	LDO3_Seq[3:0]	Setting LDO3 on/off sequence priority		R/W	Option
Address	30		PMU On/Off Sequence5		
Bit	Name	Description (Setting on/off sequence priority) (0000 : off, 0001 : first on, 1100 : last on) (The sequence is planed by first on last off)		Read/Write	Reset Value
[7:4]	LDO6_Seq[3:0]	Setting LDO6 on/off sequence priority		R/W	Option
[3:0]	LDO5_Seq[3:0]	Setting LDO5 on/off sequence priority		R/W	Option
Address	31		PMU On/Off Sequence5		
Bit	Name	Description (Setting on/off sequence priority) (0000 : off, 0001 : first on, 1100 : last on) (The sequence is planed by first on last off)		Read/Write	Reset Value
[7:4]	LDO8_Seq[3:0]	Setting LDO8 on/off sequence priority		R/W	Option
[3:0]	LDO7_Seq[3:0]	Setting LDO7 on/off sequence priority		R/W	Option
Address	32		Soft-Start Control		
Bit	Name	Description		Read/Write	Reset Value
[7:6]	Reserved			R	Option

[5:2]	Soft-Start End Control @ MASK_GPIO = 0 (External Enable pin define)	0000 : First turn on channel decide the RESET_DLY time. 0001 : Buck1 decide the RESET_DLY time. 0100 : Buck1 decide the RESET_DLY time. 0101 : LDO1 decide the RESET_DLY time. 1100 : LDO8 decide the RESET_DLY time. 1111 : LDO8 decide the RESET_DLY time.	R/W	Option
[1:0]	Soft-Start Voltage level / time soft-start control.	Voltage Level 00 : When output voltage arrives to 80% V _{Target} , next channel will turn on. Soft-start time interval (TSS) : 01 : 1ms 10 : 4ms 11 : 8ms	R/W	Option
Address	33	Buck Syn-Clock Control		
Bit	Name	Description	Read/Write	Reset Value
[7:6]	VCO_VRC	VCO input voltage slop. 00: 25mV/10μs, 01: 25mV/20μs 10: 25mV/40μs, 11: 25mV/80μs Note : The VCO's voltage input range is 0.375V to 1.8V and the output frequency is 450kHz to 2MHz.	R/W	Option
[5:0]	VCO_DVS	VCO input voltage DVS control 000000 : 0.375V (450kHz) 111001 : 1.8V (2MHz) 111111 : 1.8V (2MHz)	R/W	Option
Address	34	Buck Syn-Clock Spread Spectrum Control		
Bit	Name	Description	Read/Write	Reset Value
[7:1]	Reserved		R/W	0000000
0	SSOSC	Buck Clock Spread Spectrum Control 0 : Disable spread spectrum function. 1 : Turn on spread spectrum function.	R/W	Option
Address	3A	EEPROM (MTP) Control		
Bit	Name	Description	Read/Write	Reset Value
[7:6]	Reserved		R/W	00
5	MTP Page 2 Read	Read MTP Page 2	R	0
4	MTP Page 1 Read	Read MTP Page 1	R	0
[3:2]	Reserved		R/W	00
1	MTP Page 2 write	Write MTP Page 2, and MTP also needs to be logic high.	W	0
0	MTP Page 1 write	Write MTP Page 1, and MTP also needs to be logic high.	W	0

Table 3. I²C to MTP Mapping Table
MTP Page-1

MTP Address	I ² C Register Address	Bit7	Bit6	Bit5	Bit4	Bit3	Bit2	Bit1	Bit0	
0X00	0X01	Function	BUCKcontrol1							
		Meaning	Buck1Output[5:0]						Buck1VRC	
		Default	0	1	0	1	0	0	0	0
		Read/Write	R/W	R/W	R/W	R/W	R/W	R/W	R/W	R/W
		Reset Condition	A	A	A	A	A	A	B	B
0X01	0X02	Function	BUCKcontrol2							
		Meaning	Buck2Output[5:0]						Buck2VRC	
		Default	0	1	1	0	0	0	0	0
		Read/Write	R/W	R/W	R/W	R/W	R/W	R/W	R/W	R/W
		Reset Condition	A	A	A	A	A	A	B	B
0X02	0X03	Function	BUCKcontrol3							
		Meaning	Buck3Output[5:0]						Buck3VRC	
		Default	0	1	0	0	0	0	0	0
		Read/Write	R/W	R/W	R/W	R/W	R/W	R/W	R/W	R/W
		Reset Condition	A	A	A	A	A	A	B	B
0X03	0X04	Function	BUCKcontrol4							
		Meaning	Buck4Output[5:0]						Buck4VRC	
		Default	1	1	0	1	0	1	0	0
		Read/Write	R/W	R/W	R/W	R/W	R/W	R/W	R/W	R/W
		Reset Condition	A	A	A	A	A	A	B	B
0X0D	0X05	Function	VRC Control							
		Meaning	Buck1V RC_EN	Buck2V RC_EN	Buck3V RC_EN	Buck4V RC_EN	Reserved	Reserved	Reserved	Reserved
		Default	0	0	0	0	0	0	0	0
		Read/Write	R/W	R/W	R/W	R/W	R/W	R/W	R/W	R/W
		Reset Condition	B	B	B	B	B	B	B	B
0X04	0X07	Function	LDOcontrol1							
		Meaning	Reserved	LDO1OUT[6:0]						
		Default	0	0	0	0	1	0	0	0
		Read/Write	R/W	R/W	R/W	R/W	R/W	R/W	R/W	R/W
		Reset Condition	B	A	A	A	A	A	A	A

MTP Address	I ² C Register Address	Bit7	Bit6	Bit5	Bit4	Bit3	Bit2	Bit1	Bit0		
0X05	0X08	Function	LDOcontrol2								
		Meaning	Reserved	LDO2OUT[6:0]							
		Default	0	0	1	0	0	1	0	0	
		Read/Write	R/W	R/W	R/W	R/W	R/W	R/W	R/W	R/W	
		Reset Condition	B	A	A	A	A	A	A	A	
0X06	0X09	Function	LDOcontrol3								
		Meaning	Reserved	LDO3OUT[6:0]							
		Default	0	0	0	0	1	0	0	0	
		Read/Write	R/W	R/W	R/W	R/W	R/W	R/W	R/W	R/W	
		Reset Condition	B	A	A	A	A	A	A	A	
0x07	0x0A	Function	LDOcontrol4								
		Meaning	Reserved	LDO4OUT[6:0]							
		Default	0	0	0	0	1	1	0	0	
		Read/Write	R/W	R/W	R/W	R/W	R/W	R/W	R/W	R/W	
		Reset Condition	B	A	A	A	A	A	A	A	
0x08	0x0B	Function	LDOcontrol5								
		Meaning	Reserved	LDO5OUT[6:0]							
		Default	0	0	0	0	1	1	0	0	
		Read/Write	R/W	R/W	R/W	R/W	R/W	R/W	R/W	R/W	
		Reset Condition	B	A	A	A	A	A	A	A	
0x09	0x0C	Function	LDOcontrol6								
		Meaning	Reserved	LDO6OUT[6:0]							
		Default	0	0	0	0	1	1	0	0	
		Read/Write	R/W	R/W	R/W	R/W	R/W	R/W	R/W	R/W	
		Reset Condition	B	A	A	A	A	A	A	A	
0x0A	0x0D	Function	LDOcontrol7								
		Meaning	Reserved	LDO7OUT[6:0]							
		Default	0	0	0	0	1	0	0	0	
		Read/Write	R/W	R/W	R/W	R/W	R/W	R/W	R/W	R/W	
		Reset Condition	B	A	A	A	A	A	A	A	
0x0B	0x0E	Function	LDOcontrol8								
		Meaning	Reserved	LDO8OUT[6:0]							
		Default	0	1	0	0	0	1	0	0	
		Read/Write	R/W	R/W	R/W	R/W	R/W	R/W	R/W	R/W	
		Reset Condition	B	A	A	A	A	A	A	A	

MTP Address	I ² C Register Address	Bit7	Bit6	Bit5	Bit4	Bit3	Bit2	Bit1	Bit0	
0x0C	0x12	Function	VIN UVLO (update default value after power on)							
		Meaning	VOFF setting			Reserved	Reserved	Reserved	Reserved	Reserved
		Default	1	1	1	0	0	0	0	0
		Read/Write	R/W	R/W	R/W	R/W	R/W	R/W	R/W	R/W
		Reset Condition	A	A	A	B	B	B	B	B
0x0F	No mapping	Function	x							
		Meaning	Reserved	Reserved	Reserved	Reserved	Reserved	Reserved	Reserved	Reserved
		Default	0	0	0	0	0	0	0	0
		Read/Write	R/W	R/W	R/W	R/W	R/W	R/W	R/W	R/W
		Reset Condition	B	B	B	B	B	B	B	B

MTP Page-2

MTP Address	I ² C Register Address	Bit7	Bit6	Bit5	Bit4	Bit3	Bit2	Bit1	Bit0	
0x00	0x10	Function	REBOOT/PWRHOLD delay time control							
		Meaning	Delayed2[1:0]		Delayed1[1:0]		THOLD		Reserved	DisTHOLD
		Default	1	0	1	0	0	0	0	1
		Read/Write	R/W	R/W	R/W	R/W	R/W	R/W	R/W	R/W
		Reset Condition	B	B	B	B	B	B	B	B
0x01	0x14	Function	PWRON time Parameters Setting / $\overline{\text{RESET}}$ delay							
		Meaning	START_TIME		L_PRESS_TIME		SHDN_PRESS		$\overline{\text{RESET_DLY}}$	
		Default	0	0	0	0	0	0	1	0
		Read/Write	R/W	R/W	R/W	R/W	R/W	R/W	R/W	R/W
		Reset Condition	A	A	A	A	A	A	A	A
0x02	0x15	Function	SHDN Control							
		Meaning	SHDN_CTRL	SHDN_TIMING	SHDN_DLYTIME		Reserved	Reserved	Reserved	Reserved
		Default	0	1	0	0	0	0	0	0
		Read/Write	R/W	R/W	R/W	R/W	R/W	R/W	R/W	R/W
		Reset Condition	B	B	B	B	B	B	B	B
0x03	0x2C	Function	PMU On/Off Sequence1							
		Meaning	Buck2_Seq[3:0]				Buck1_Seq[3:0]			
		Default	0	0	0	1	0	0	0	1
		Read/Write	R/W	R/W	R/W	R/W	R/W	R/W	R/W	R/W
		Reset Condition	A	A	A	A	A	A	A	A
0x04	0x2D	Function	PMU On/Off Sequence2							
		Meaning	Buck4_Seq[3:0]				Buck3_Seq[3:0]			
		Default	0	0	1	0	0	0	1	0
		Read/Write	R/W	R/W	R/W	R/W	R/W	R/W	R/W	R/W
		Reset Condition	A	A	A	A	A	A	A	A
0x05	0x2E	Function	PMU On/Off Sequence3							
		Meaning	LDO2_Seq[3:0]				LDO1_Seq[3:0]			
		Default	0	0	1	0	0	0	1	0
		Read/Write	R/W	R/W	R/W	R/W	R/W	R/W	R/W	R/W
		Reset Condition	A	A	A	A	A	A	A	A

MTP Address	I ² C Register Address	Bit7	Bit6	Bit5	Bit4	Bit3	Bit2	Bit1	Bit0	
0x06	0x2F	Function	PMU On/Off Sequence4							
		Meaning	LDO4_Seq[3:0]				LDO3_Seq[3:0]			
		Default	0	0	1	1	0	0	0	0
		Read/Write	R/W	R/W	R/W	R/W	R/W	R/W	R/W	R/W
		Reset Condition	A	A	A	A	A	A	A	A
0x07	0x30	Function	PMU On/Off Sequence5							
		Meaning	LDO6_Seq[3:0]				LDO5_Seq[3:0]			
		Default	0	0	0	0	0	0	1	1
		Read/Write	R/W	R/W	R/W	R/W	R/W	R/W	R/W	R/W
		Reset Condition	A	A	A	A	A	A	A	A
0x08	0x31	Function	PMU On/Off Sequence6							
		Meaning	LDO8_Seq[3:0]				LDO7_Seq[3:0]			
		Default	0	0	1	1	0	0	1	1
		Read/Write	R/W	R/W	R/W	R/W	R/W	R/W	R/W	R/W
		Reset Condition	A	A	A	A	A	A	A	A
0x09	0x32	Function	Soft-Start Control							
		Meaning	Reversed	Reversed	Soft-Start End Select @MASK_GPIO=1				Soft-Start Control	
		Default	0	0	0	0	0	0	0	0
		Read/Write	R/W	R/W	R/W	R/W	R/W	R/W	R/W	R/W
		Reset Condition	B	B	A	A	A	A	B	B
0x0A	0x33	Function	Buck Syn-Clock Control							
		Meaning	VCO_VRC			VCO_DVS				
		Default	0	0	1	1	1	0	0	1
		Read/Write	R/W	R/W	R/W	R/W	R/W	R/W	R/W	R/W
		Reset Condition	B	B	A	A	A	A	A	A
0x0B	0x34	Function	Buck Syn-Clock Spread Spectrum Control							
		Meaning	Reversed	Reversed	Reversed	Reversed	Reversed	Reversed	Reversed	SSOSC
		Default	0	0	0	0	0	0	0	1
		Read/Write	R/W	R/W	R/W	R/W	R/W	R/W	R/W	R/W
		Reset Condition	B	B	B	B	B	B	B	B
0x0C	No mapping	Function	x							
		Meaning	Reserved	Reserved	Reserved	Reserved	Reserved	Reserved	Reserved	Reserved
		Default	0	0	0	0	0	0	0	0
		Read/Write	R/W	R/W	R/W	R/W	R/W	R/W	R/W	R/W
		Reset Condition	B	B	B	B	B	B	B	B

MTP Address	I ² C Register Address	Bit7	Bit6	Bit5	Bit4	Bit3	Bit2	Bit1	Bit0	
0x0D	No mapping	Function	x							
		Meaning	Reserved	Reserved	Reserved	Reserved	Reserved	Reserved	Reserved	Reserved
		Default	0	0	0	0	0	0	0	0
		Read/Write	R/W	R/W	R/W	R/W	R/W	R/W	R/W	R/W
		Reset Condition	B	B	B	B	B	B	B	B
0x0E	No mapping	Function	x							
		Meaning	Reserved	Reserved	Reserved	Reserved	Reserved	Reserved	Reserved	Reserved
		Default	0	0	0	0	0	0	0	0
		Read/Write	R/W	R/W	R/W	R/W	R/W	R/W	R/W	R/W
		Reset Condition	B	B	B	B	B	B	B	B
0x0F	No mapping	Function	x							
		Meaning	Reserved	Reserved	Reserved	Reserved	Reserved	Reserved	Reserved	Reserved
		Default	0	0	0	0	0	0	0	0
		Read/Write	R/W	R/W	R/W	R/W	R/W	R/W	R/W	R/W
		Reset Condition	B	B	B	B	B	B	B	B

Reset Condition

A	Reset by MTP (Register 0x12 VOFF Setting).
B	Reset when VIN < 1.7V.

Outline Dimension

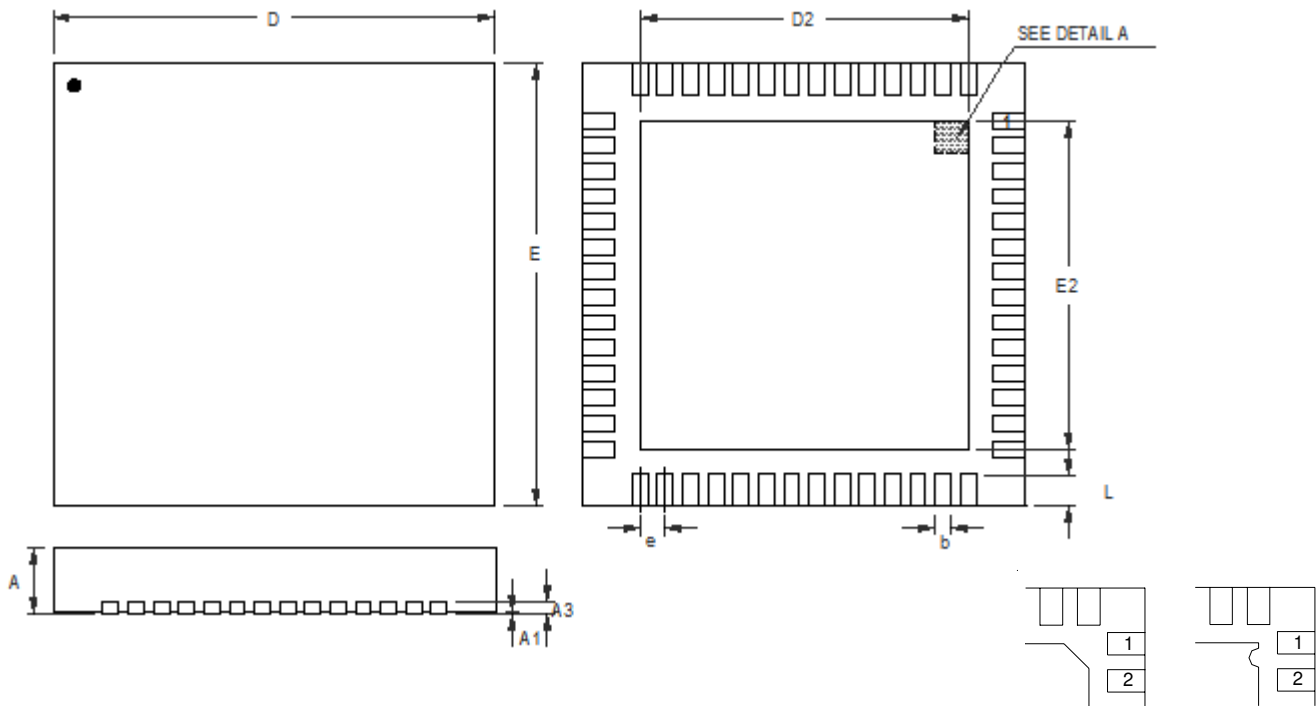

DETAIL A

Pin #1 ID and Tie Bar Mark Options

Note : The configuration of the Pin #1 identifier is optional, but must be located within the zone indicated.

Symbol	Dimensions In Millimeters		Dimensions In Inches	
	Min	Max	Min	Max
A	0.700	0.800	0.028	0.031
A1	0.000	0.050	0.000	0.002
A3	0.175	0.250	0.007	0.010
b	0.150	0.250	0.006	0.010
D	6.900	7.100	0.272	0.280
D2	5.150	5.250	0.203	0.207
E	6.900	7.100	0.272	0.280
E2	5.150	5.250	0.203	0.207
e	0.400		0.016	
L	0.350	0.450	0.014	0.018

W-Type 56L QFN 7x7 Package

Richtek Technology Corporation

14F, No. 8, Tai Yuen 1st Street, Chupei City

Hsinchu, Taiwan, R.O.C.

Tel: (8863)5526789

Richtek products are sold by description only. Richtek reserves the right to change the circuitry and/or specifications without notice at any time. Customers should obtain the latest relevant information and data sheets before placing orders and should verify that such information is current and complete. Richtek cannot assume responsibility for use of any circuitry other than circuitry entirely embodied in a Richtek product. Information furnished by Richtek is believed to be accurate and reliable. However, no responsibility is assumed by Richtek or its subsidiaries for its use; nor for any infringements of patents or other rights of third parties which may result from its use. No license is granted by implication or otherwise under any patent or patent rights of Richtek or its subsidiaries.