

Automotive IPD Series

8ch Low Side Switch

BD8LB65AEFV-C

General Description

BD8LB65AEFV-C is an 8-channel SPI-input low side switch for automotive and industrial application. It has built-in open load detection function, short ground detection function, over current protection function, thermal shutdown function, and active clamp function.

Features

- AEC-Q100 Qualified^(Note 1)
 - Monolithic Power Management IC with Control Block (CMOS) and a Power MOSFET Mounted on a Single Chip
 - Channel Control/error can be Detected by 16 bit SPI Commands.
 - Built-in Open Load Detection Function (OLD)
 - Built-in Short Ground Detection Function (SGD)
 - Built-in Over Current Protection Function (OCP)
 - Built-in Thermal Shutdown Function(TSD)
 - Built-in Active Clamp Function
 - Built-in Synchro Mode
 - Built-in Limp Home Mode
 - Surface-mount HTSSOP-B20 Packaging
- ^(Note 1) Grade1

Key Specifications

- Power Supply Operating Range: 4.0 V to 5.5 V
- On State Resistance: 650 mΩ (Typ)
- Over Current Threshold Value: 0.5 A/1.0 A (Min)
- Active Clamp Energy: 125 mJ
- Operating Temperature Range Tj:-40 °C to +150 °C

Package

HTSSOP-B20

W (Typ) x D (Typ) x H (Max)

6.5 mm x 6.4 mm x 1.0 mm

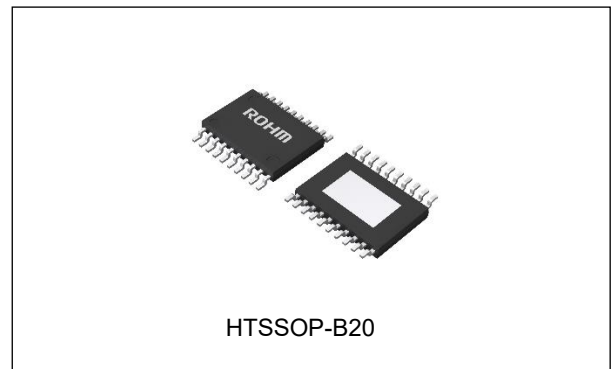

Application

- Driving Resistive and Inductive Load

Typical Application Circuit

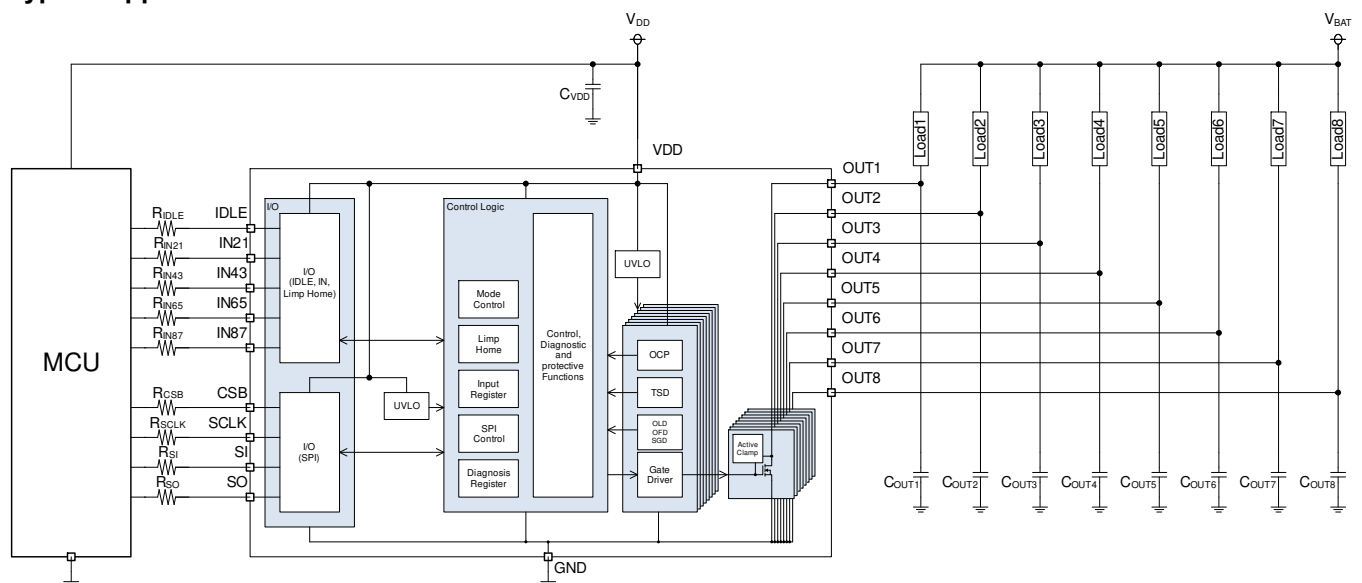

○Product structure : Silicon integrated circuit ○This product has no designed protection against radioactive rays.

Contents

General Description	1
Features.....	1
Application	1
Key Specifications	1
Package.....	1
Typical Application Circuit	1
Contents	2
Pin Configuration	3
Pin Descriptions.....	3
Definition.....	4
Block Diagram	4
Absolute Maximum Ratings	5
Thermal Resistance	6
Recommended Operating Conditions.....	10
Electrical Characteristics.....	10
Typical Performance Curves.....	12
Measurement Circuit.....	22
Timing Chart	24
Synchro Mode.....	26
Limp Home Mode	27
SPI Specification.....	28
Register Map	32
Over Current Protection Function	34
Thermal Shutdown Function	35
Open Load Detection (OLD)	36
Output Overhead Fault Detection Function (OFD).....	37
Short Ground Detection (SGD).....	38
Application Example	40
Selection of Components Externally Connected.....	40
I/O Equivalence Circuits.....	41
Operational Notes.....	42
Ordering Information.....	45
Marking Diagram	45
Physical Dimension and Packing Information	46
Revision History.....	47

Pin Configuration

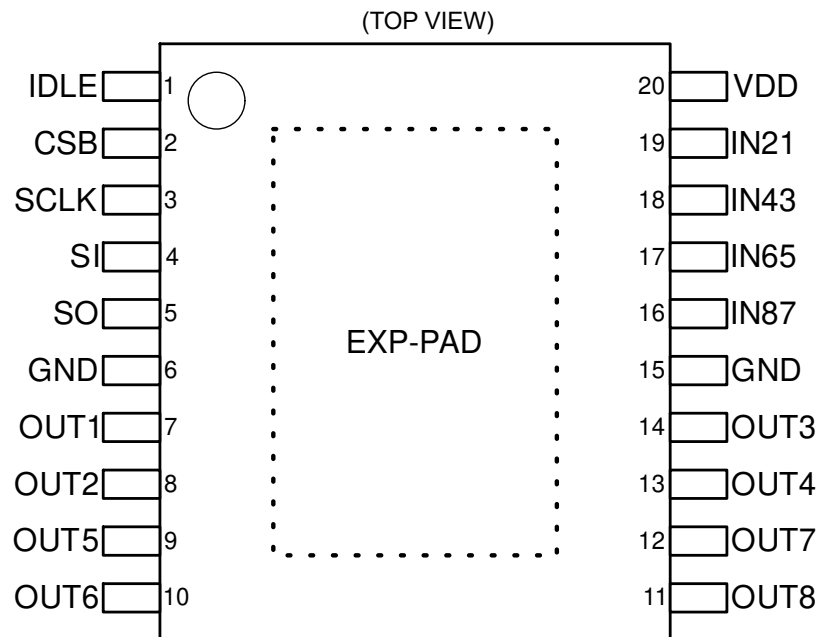

Pin Descriptions

Pin No.	Pin Name	Function
1	IDLE	Limp home mode control This pin is connected to GND via an internal pull-down resistor.
2	CSB	SPI enable This pin is connected to VDD via an internal pull-up resistor.
3	SCLK	Serial clock input This pin is connected to GND via an internal pull-down resistor.
4	SI	Serial data input This pin is connected to GND via an internal pull-down resistor.
5	SO	Serial data output
6	GND	GND
7	OUT1	ch1 output
8	OUT2	ch2 output
9	OUT5	ch5 output
10	OUT6	ch6 output
11	OUT8	ch8 output
12	OUT7	ch7 output
13	OUT4	ch4 output
14	OUT3	ch3 output
15	GND	GND
16	IN87	ch7, ch8 control ^(Note 1) This pin is connected to GND via an internal pull-down resistor.
17	IN65	ch5, ch6 control ^(Note 1) This pin is connected to GND via an internal pull-down resistor.
18	IN43	ch3, ch4 control ^(Note 1) This pin is connected to GND via an internal pull-down resistor.
19	IN21	ch1, ch2 control ^(Note 1) This pin is connected to GND via an internal pull-down resistor.
20	VDD	Analog power supply
-	EXP-PAD	Be sure to connect EXP-PAD to GND.

(Note 1) Controlled channels can be changed by accessing DIRCTRL register from the SPI.

Definition

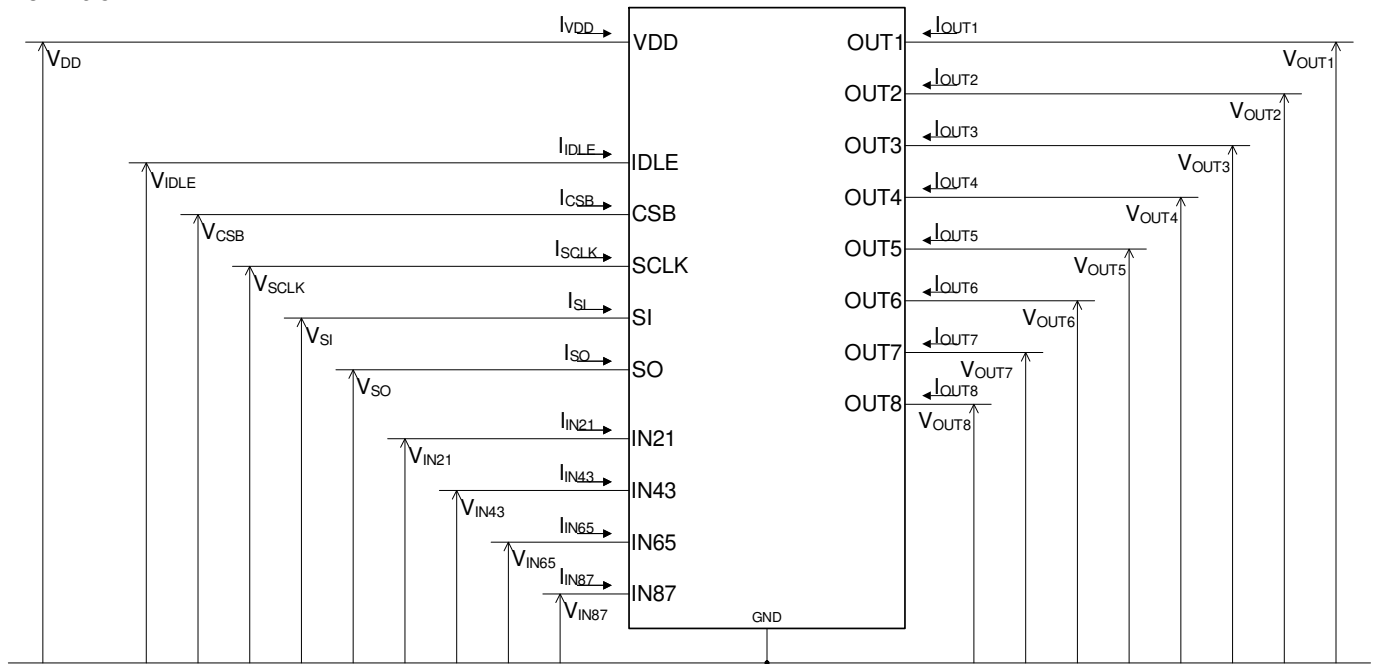

Block Diagram

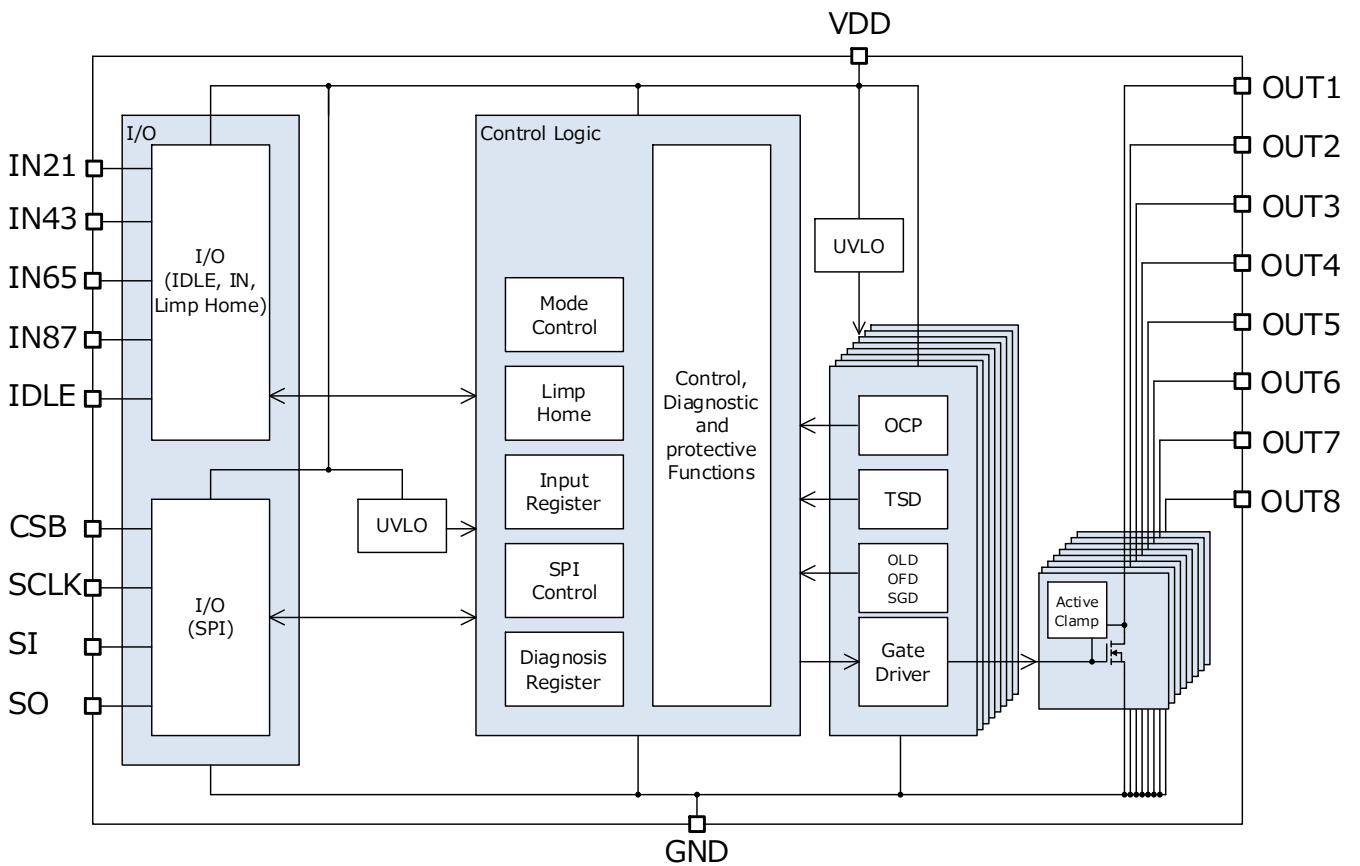

Absolute Maximum Ratings (Tj = 25 °C)

Parameter	Symbol	Rating	Unit
VDD Power Supply Voltage	V _{DD}	-0.3 to +7	V
Output Voltage (Power MOS Output)	V _{OUT1-8}	-0.3 to (Internal Limit) ^(Note 1)	V
Output Current (Power MOS Output)	I _{OUT1-8}	(Internal Limit) ^(Note 2)	A
Output Voltage (SPI)	V _{SO}	-0.3 to +7	V
Input Voltage (IDLE)	V _{IDLE}	-0.3 to +7	V
Input Voltage (SPI)	V _{CSB} , V _{SCLK} , V _{SI}	-0.3 to +7	V
Input Voltage (IN87, IN65, IN43, IN21)	V _{IN87} , V _{IN65} , V _{IN43} , V _{IN21}	-0.3 to +7	V
Storage Temperature Range	T _{stg}	-55 to +150	°C
Maximum Junction Temperature	T _{jmax}	150	°C
Active Clamp Energy (Single Pulse) T _{j(START)} = 25 °C, I _{OUT1-8(START)} = 0.4 A	E _{AS1-8(25 °C)}	125	mJ
Active Clamp Energy (Single Pulse) ^(Note 3) T _{j(START)} = 150 °C, I _{OUT1-8(START)} = 0.4 A	E _{AS1-8(150 °C)}	25	mJ
Active Clamp Energy (Single Pulse) T _{j(START)} = 25 °C, I _{OUT1-8(START)} = 0.8 A, Synchro Mode	E _{S, AS1-8(25 °C)}	57	mJ
Active Clamp Energy (Single Pulse) ^(Note 3) T _{j(START)} = 150 °C, I _{OUT1-8(START)} = 0.8 A, Synchro Mode	E _{S, AS1-8(150 °C)}	19	mJ
Active Clamp Energy (Repetitive) ^{(Note 3)(Note 4)} T _{j(START)} = 125 °C, I _{OUT(START)} = 0.2 A	E _{AR(125 °C)}	12	mJ
Active Clamp Energy (Repetitive) ^{(Note 3)(Note 4)} T _{j(START)} = 125 °C, I _{OUT(START)} = 0.4 A, Synchro Mode	E _{S, AR(125 °C)}	9	mJ

(Note 1) Limited by the active clamp function.

(Note 2) Limited by the over current protection function. The over current detection value can be adjusted in two levels.

(Note 3) Not 100 % are tested.

(Note 4) 2M cycles, All channel input.

Caution 1: Operating the IC over the absolute maximum ratings may damage the IC. The damage can either be a short circuit between pins or an open circuit between pins and the internal circuitry. Therefore, it is important to consider circuit protection measures, such as adding a fuse, in case the IC is operated over the absolute maximum ratings.

Caution 2: Should by any chance the maximum junction temperature rating be exceeded the rise in temperature of the chip may result in deterioration of the properties of the chip. In case of exceeding this absolute maximum rating, design a PCB with thermal resistance taken into consideration by increasing board size and copper area so as not to exceed the maximum junction temperature rating.

Caution 3: When IC is turned off with an inductive load, reverse energy has to be dissipated in the IC. This energy can be calculated by the following equation:

$$E_L = \frac{1}{2} L I_{OUT(START)}^2 \times \left(1 - \frac{V_{BAT}}{V_{BAT} - V_{OUT(CL)}} \right)$$

Where:

L is the inductance of the inductive load.

I_{OUT(START)} is the output current at the time of turning off.

V_{OUT(CL)} is the output clamp voltage.

The IC integrates the active clamp function to internally absorb the reverse energy E_L which is generated when the inductive load is turned off. When the active clamp operates, the thermal shutdown function does not work. Decide a load so that the reverse energy E_L is active clamp energy E_{AS} (Figure 1.), E_{S,AS} (Figure 2.) or under when inductive load is used.

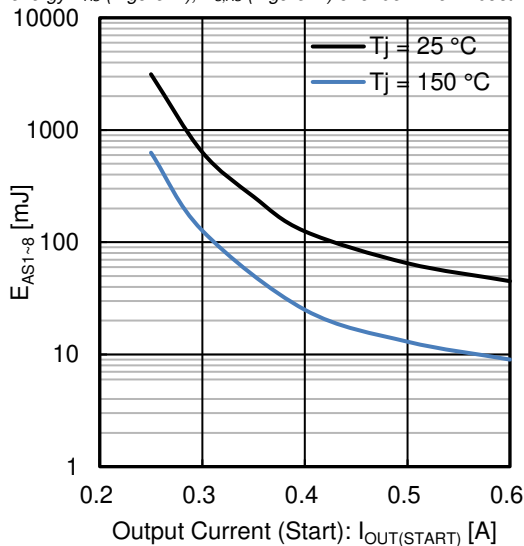

Figure 1. Active Clamp Energy (Single Pulse) vs Output Current

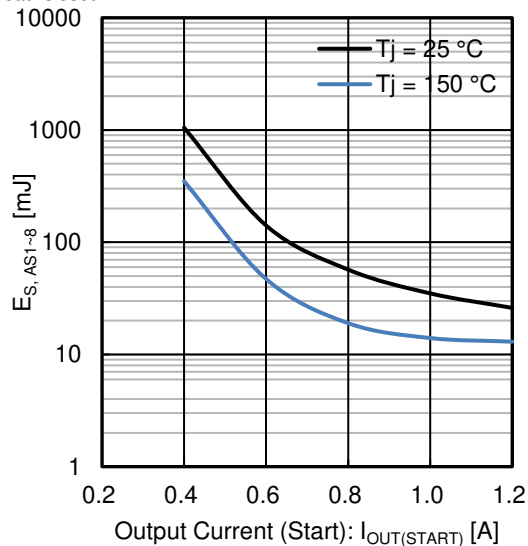

Figure 2. Active Clamp Energy (Single Pulse) Synchro Mode vs Output Current

Thermal Resistance (Note 1)

Parameter	Symbol	Typ	Unit	Condition
HTSSOP-B20				
Between Junction and Surroundings Temperature Thermal Resistance	θ_{JA}	96.6	°C/W	1s (Note 2)
		35.1	°C/W	2s (Note 3)
		24.5	°C/W	2s2p (Note 4)

(Note 1) The thermal impedance is based on JESD51-2A(Still-Air) standard.

(Note 2) JESD51-3 standard FR4 114.3 mm x 76.2 mm x 1.57 mm 1-layer (1s)

(Top copper foil: ROHM recommended Footprint + wiring to measure, 2 oz. copper.)

(Note 3) JESD51-5 standard FR4 114.3 mm x 76.2 mm x 1.60 mm 2-layers (2s).

(Top copper foil: ROHM recommended Footprint + wiring to measure/
Copper foil area on the reverse side of PCB: 74.2 mm x 74.2 mm, copper (top & reverse side) 2 oz)

(Note 4) JESD51-5/-7 standard FR4 114.3 mm x 76.2 mm x 1.60 mm 4-layers (2s2p)

(Top copper foil: ROHM recommended Footprint + wiring to measure/
2 inner layers and copper foil area on the reverse side of PCB: 74.2 mm x 74.2 mm, copper (top & reverse side/inner layers) 2 oz./1 oz.)

■ PCB Layout 1 layer (1s)

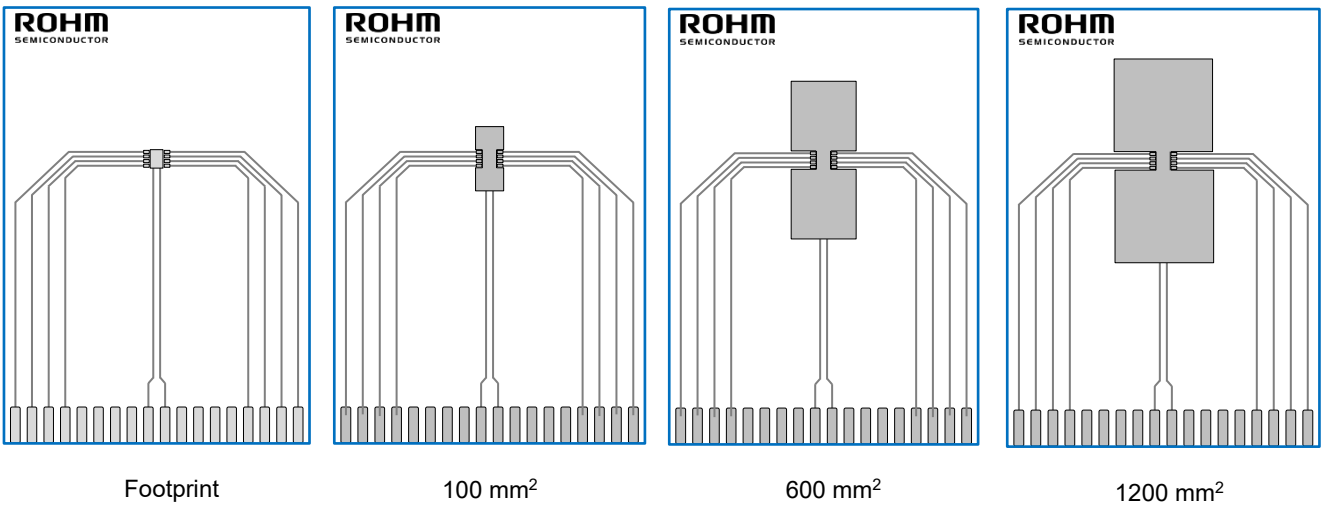

Figure 3. PCB Layout 1 Layer (1s)

Dimension	Value
Board Finish Thickness	1.57 mm ± 10 %
Board Dimension	76.2 mm x 114.3 mm
Board Material	FR4
Copper Thickness (Top Layer)	0.070 mm (Cu: 2 oz)
Copper Foil Area Dimension	Footprint/100 mm²/600 mm²/1200 mm²

Thermal Resistance – continued

■ PCB Layout 2 layers (2s)

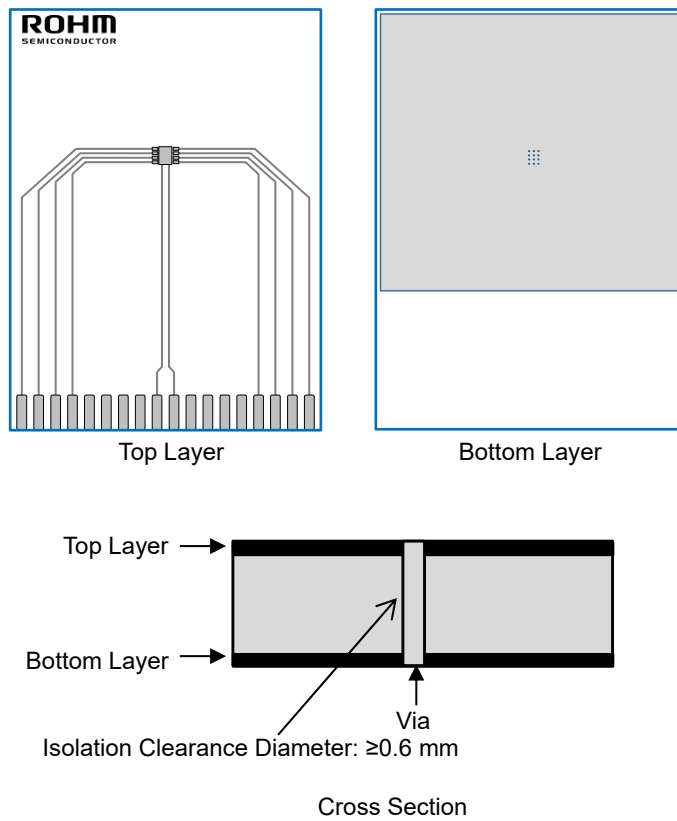

Figure 4. PCB-layout 2-layer (2s)

Dimension	Value
Board Finish Thickness	1.60 mm ± 10 %
Board Dimension	76.2 mm x 114.3 mm
Board Material	FR4
Copper Thickness (Top/Bottom Layers)	0.070 mm (Cu +Plating)
Thermal Via Separation/Diameter	1.2 mm/0.3 mm

Thermal Resistance – continued

■ PCB Layout 4 layers (2s2p)

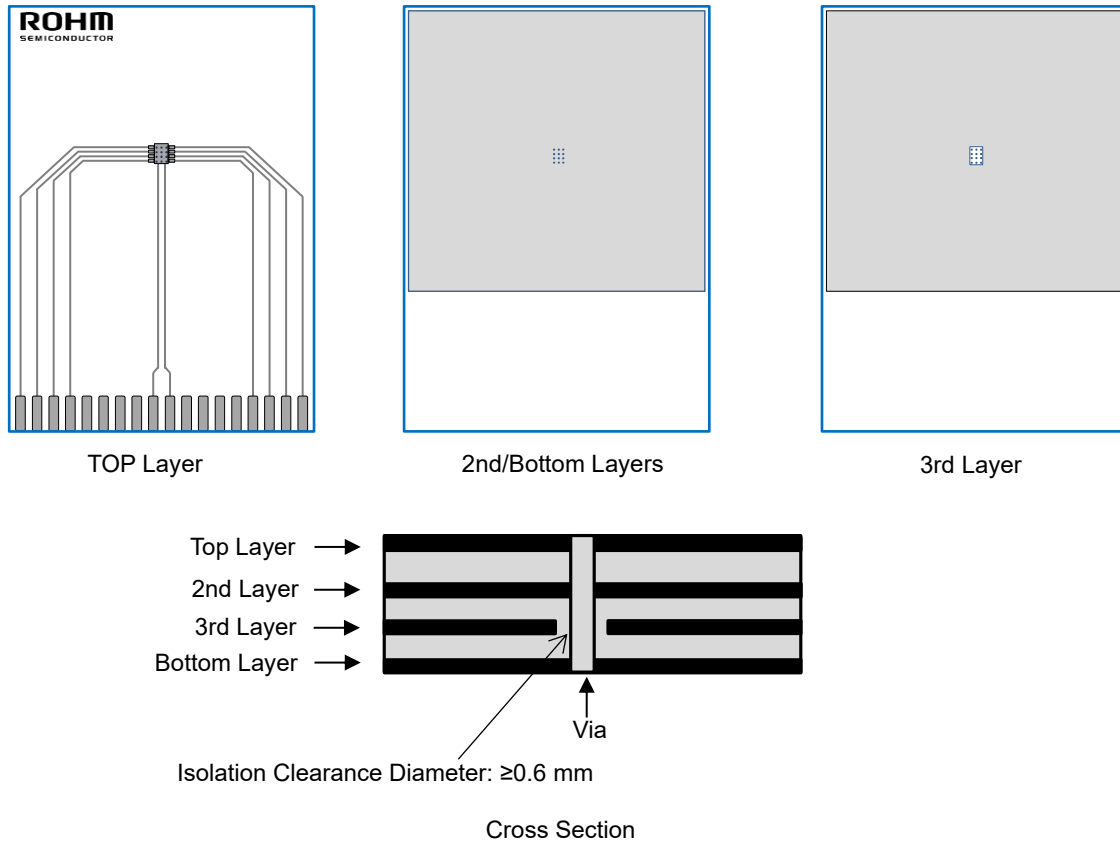

Figure 5. PCB-layout 4-layer (2s2p)

Dimension	Value
Board Finish Thickness	1.60 mm \pm 10 %
Board Dimension	76.2 mm x 114.3 mm
Board Material	FR4
Copper Thickness (Top/Bottom Layers)	0.070 mm (Cu +Plating)
Copper Thickness (Inner Layers)	0.035 mm
Thermal Vias Separation/Diameter	1.2 mm/0.3 mm

Thermal Resistance – continued

■ Transient Thermal Resistance (Single Pulse)

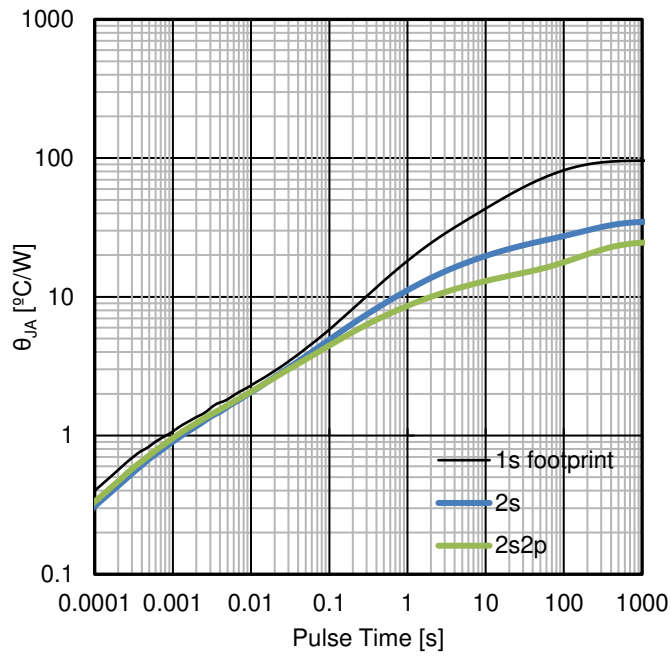

Figure 6. Transient Thermal Resistance

■ Thermal Resistance (θ_{JA} vs Copper Foil area 1s)

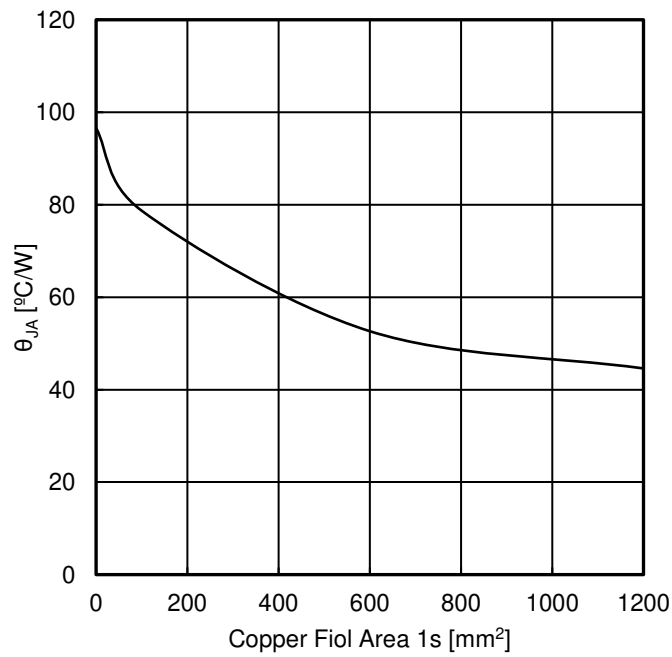

Figure 7. Thermal Resistance

Recommended Operating Conditions

Parameter	Symbol	Min	Typ	Max	Unit
VDD Power Supply Voltage	V _{DD}	4.0	5.0	5.5	V
Operating Temperature	T _{opr}	-40	+25	+150	°C

Electrical Characteristics (Unless otherwise specified V_{DD} = 4.0 V to 5.5 V, T_j = -40 °C to +150 °C)

Parameter	Symbol	Min	Typ	Max	Unit	Conditions
[Power Supply]						
VDD Standby Current	I _{VDDS}	-	0	40	μA	V _{IDLE} = 0 V V _{IN21} , V _{IN43} , V _{IN65} , V _{IN87} = 0 V
VDD Operating Current	I _{VDD}	-	1.2	2.4	mA	V _{IDLE} = 5 V V _{IN21} , V _{IN43} , V _{IN65} , V _{IN87} = 5 V OUTCTRLn[7:0] = FF ^(Note 1)
VDD Power On Reset Voltage	V _{PORA}	-	-	4.0	V	
[Input (IDLE, CSB, SCLK, SI, IN21, IN43, IN65, IN87)]						
Low Level Input Voltage	V _{IL}	0	-	V _{DD} × 0.2	V	
High Level Input Voltage	V _{IH}	V _{DD} × 0.7	-	V _{DD}	V	
Input Hysteresis Voltage	V _{HYS}	0.25	0.45	0.65	V	
Low Level Input Current 1 (except CSB)	I _{IL1}	-10	0	+10	μA	V _{IDLE} , V _{SCLK} , V _{SI} , V _{IN21} , V _{IN43} , V _{IN65} , V _{IN87} = 0 V
Low Level Input Current 2 (CSB)	I _{IL2}	-100	-50	-25	μA	V _{CSB} = 0 V
High Level Input Current 1 (except CSB)	I _{IH1}	25	50	100	μA	V _{IDLE} , V _{SCLK} , V _{SI} , V _{IN21} , V _{IN43} , V _{IN65} , V _{IN87} = 5 V
High Level Input Current 2 (CSB)	I _{IH2}	-10	0	+10	μA	V _{CSB} = 5 V
[Output (SO)]						
Low Level Output Voltage	V _{OL}	0	0.15	0.45	V	I _{SO} = 1 mA
High Level Output Voltage	V _{OH}	V _{DD} - 0.45	V _{DD} - 0.15	-	V	I _{SO} = -1 mA
Serial Out Output Leakage Current	I _{SO}	-5	0	+5	μA	V _{SO} = 0 V / 5.5 V
[Power MOS Output]						
Output On Resistance	R _{DS(ON)}	-	650	800	mΩ	V _{DD} = 5 V I _{OUT} = 0.2 A, T _j = 25 °C
		-	1200	1500	mΩ	V _{DD} = 5 V I _{OUT} = 0.2 A, T _j = 150 °C
Output Leakage Current	I _{OUT(L)}	-	0	1	μA	V _{OUT} = 30 V, T _j = 25 °C
		-	0.15	2.00	μA	V _{OUT} = 30 V, T _j = 150 °C
Output Clamp Voltage	V _{CL}	37	41	45	V	I _{OUT} = 1 mA, Output Off

(Note 1) Set by SPI control. Details are given in "Register Map". n represents the channel number.

Electrical Characteristics – continued (Unless otherwise specified, $V_{DD} = 4.0\text{ V to }5.5\text{ V}$, $T_j = -40\text{ }^\circ\text{C to }+150\text{ }^\circ\text{C}$)

Parameter	Symbol	Min	Typ	Max	Unit	Conditions
[Power MOS Output]						
Turn-On Time 1	t_{ON1}	-	-	50	μs	$R_L = 60\ \Omega$, $V_{IDLE} = 5\text{ V}$, $V_{BAT} = 12\text{ V}$, $SRCTRLn[1:0] = 00$ ^(Note 1)
Turn-Off Time 1	t_{OFF1}	-	-	50	μs	
Turn-On Time 2	t_{ON2}	-	-	200	μs	$R_L = 60\ \Omega$, $V_{IDLE} = 5\text{ V}$, $V_{BAT} = 12\text{ V}$, $SRCTRLn[1:0] = 10$ ^(Note 1)
Turn-Off Time 2	t_{OFF2}	-	-	200	μs	
Turn-On Time 3	t_{ON3}	-	-	25	μs	$R_L = 60\ \Omega$, $V_{IDLE} = 5\text{ V}$, $V_{BAT} = 12\text{ V}$, $SRCTRLn[1:0] = 01$ ^(Note 1)
Turn-Off Time 3	t_{OFF3}	-	-	25	μs	
Slew Rate (On) 1	SR_{ON1}	0.50	1.00	1.50	$\text{V}/\mu\text{s}$	$R_L = 60\ \Omega$, $V_{IDLE} = 5\text{ V}$, $V_{BAT} = 12\text{ V}$, $SRCTRLn[1:0] = 00$ ^(Note 1)
Slew Rate (Off) 1	SR_{OFF1}	0.50	1.00	1.50	$\text{V}/\mu\text{s}$	
Slew Rate (On) 2	SR_{ON2}	0.10	0.30	0.50	$\text{V}/\mu\text{s}$	$R_L = 60\ \Omega$, $V_{IDLE} = 5\text{ V}$, $V_{BAT} = 12\text{ V}$, $SRCTRLn[1:0] = 10$ ^(Note 1)
Slew Rate (Off) 2	SR_{OFF2}	0.10	0.30	0.50	$\text{V}/\mu\text{s}$	
Slew Rate (On) 3	SR_{ON3}	1.35	2.25	3.15	$\text{V}/\mu\text{s}$	$R_L = 60\ \Omega$, $V_{IDLE} = 5\text{ V}$, $V_{BAT} = 12\text{ V}$, $SRCTRLn[1:0] = 01$ ^(Note 1)
Slew Rate (Off) 3	SR_{OFF3}	1.35	2.25	3.15	$\text{V}/\mu\text{s}$	
PWM Output Range	f_{PWM}	-	-	5	kHz	$R_L = 60\ \Omega$, $V_{IDLE} = 5\text{ V}$, $V_{BAT} = 12\text{ V}$, $SRCTRLn[1:0] = 00$ ^(Note 1)
[Over Current Protection Function]						
Over Current Threshold Value 1	I_{OCP1}	0.50	0.85	1.30	A	$OCPCTRLn = '0'$ ^(Note 1)
Over Current Threshold Value 2	I_{OCP2}	1.00	1.70	2.40	A	$OCPCTRLn = '1'$ ^(Note 1)
Output Stop Time at OCP Detection	t_{OCP_OFF}	0.4	1.0	1.9	ms	$OCPCTRLn = '0' / '1'$ ^(Note 1)
[Open Load Detection Function]						
Open Load Detect Voltage	V_{OLD_DET}	1.2	2.2	3.2	V	DIAG_OLD/OFDn = '1' ^(Note 1) Output Off
Open Load Release Voltage	V_{OLD_REL}	1.6	2.6	3.6	V	
Output Sink Current	I_{OLD}	15	40	90	μA	$V_{OUT} = 12\text{ V}$
[Output Overhead Fault Detection Function]						
Output Overhead Detect Voltage	V_{OFD_DET}	1.6	2.6	3.6	V	DIAG_OLD/OFDn = '1' ^(Note 1) Output On
Output Overhead Release Voltage	V_{OFD_REL}	1.2	2.2	3.2	V	
[Short Ground Detection Function]						
Short Ground Detect Voltage	V_{SGD_DET}	0.3	1.0	1.5	V	DIAG_SGDn = '1' ^(Note 1) Output Off
Short Ground Release Voltage	V_{SGD_REL}	0.5	1.4	1.9	V	
Output Source Current	I_{SGD}	-40	-25	-10	μA	$V_{OUT} = 0\text{ V}$
[Thermal Shutdown Function]						
Detect Temperature ^(Note 2)	T_{TSD_DET}	150	175	200	$^\circ\text{C}$	
Hysteresis Temperature ^(Note 2)	T_{TSD_HYS}	-	15	-	$^\circ\text{C}$	

(Note 1) Set by SPI control. Details are given in "Register Map". n represents the channel number.

(Note 2) Not 100 % are tested.

Switching Time Measurement Waveform

Control by IN21 / IN43 / IN65 / IN87

$$SR_{ONn} = (V_{BAT} * 0.8) / t_{FALLn}$$

$$SR_{OFFn} = (V_{BAT} * 0.8) / t_{RISEn}$$

Control by SPI

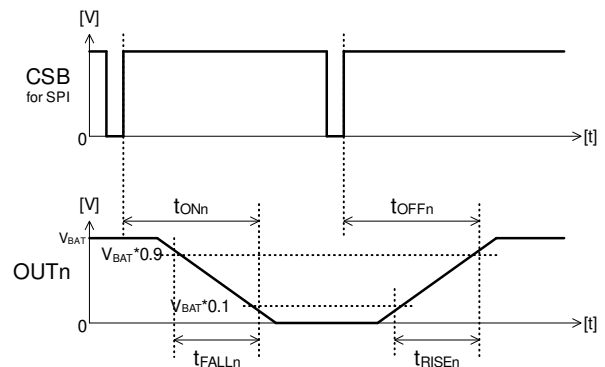
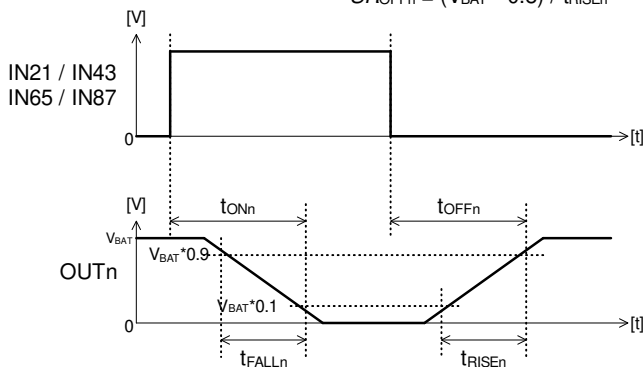

Typical Performance Curves

(Reference data) (Unless otherwise specified, $V_{DD} = 5\text{ V}$, $T_j = 25\text{ }^\circ\text{C}$)

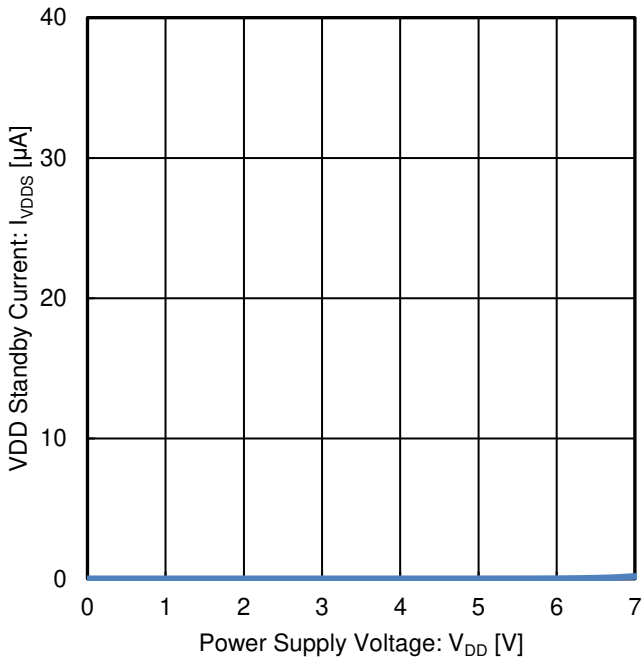

Figure 8. VDD Standby Current vs Power Supply Voltage

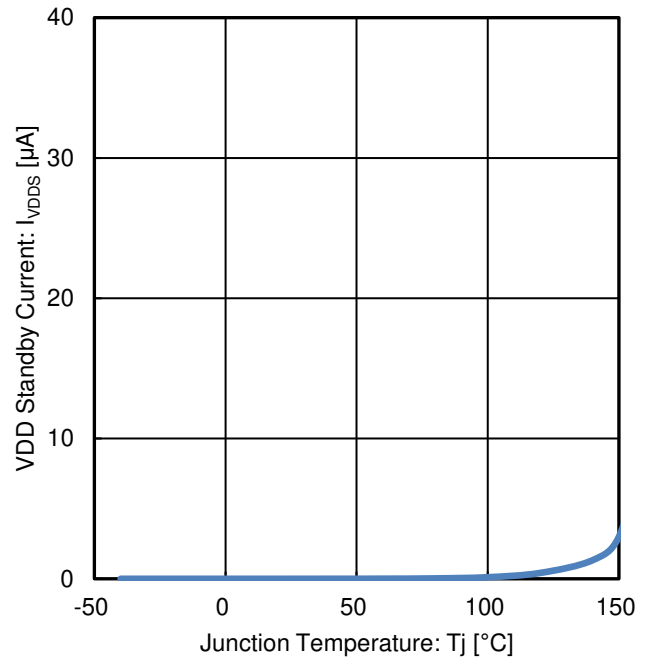

Figure 9. VDD Standby Current vs Junction Temperature

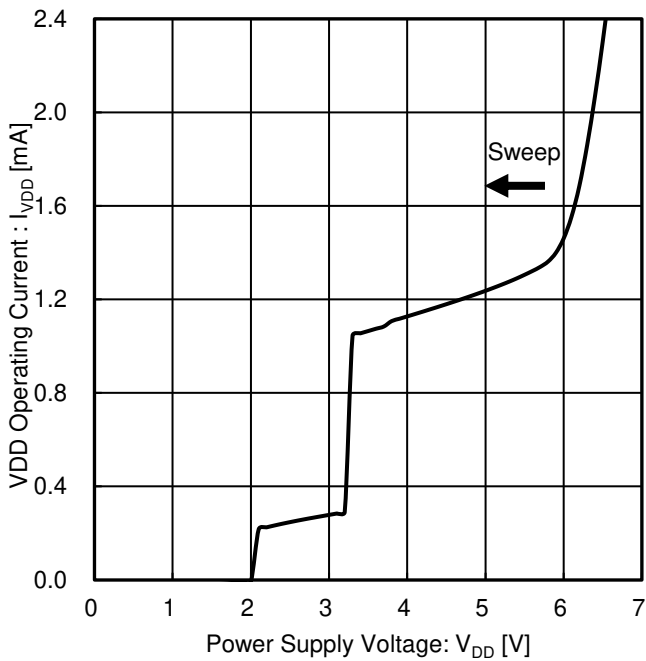

Figure 10. VDD Operating Current vs Power Supply Voltage

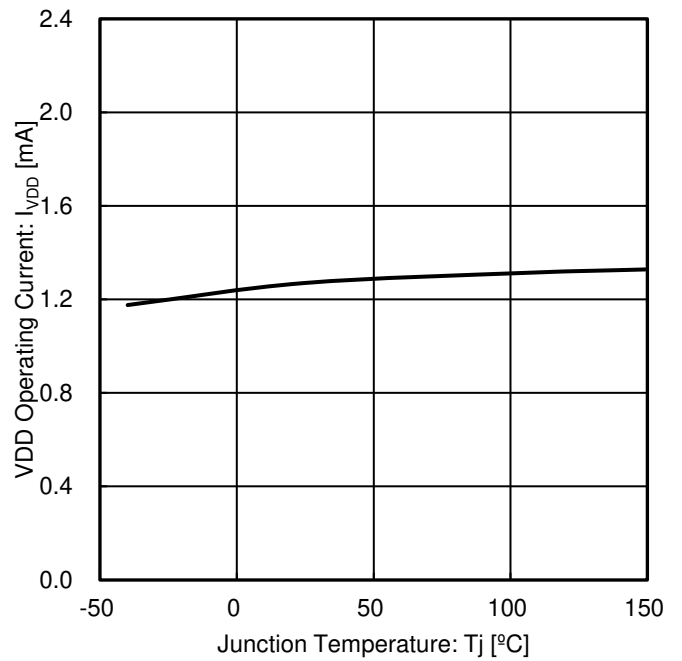

Figure 11. VDD Operating Current vs Junction Temperature

Typical Performance Curves – continued

(Reference data) (Unless otherwise specified, $V_{DD} = 5\text{ V}$, $T_j = 25\text{ }^\circ\text{C}$)

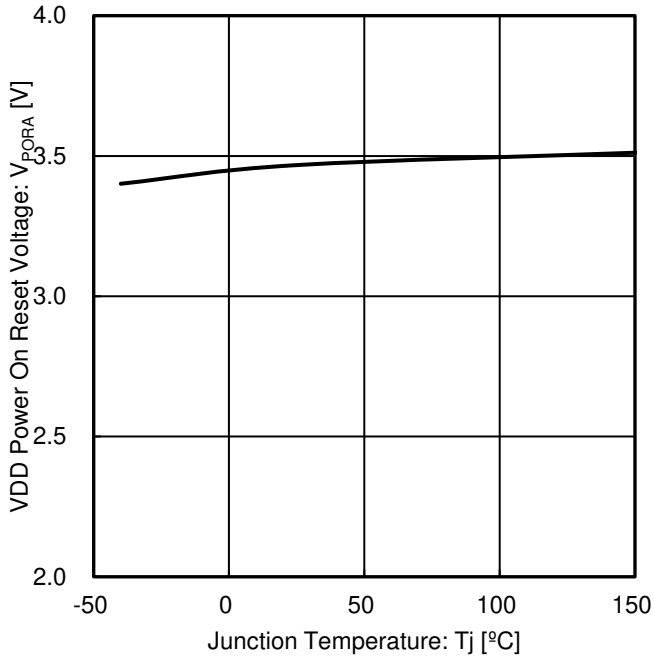

Figure 12. VDD Power On Reset Voltage vs Junction Temperature

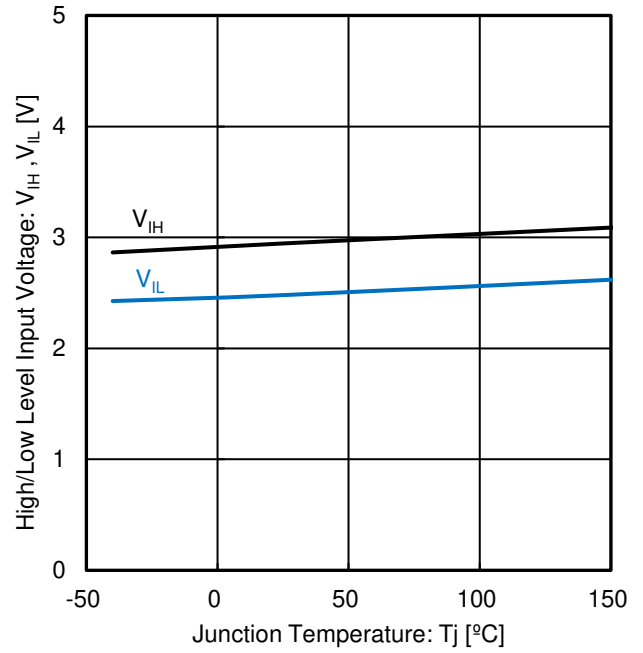

Figure 13. High/Low Level Input Voltage vs Junction Temperature

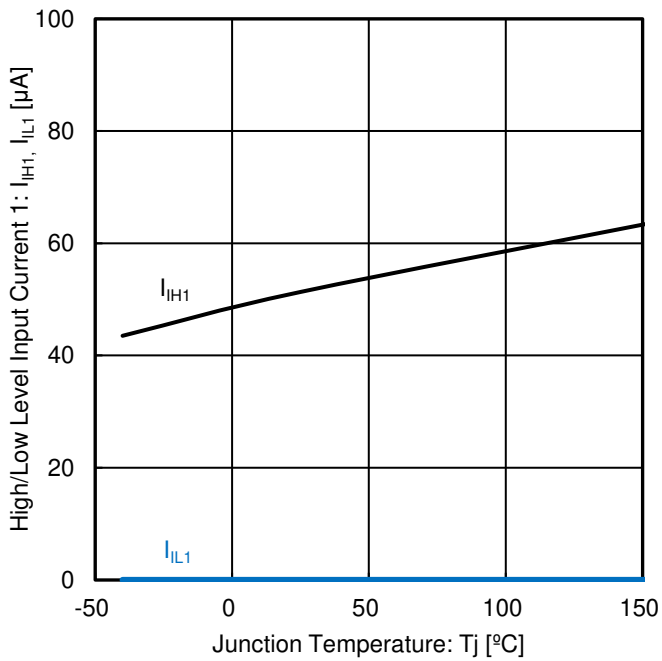

Figure 14. High/Low Level Input Current 1 vs Junction Temperature

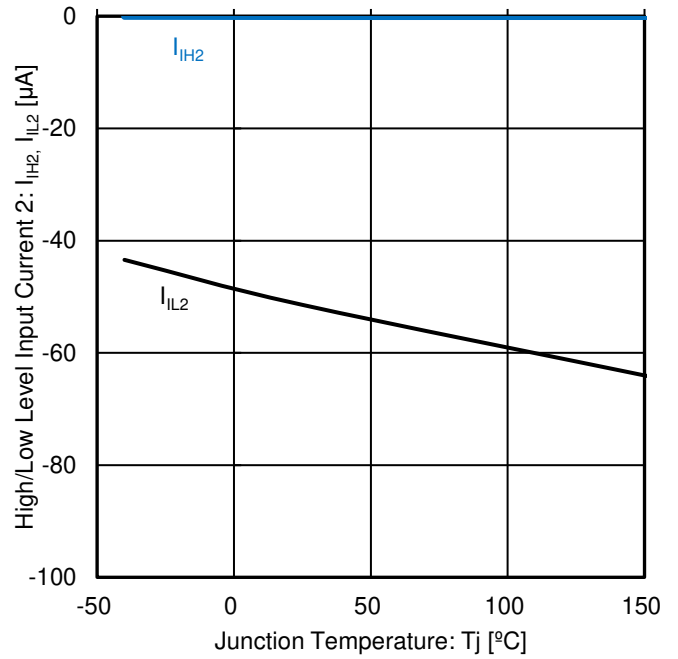

Figure 15. High/Low Level Input Current 2 vs Junction Temperature

Typical Performance Curves – continued

(Reference data) (Unless otherwise specified, $V_{DD} = 5\text{ V}$, $T_j = 25\text{ }^\circ\text{C}$)

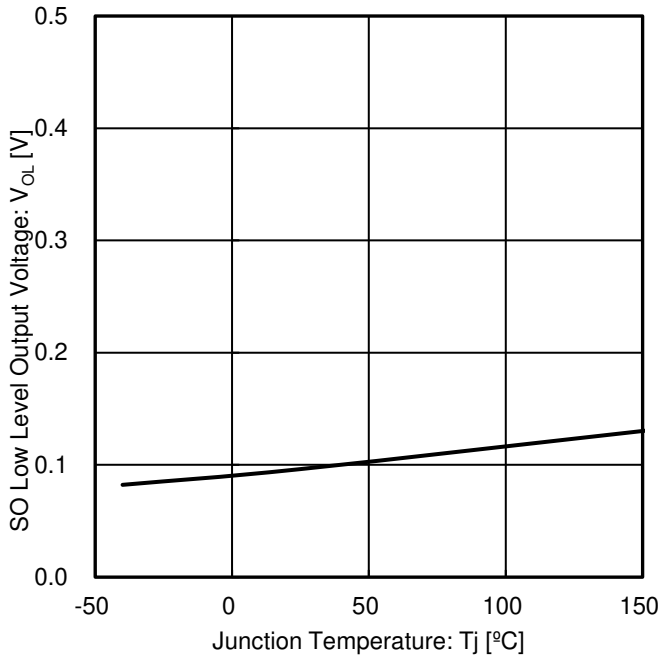

Figure 16. SO Low Level Output Voltage vs Junction Temperature

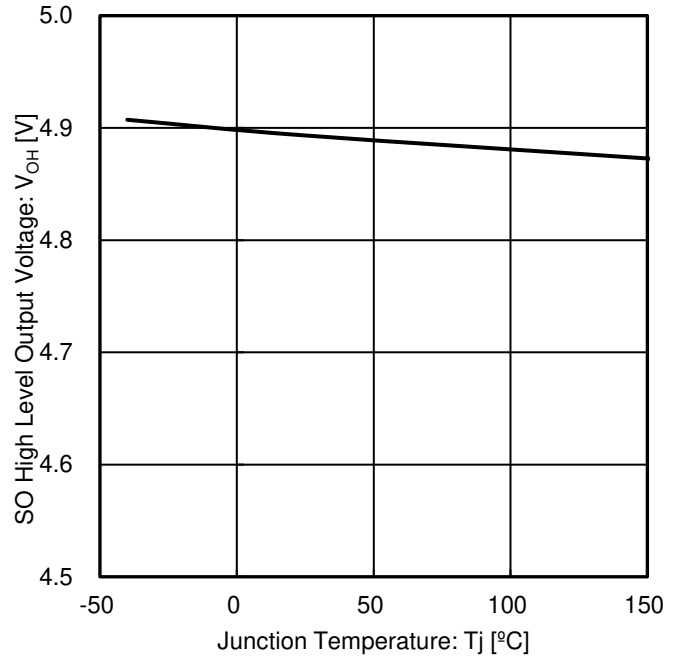

Figure 17. SO High Level Output Voltage vs Junction Temperature

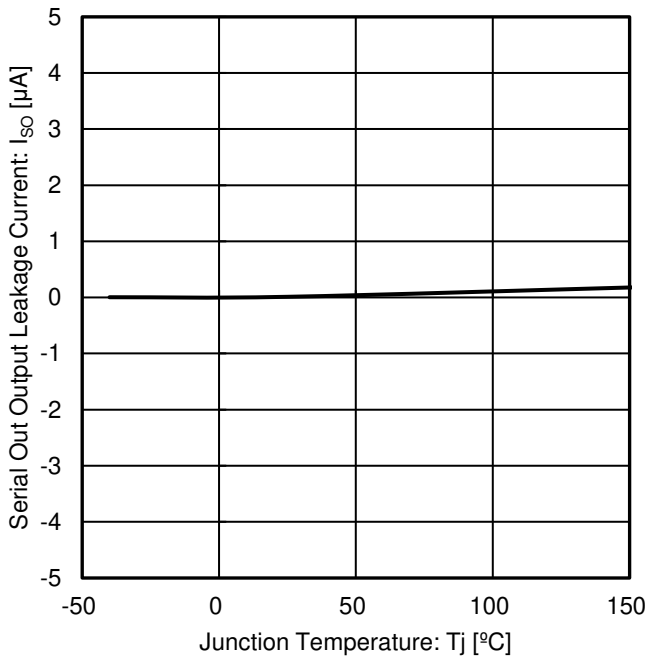

Figure 18. Serial Out Output Leakage Current vs Junction Temperature

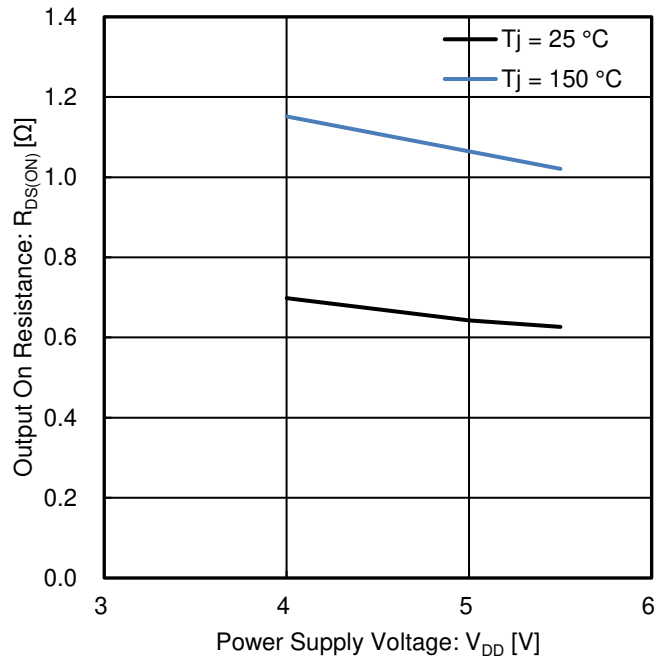

Figure 19. Output On Resistance vs Power Supply Voltage

Typical Performance Curves – continued

(Reference data) (Unless otherwise specified, $V_{DD} = 5\text{ V}$, $T_j = 25\text{ }^\circ\text{C}$)

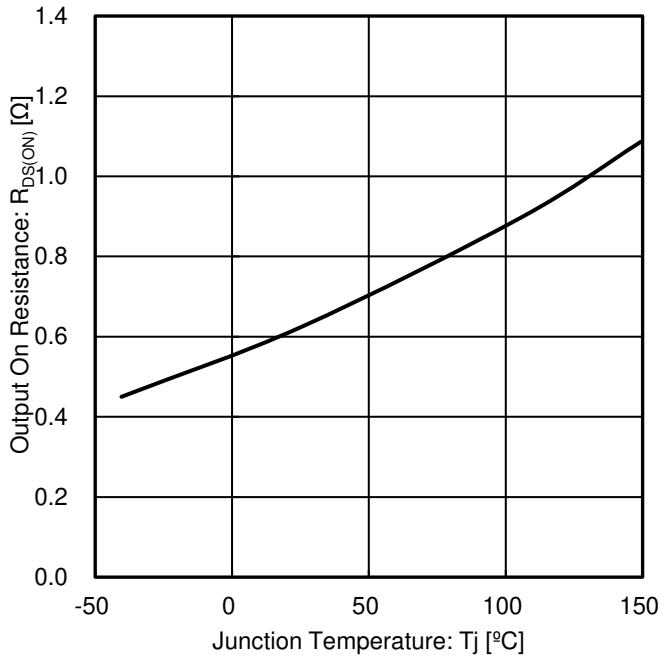

Figure 20. Output On Resistance vs Junction Temperature

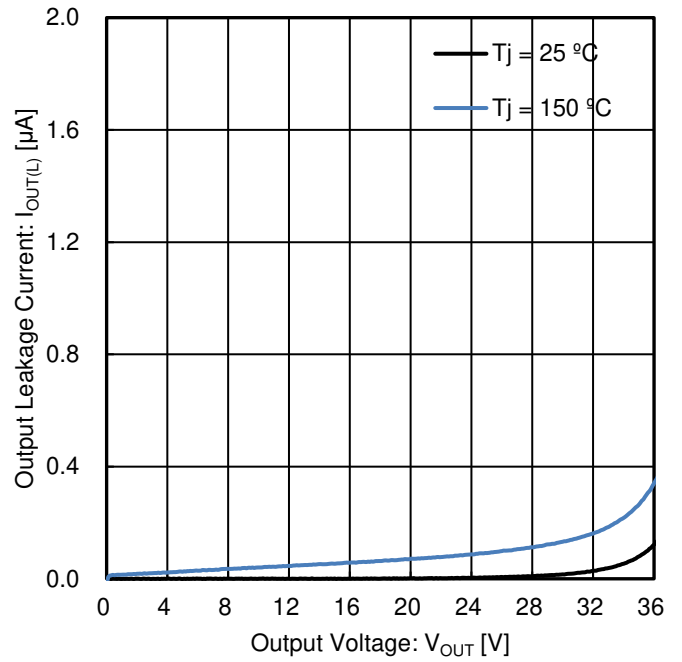

Figure 21. Output Leakage Current vs Output Voltage

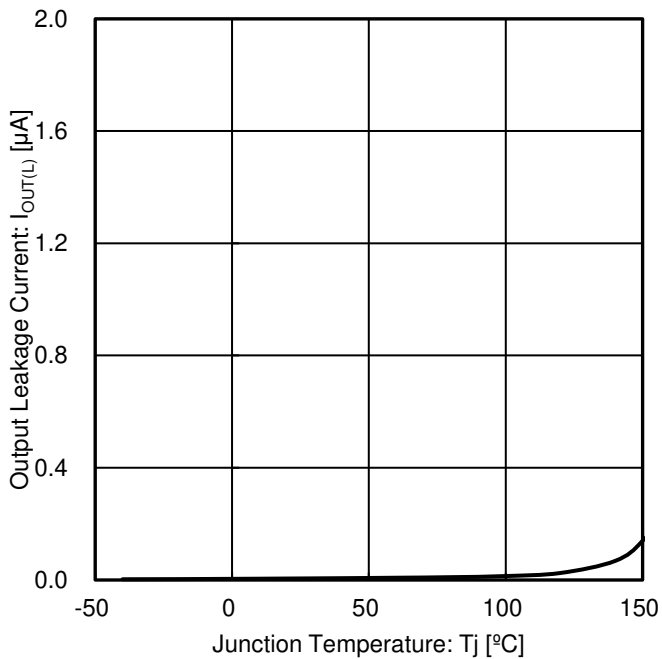

Figure 22. Output Leakage Current vs Junction Temperature

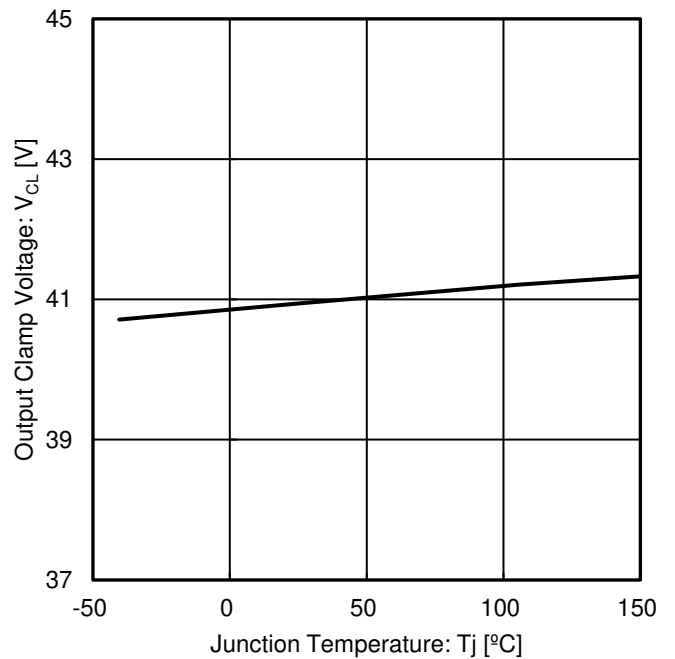

Figure 23. Output Clamp Voltage vs Junction Temperature

Typical Performance Curves – continued

(Reference data) (Unless otherwise specified, $V_{DD} = 5\text{ V}$, $T_j = 25\text{ }^\circ\text{C}$)

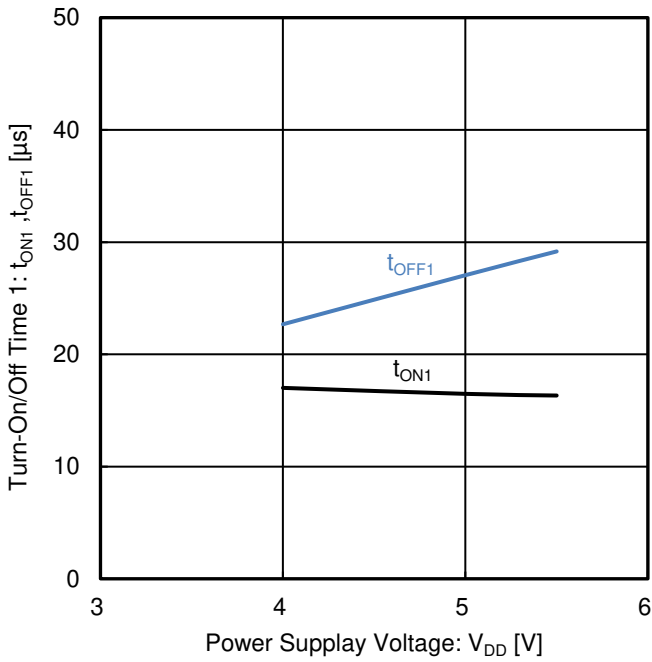

Figure 24. Turn-On/Off Time 1 vs Power Supply Voltage

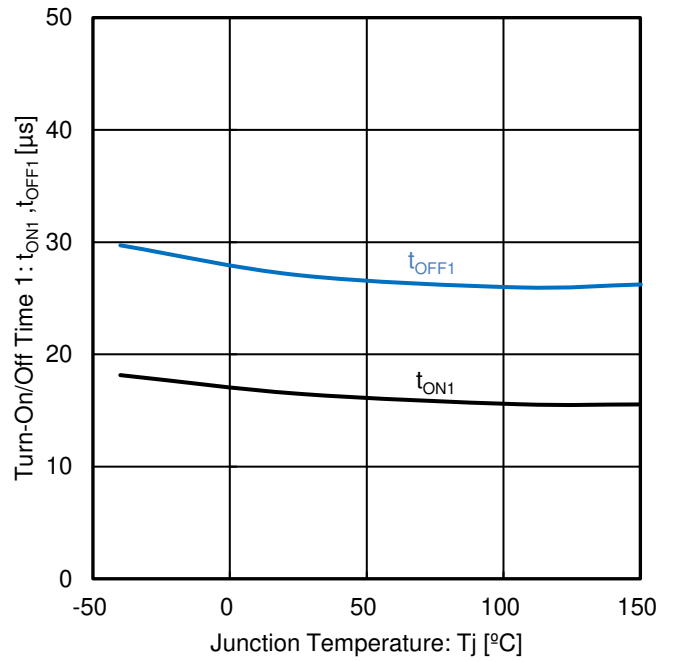

Figure 25. Turn-On/Off Time 1 vs Junction Temperature

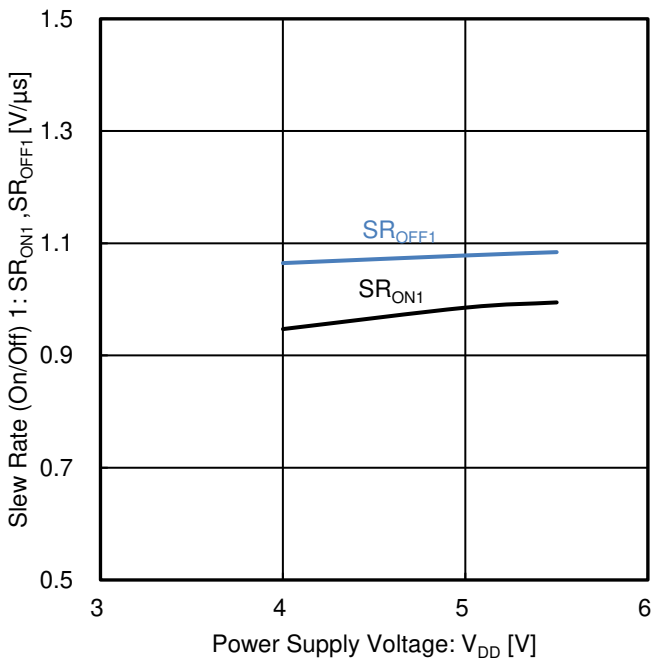

Figure 26. Slew Rate (On/Off) 1 vs Power Supply Voltage

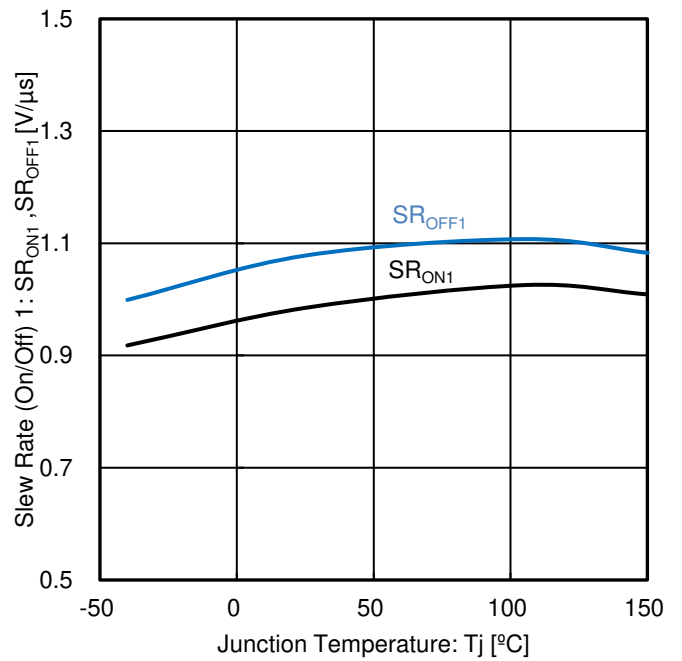

Figure 27. Slew Rate (On/Off) 1 vs Junction Temperature

Typical Performance Curves – continued

(Reference data) (Unless otherwise specified, $V_{DD} = 5\text{ V}$, $T_j = 25\text{ }^\circ\text{C}$)

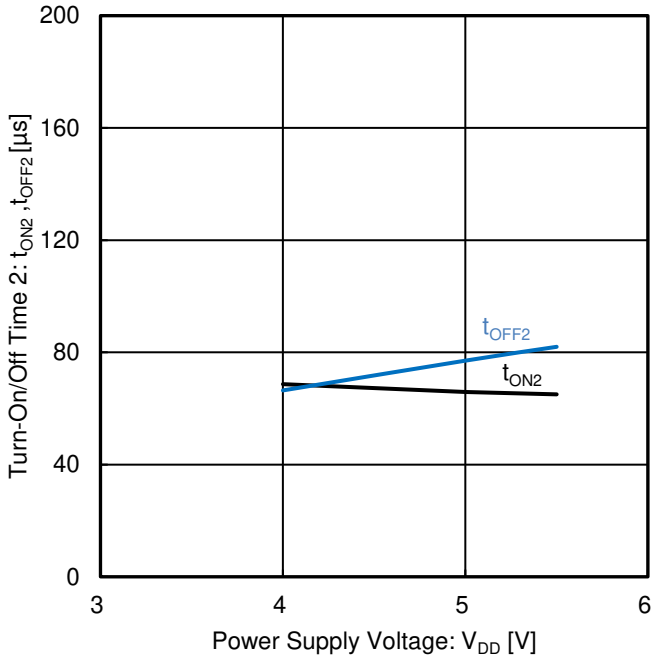

Figure 28. Turn-On/Off Time 2 vs Power Supply Voltage

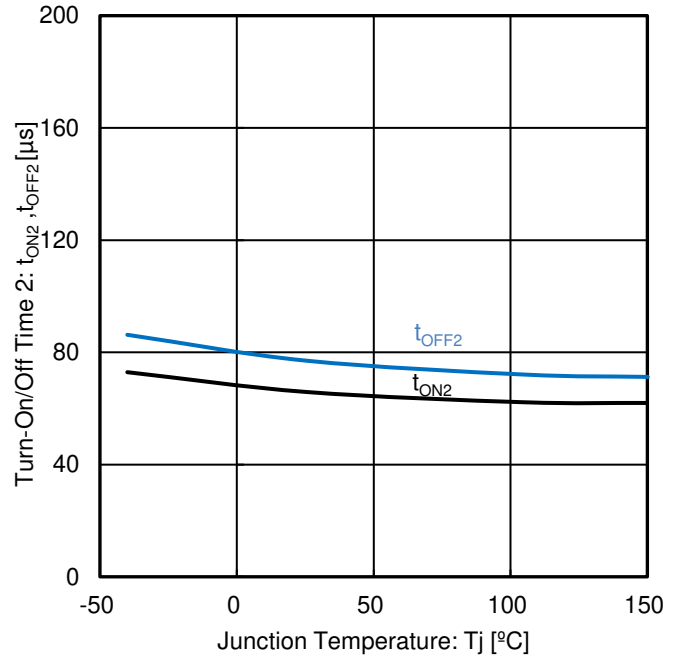

Figure 29. Turn-On/Off Time 2 vs Junction Temperature

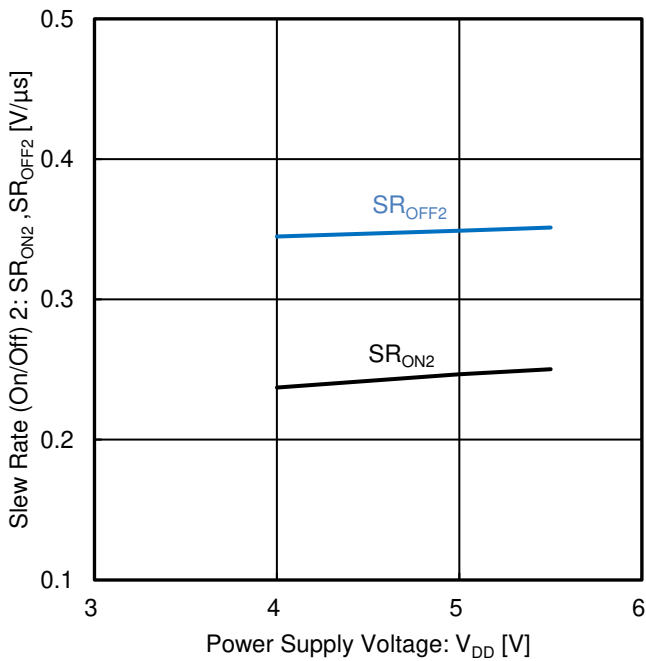

Figure 30. Slew Rate (On/Off) 2 vs Power Supply Voltage

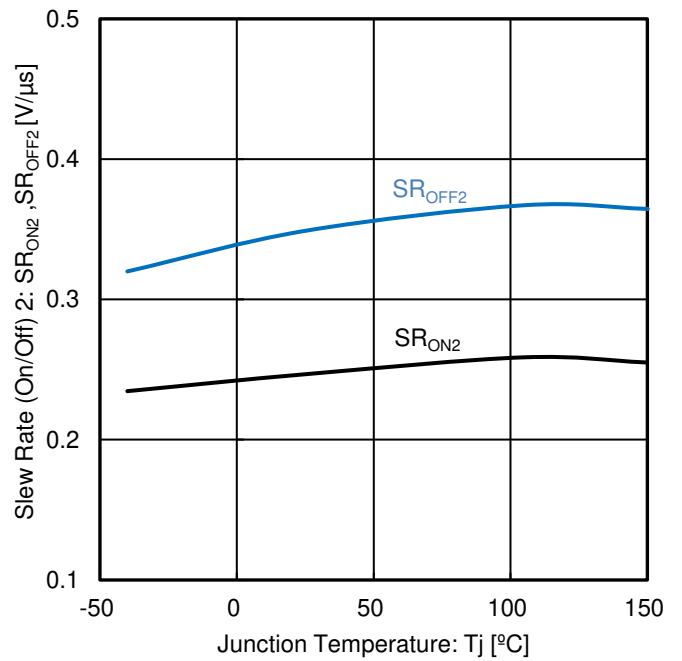

Figure 31. Slew Rate (On/Off) 2 vs Junction Temperature

Typical Performance Curves – continued

(Reference data) (Unless otherwise specified, $V_{DD} = 5\text{ V}$, $T_j = 25\text{ }^\circ\text{C}$)

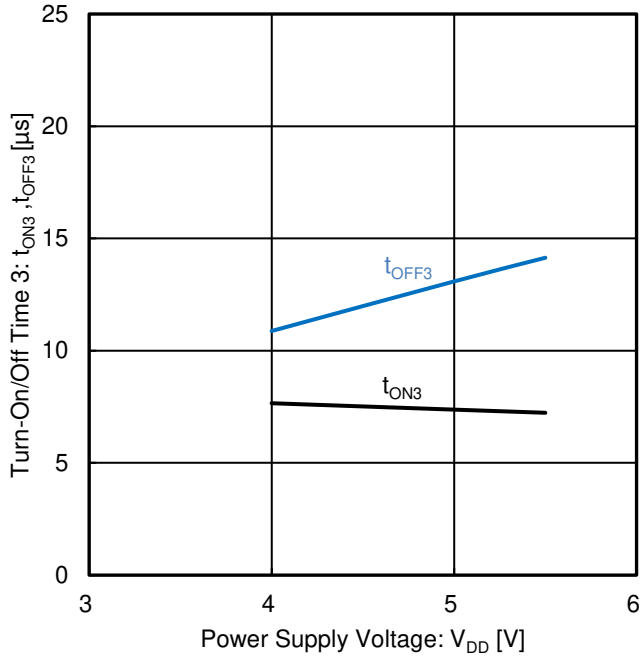

Figure 32. Turn-On/Off Time 3 vs Power Supply Voltage

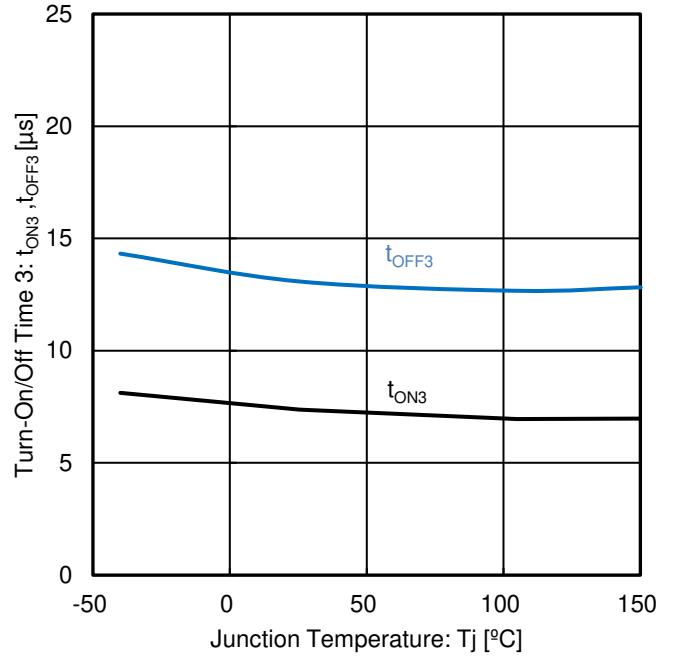

Figure 33. Turn-On/Off Time 3 vs Junction Temperature

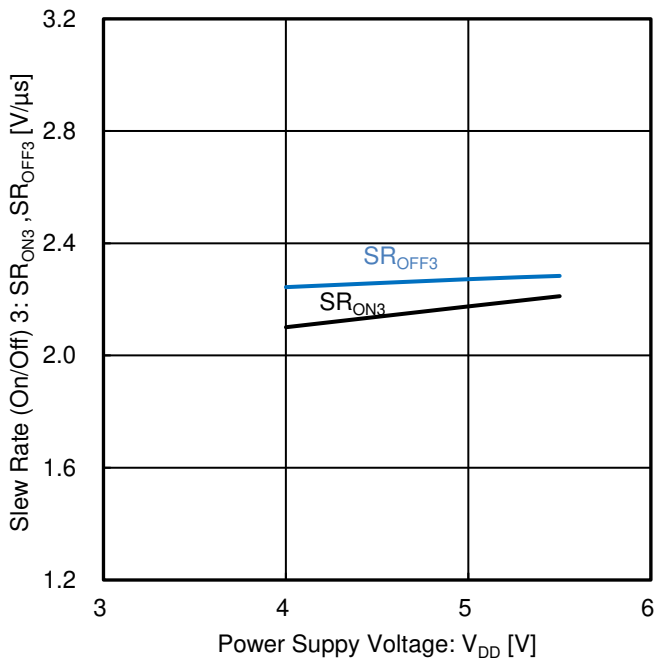

Figure 34. Slew Rate (On/Off) 3 vs Power Supply Voltage

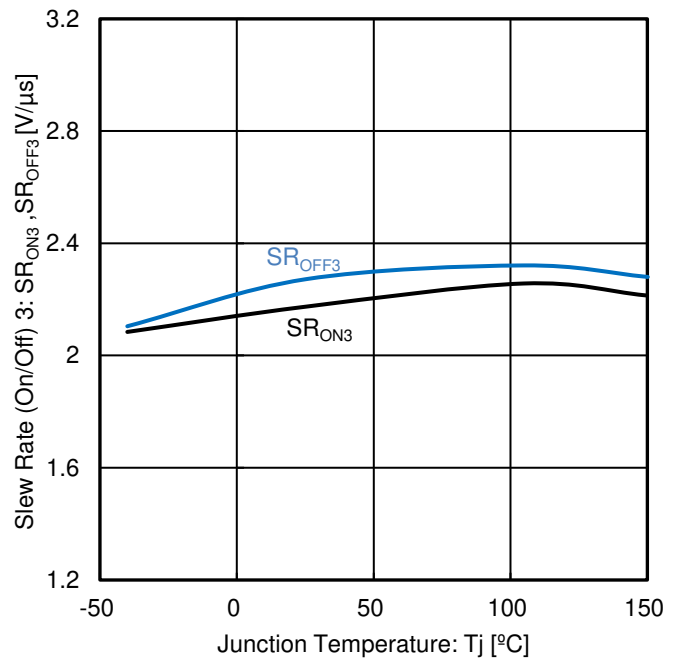

Figure 35. Slew Rate (On/Off) 3 vs Junction Temperature

Typical Performance Curves – continued

(Reference data) (Unless otherwise specified, $V_{DD} = 5\text{ V}$, $T_j = 25\text{ }^\circ\text{C}$)

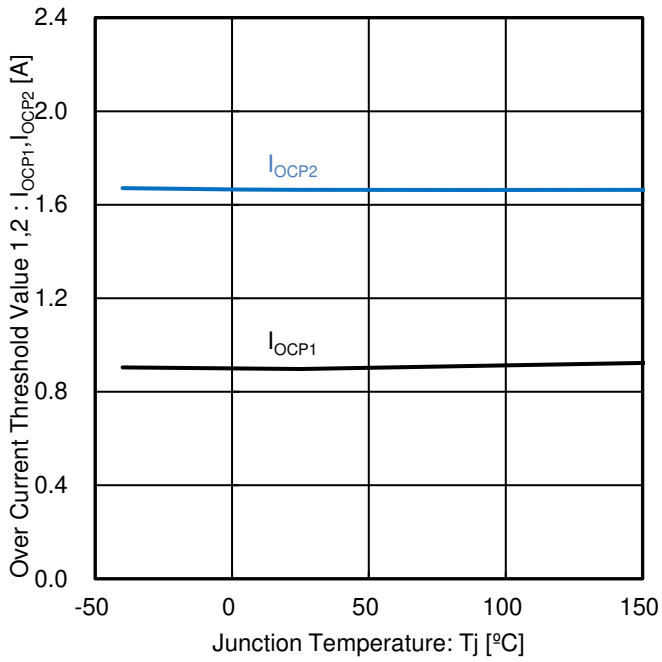

Figure 36. Over Current Threshold Value 1,2 vs Junction Temperature

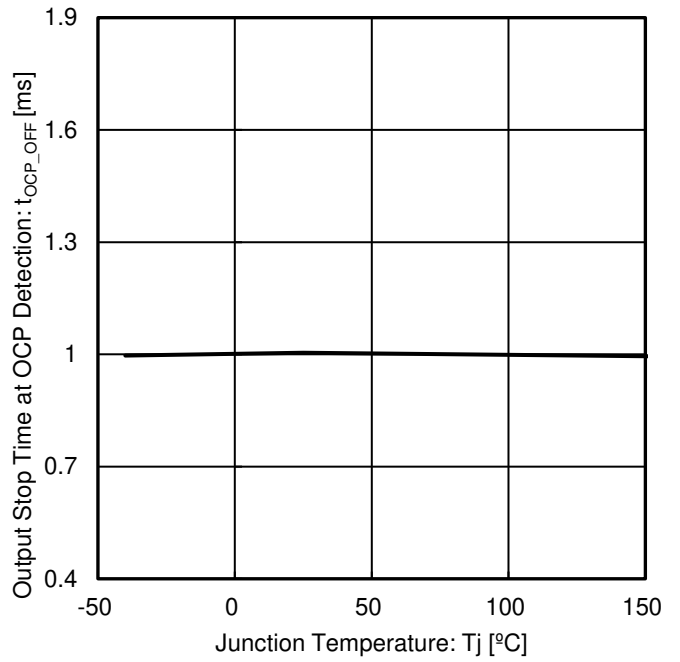

Figure 37. Output Stop Time at OCP Detection vs Junction Temperature

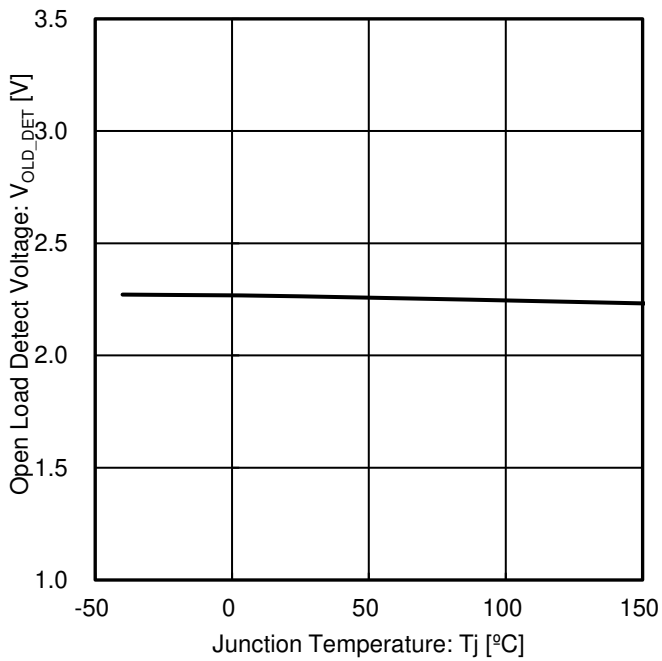

Figure 38. Open Load Detect Voltage vs Junction Temperature

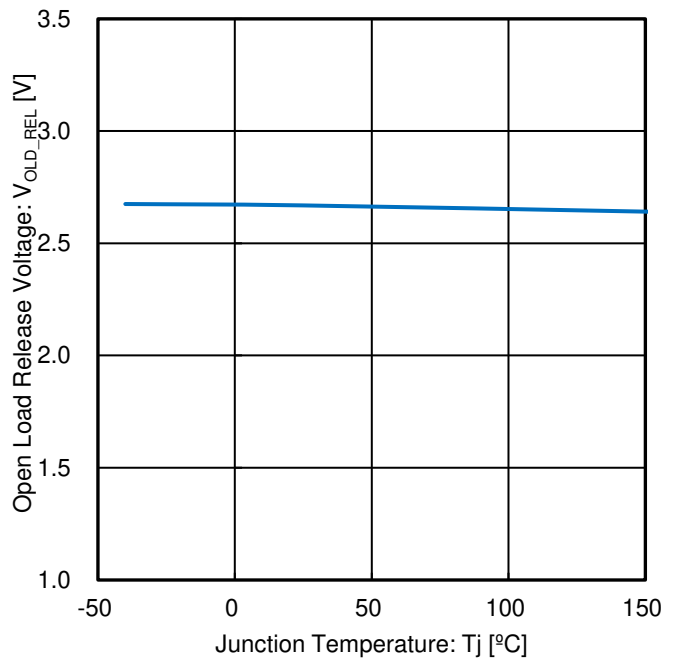

Figure 39. Open Load Release Voltage vs Junction Temperature

Typical Performance Curves – continued

(Reference data) (Unless otherwise specified, $V_{DD} = 5\text{ V}$, $T_j = 25\text{ }^\circ\text{C}$)

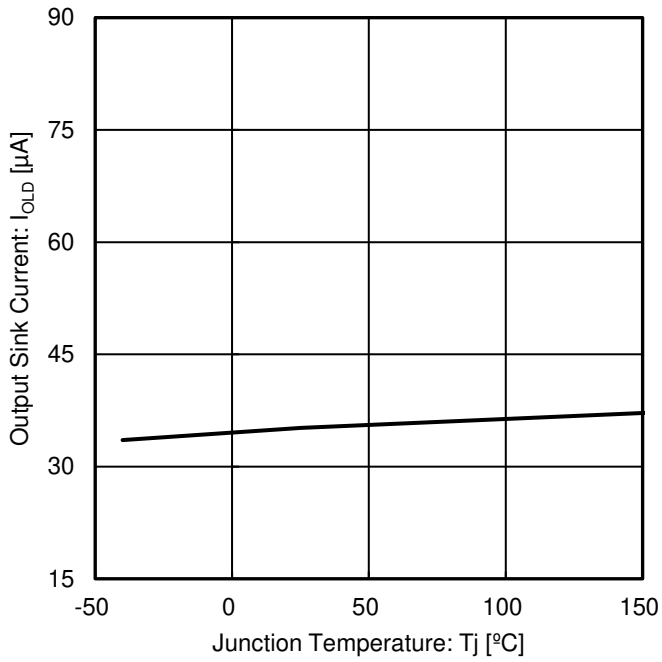

Figure 40. Output Sink Current vs Junction Temperature

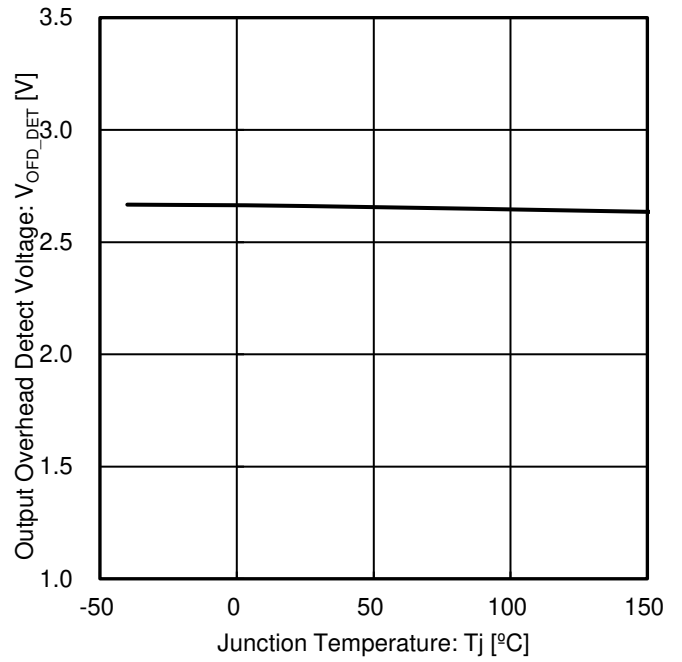

Figure 41. Output Overhead Detect Voltage vs Junction Temperature

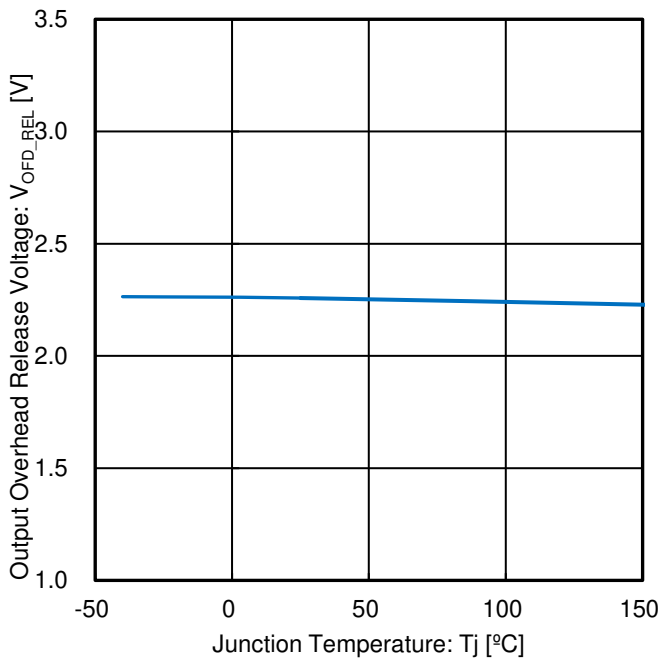

Figure 42. Output Overhead Release Voltage vs Junction Temperature

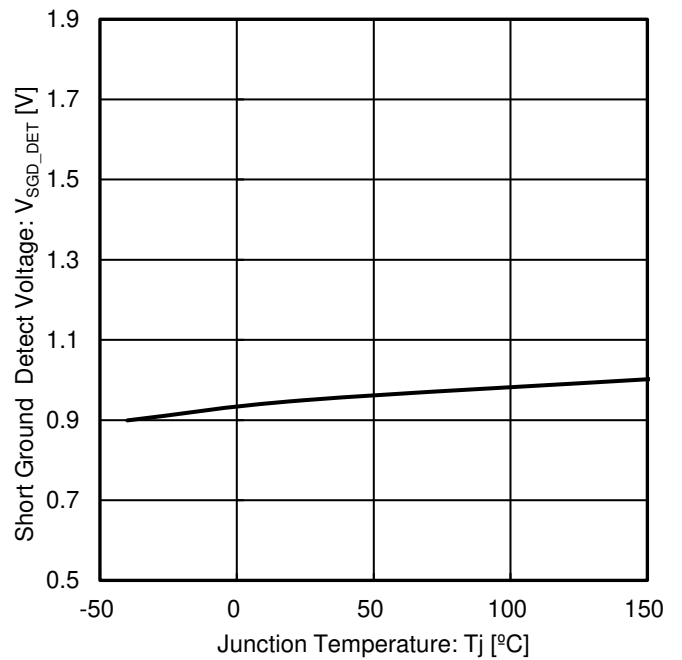

Figure 43. Short Ground Detect Voltage vs Junction Temperature

Typical Performance Curves – continued

(Reference data) (Unless otherwise specified, $V_{DD} = 5\text{ V}$, $T_j = 25\text{ }^\circ\text{C}$)

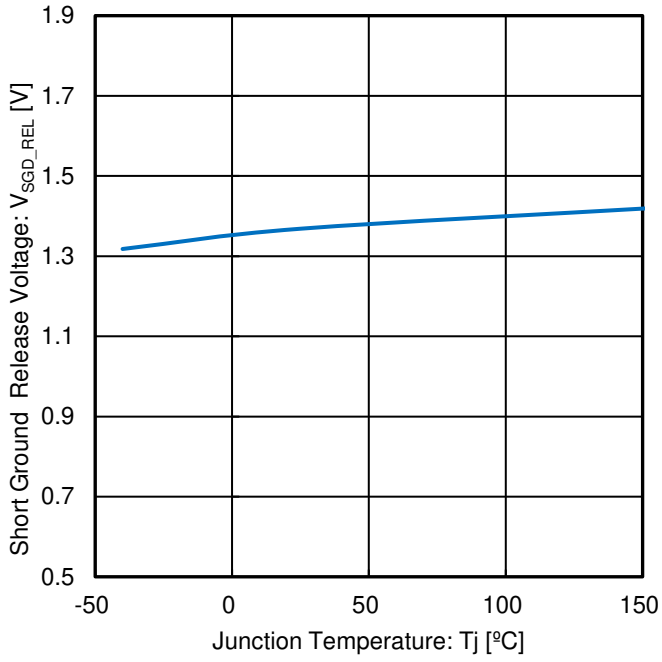

Figure 44. Short Ground Release Voltage vs Junction Temperature

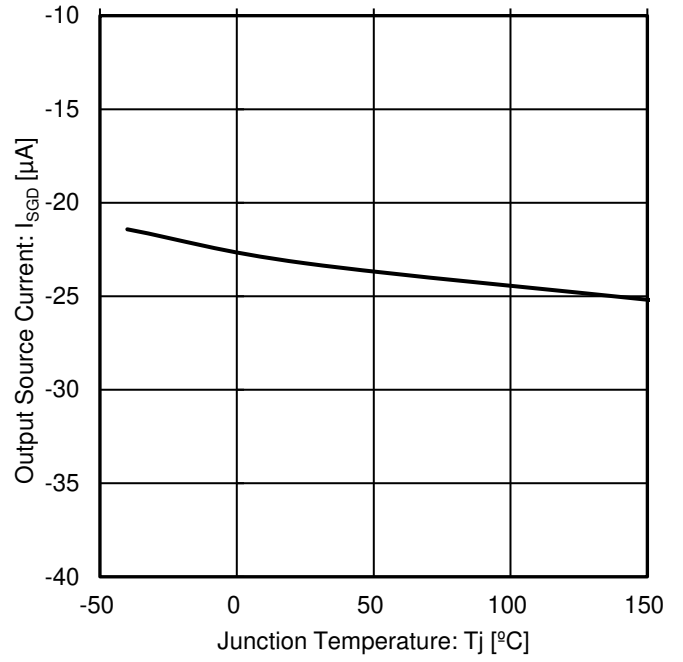

Figure 45. Output Source Current vs Junction Temperature

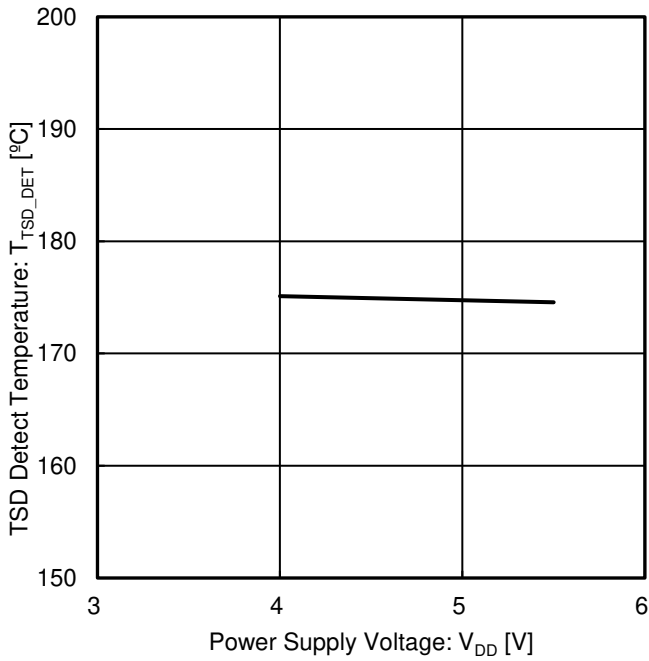

Figure 46. Thermal Shutdown Detect Temperature vs Power Supply Voltage

Measurement Circuit

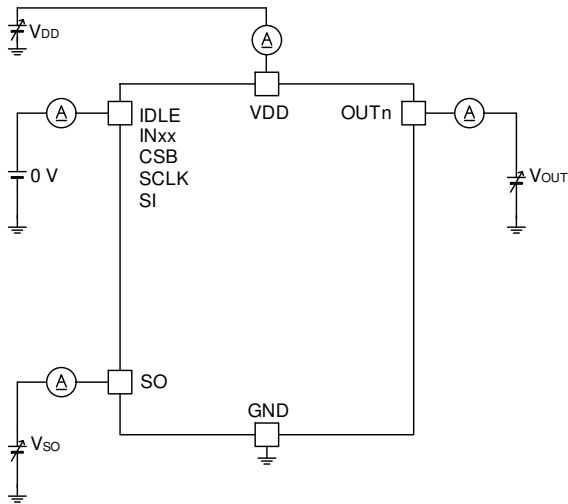

Figure 47. VDD Standby Current
 Low Level Input Current 1, 2
 Output Leakage Current
 Serial Out Output Leakage Current

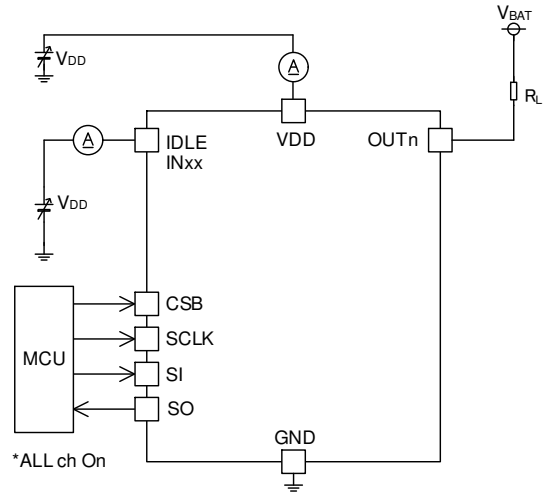

Figure 48. VDD Operating Current
 VDD Power On Reset Voltage
 Thermal Shutdown Detect Temperature
 Thermal Shutdown Hysteresis Temperature

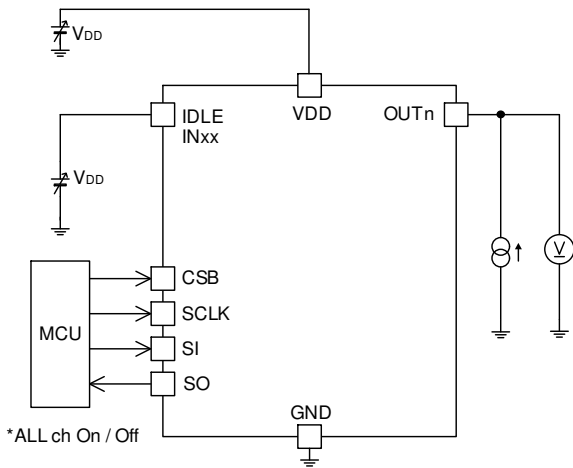

Figure 49. Output On Resistance
 Output Clamp Voltage

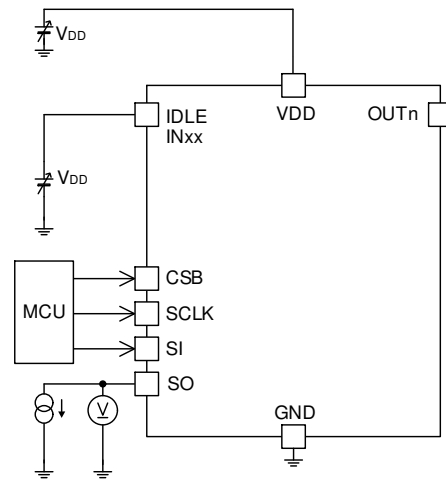

Figure 50. SO High/Low Level Output Voltage

Measurement Circuit – continued

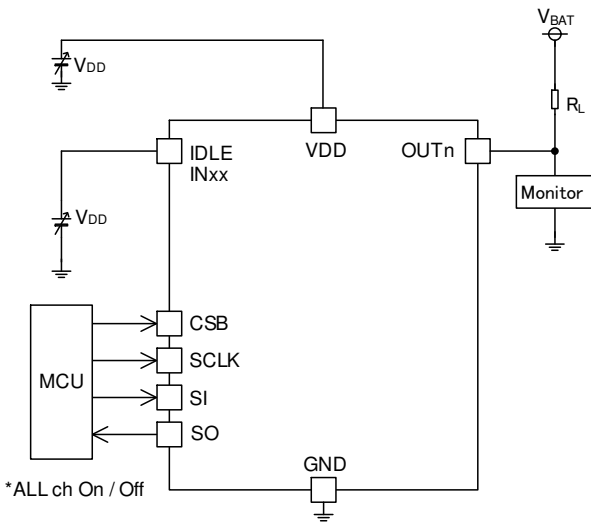

Figure 51. Slew Rate (On/Off) 1, 2, 3
Turn-On/Off Time 1, 2, 3

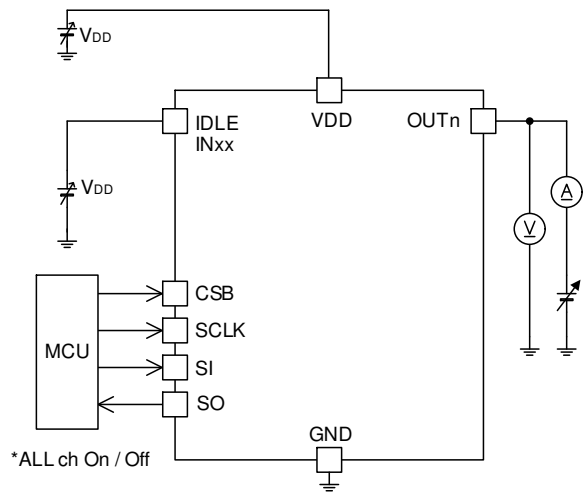

Figure 52. Open Load Detect/Release Voltage
Output Sink Current
Output Overhead Detect/Release Voltage
Short Ground Detect/Release Voltage
Output Source Current
Over Current Threshold Value 1, 2
Output Stop Time at OCP Detection

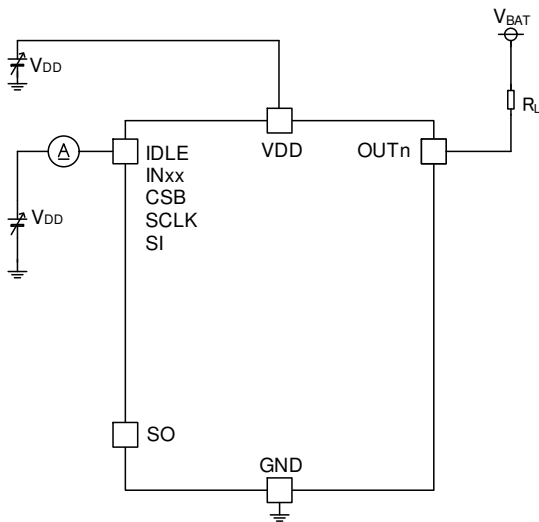
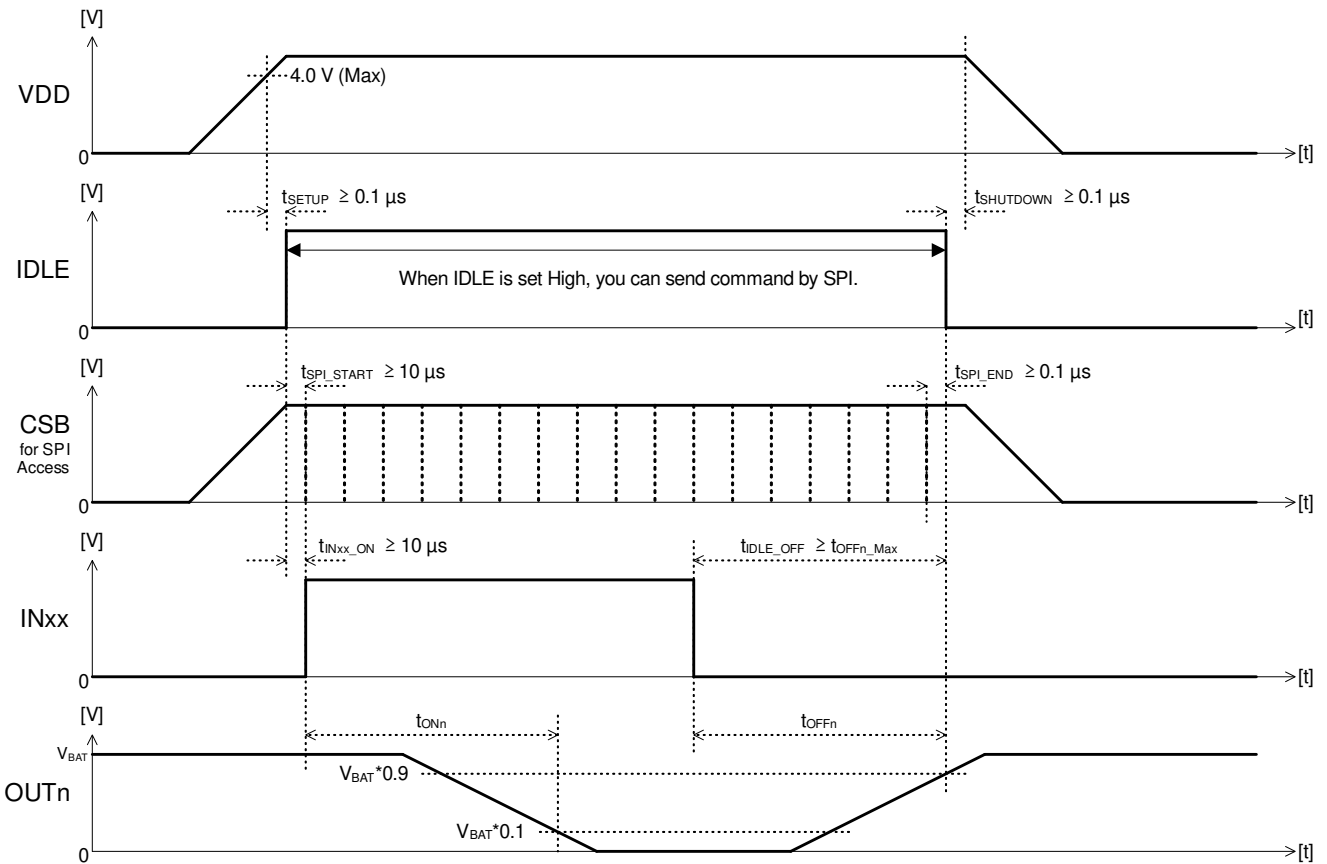

Figure 53. Low Level Input Voltage
High Level Input Voltage
Input Hysteresis Voltage
High Level Input Current 1, 2

Timing Chart

The following shows the sequence when H is input to the IDLE pin after the power is supplied.
 "xx" denotes each input (21, 43, 65, 87), and n denotes the channel number.



(Supplement) About Each Symbol

t_{SETUP}: Time from VDD reaches operating voltage until H can be input to IDLE.

t_{SPI_START}: Time from H is input to IDLE until SPI communication is available.

t_{INxx_ON}: Time from H is input to IDLE until control by INxx is available.

t_{SPI_END}: Time from completion of SPI communication until L is input L to IDLE ^(Note 1).

t_{IDLE_OFF}: Time from end of control by INxx until input L to IDLE.

t_{ONn}: Turn-On time

t_{OFFn}: Turn-Off time

t_{OFFn_Max}: Turn-Off Time (Max)

t_{SHUTDOWN}: Time from input L to IDLE until VDD is turned off.

(Note 1) If using SPI control to turn off low side SW, wait t_{IDLE_OFF} before inputting L to IDLE.

Timing Chart – continued

The following shows the sequence when the VDD and IDLE pins are simultaneously turned on/off. “xx” denotes each input (21, 43, 65, 87), and n denotes the channel number.

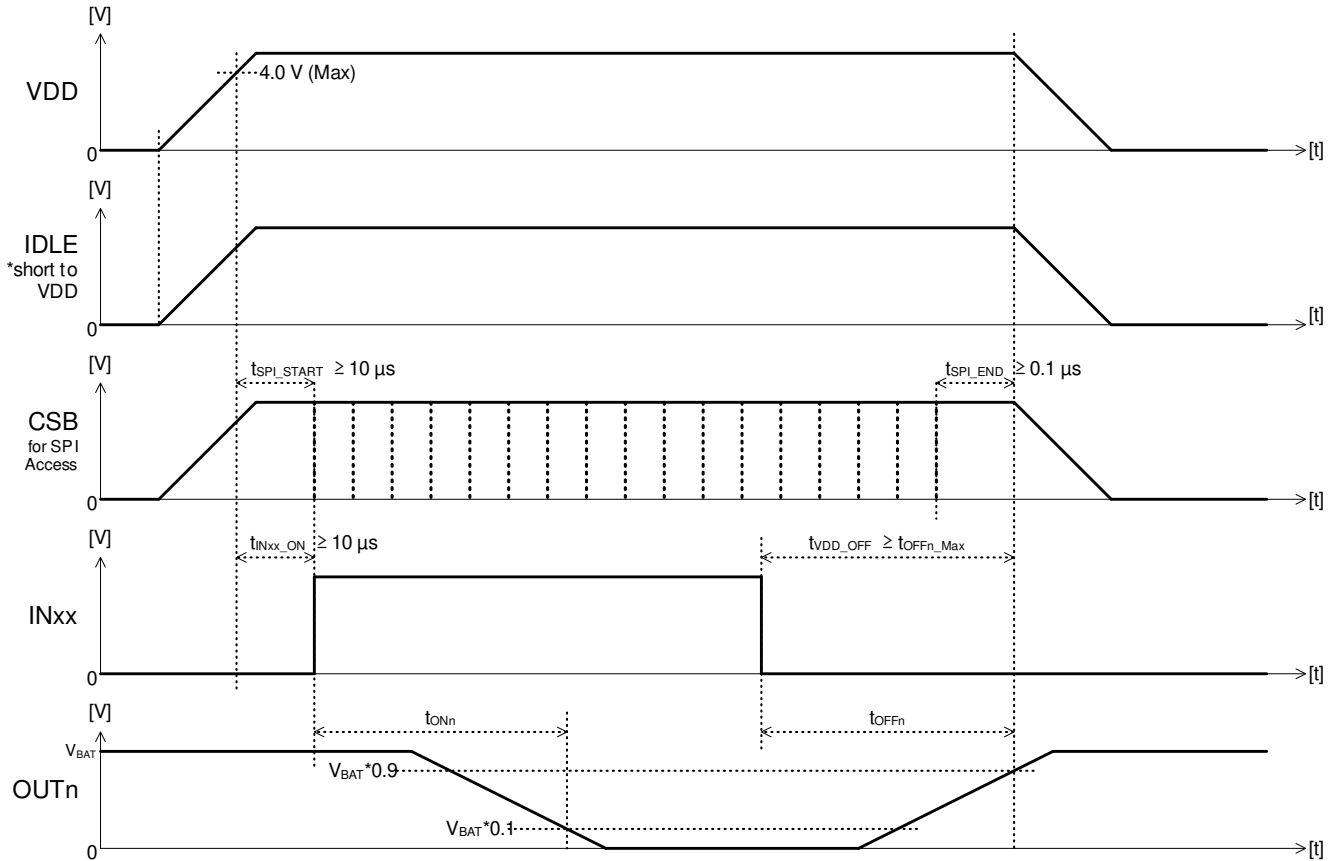

(Supplement) About Each Symbol

- t_{SPI_START} : Time from H is input to IDLE until SPI communication is available.
- t_{INxx_ON} : Time from VDD reaches operating voltage until control by INxx is available.
- t_{SPI_END} : Time from completion of SPI communication until lowering VDD ^(Note 1).
- t_{VDD_OFF} : Time from end of control by INxx until lowering VDD.

- t_{ONn} : Turn-On time
- t_{OFFn} : Turn-Off time
- t_{OFFn_Max} : Turn-Off time (Max)
- ^(Note 1) If using SPI control to turn off low side SW, wait t_{VDD_OFF} before lowering VDD.

Inductive Load Operation

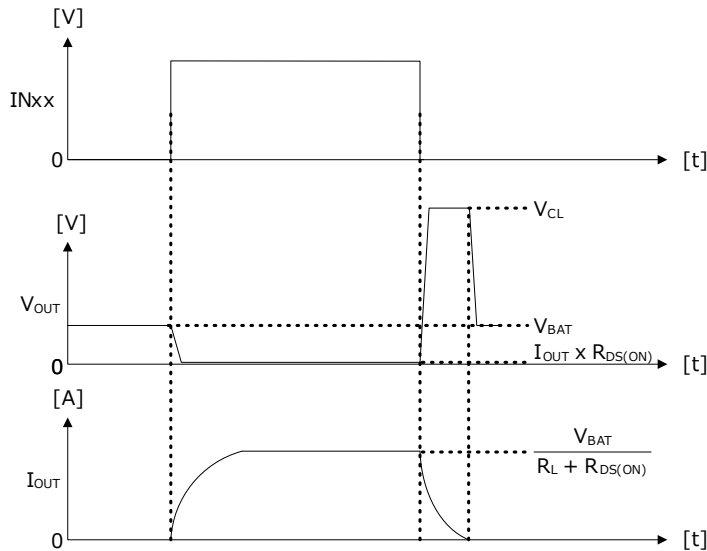

Synchro Mode

Two adjacent output pins can be connected in parallel. Parallel connection is available by combining OUT1/OUT2, OUT3/OUT4, OUT5/OUT6, OUT7/OUT8. The synchro mode can be set by SPI. For details, refer to "Register Map".

When controlling by IN21/IN43/IN65/IN87, channels connected in parallel are driven simultaneously.

All control by SPI is set from the odd number channel, and the even number channel setting is ignored. For example, to turn on OUT1/OUT2, write "1" to OUTCTRL1 bit of OUTCTRL register. Writing to OUTCTRL2 bit is ignored.

Over current protection and thermal shutdown is active on each channel connected in parallel, and both channels are turned off when protection is detected in either channel.

The detection of protection can be read from SPI by accessing DIAG_OUT4321 or DIAG_OUT8765 registers.

The error flag is output from the odd number channel and the error flag of the even number channel is fixed to "0". For example, if over current protection is detected in OUT1/OUT2, "1" is output from DIAG_OCP1 bit of DIAG_OUT4321 register, and DIAG_OCP2 bit outputs "0".

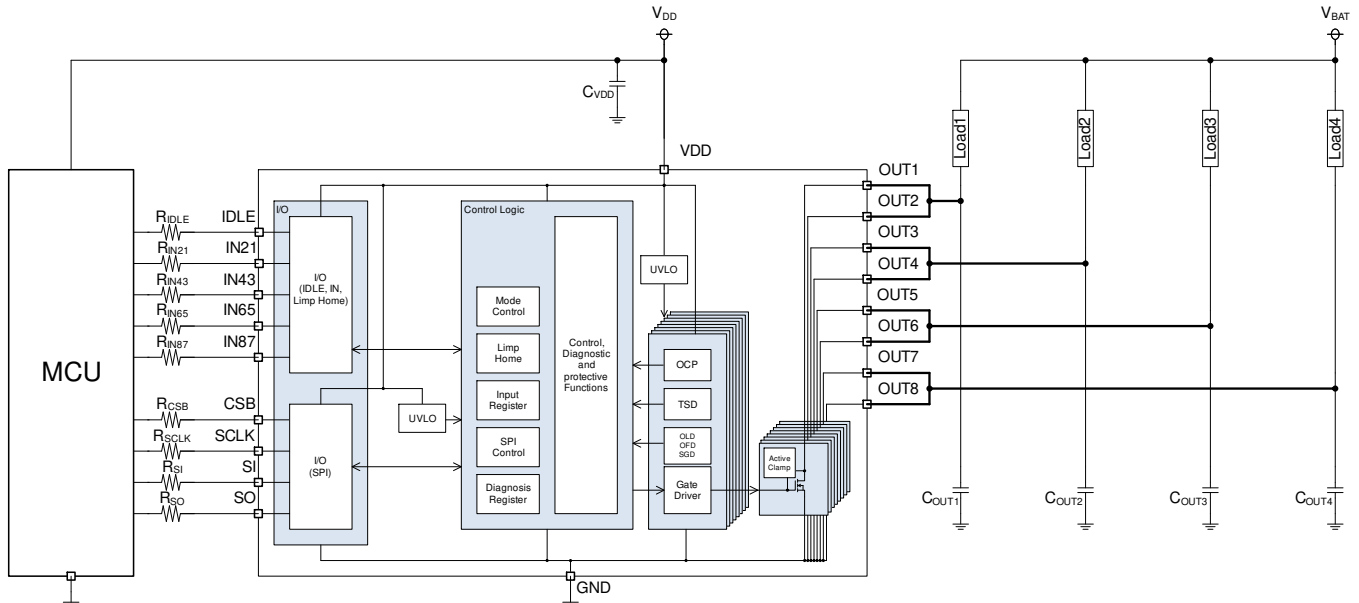

Caution: Differences in wire impedance between two neighboring outputs may affect characteristics such as turn-On/Off, slew rate, over current threshold value, and active clamp energy. To avoid this, it is recommended to short output pin with near the IC as possible.

Limp Home Mode

When IDLE is set to L, the IC enters Limp Home mode. This mode enables operation with low current consumption. Control by SPI is not possible in this mode, but on/off control by IN21/IN43/IN65/IN87 is available. Controllable channels are limited to odd number channels (1ch, 3ch, 5ch, 7ch). When IDLE becomes L, the register is cleared and returns to the default setting. The timing chart in Limp Home mode is shown below.

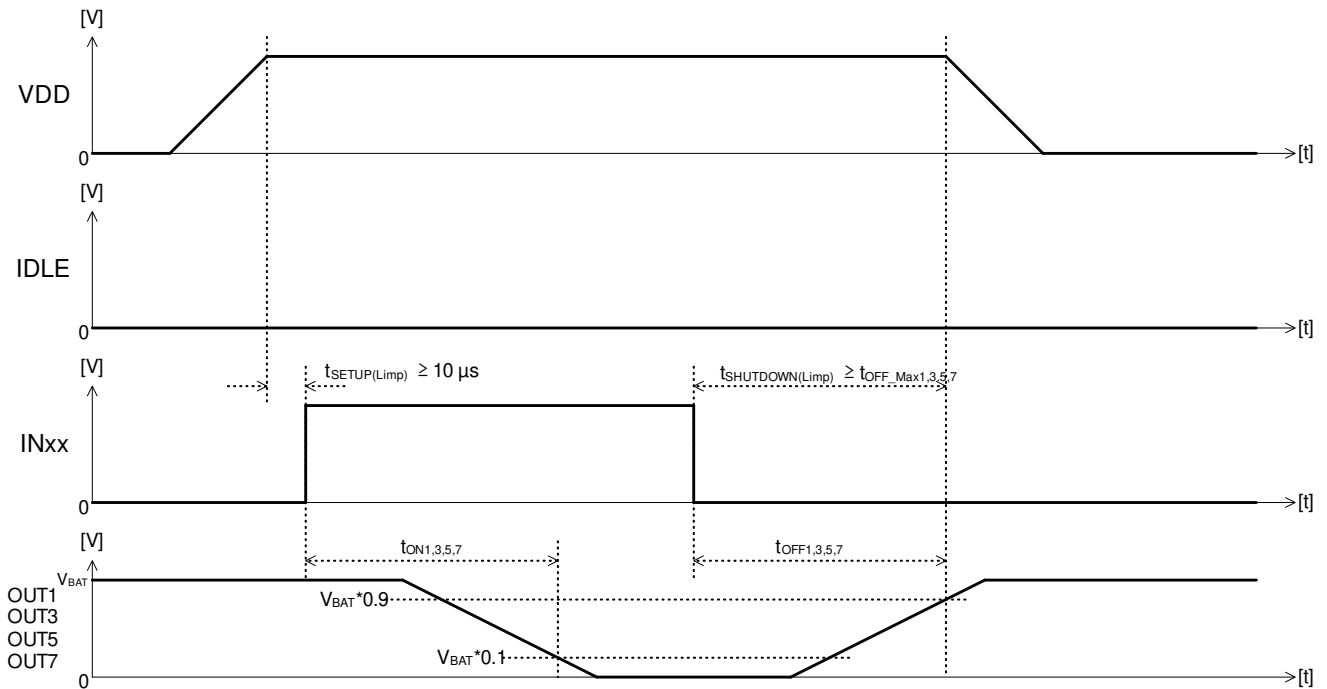

(Supplement) About Each Symbol

$t_{SETUP(Limp)}$: Time from VDD reaches operating voltage until control by INxx is available.

$t_{ON1,3,5,7}$: Turn-On time

$t_{OFF1,3,5,7}$: Turn-Off time

$t_{OFF_Max1,3,5,7}$: Turn-Off time (Max)

$t_{SHUTDOWN(Limp)}$: Time from all INxx is set to L until VDD is turned off.

SPI Specification

SPI overview

When CSB = H

SO is High-Z.

When CSB = L

Outputs to SO at the rising edge of SCLK.

SI is loaded into the register at the falling edge of SCLK.

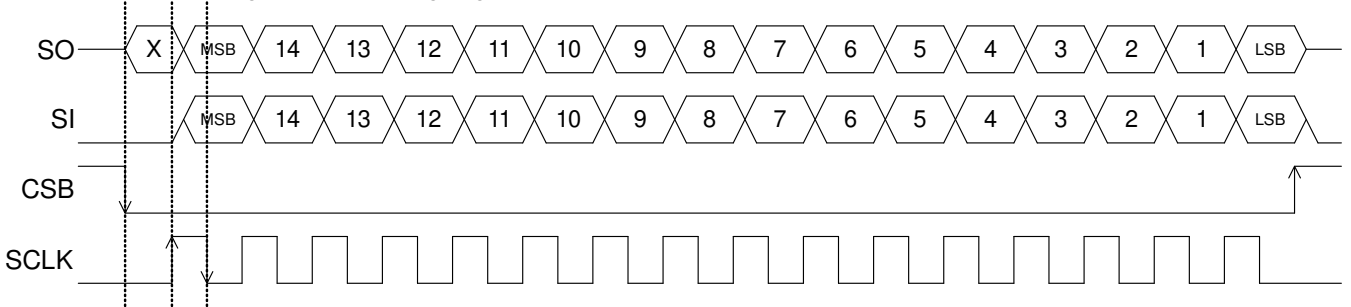

SPI protocol

The SO response to SPI access is returned at the next SPI access as shown in the following figure.

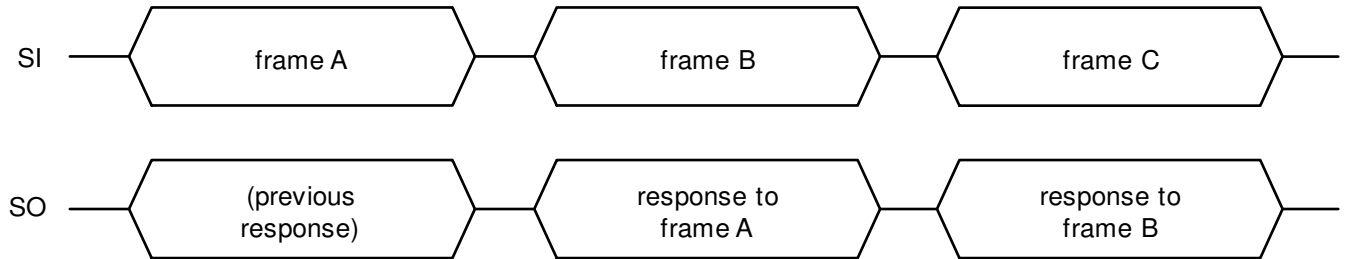

·Response when accessing with RE = 0 and with RE = 1

When accessing with RE = 0, respond "Standard diagnostic".

When accessing with RE = 1, respond the value of the specified register.

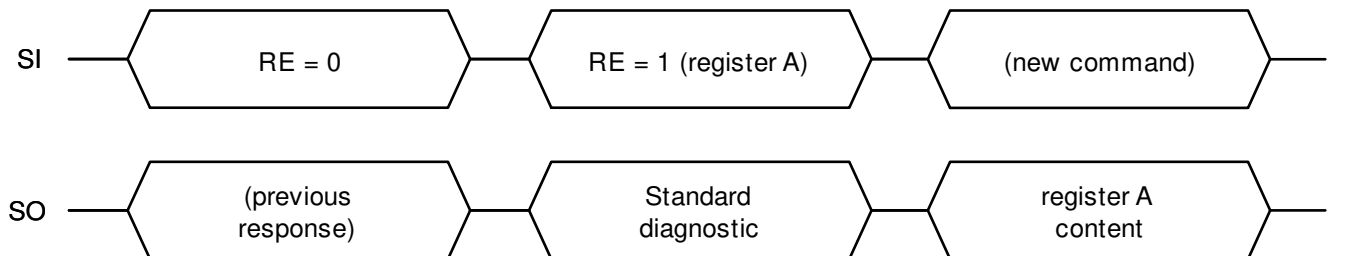

SPI Specification – continued

Serial Daisy Chain

Multiple devices can be connected in series as shown below.

For CSB signal and SCLK signal, connect a common signal. About SI / SO line, SO of Device 1 can be connected to SI of Device 2 as shown below.

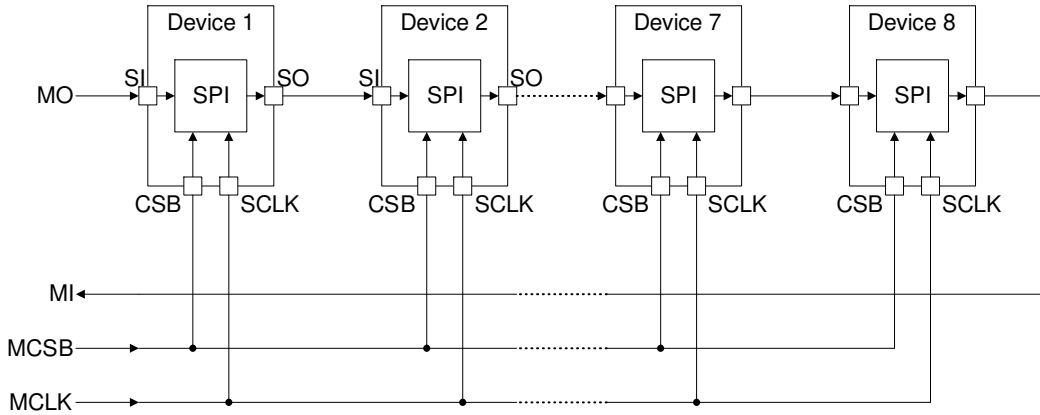

The timing chart when eight devices are connected is shown below.

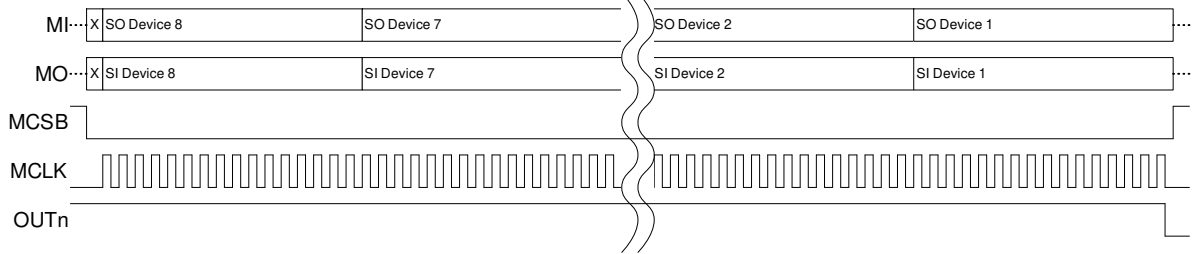

Parallel Connection

Multiple devices can be connected in parallel as shown below.

For SI signal, SCLK signal, and SO signal, connect a common signal. Separate signals are required for the CSB signal for each device.

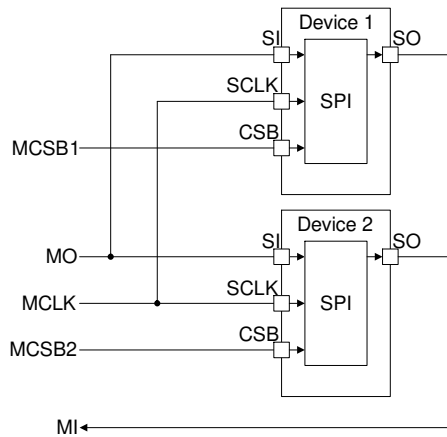

The timing chart when two devices are connected is shown below.

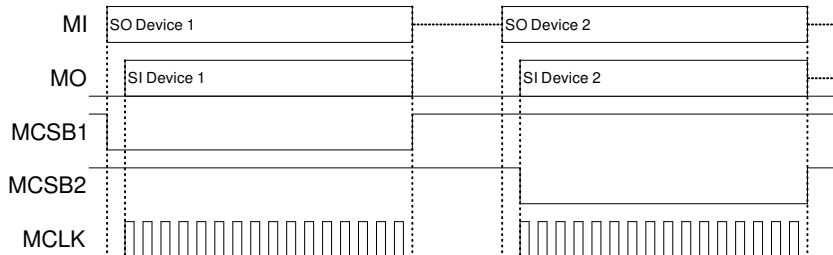

SPI Specification – continued

SPI Timing chart

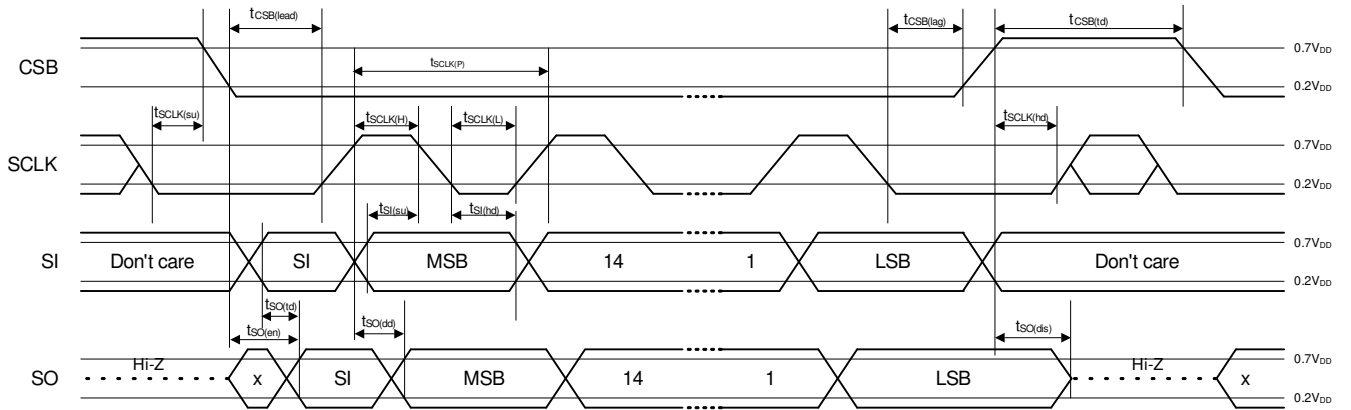

Parameter	Symbol	Min	Typ	Max	Unit
SCLK Frequency	f _{SCLK}	0	-	5	MHz
SCLK Period	t _{SCLK(P)}	200	-	-	ns
SCLK High Time	t _{SCLK(H)}	50	-	-	ns
SCLK Low Time	t _{SCLK(L)}	50	-	-	ns
SCLK Setup Time	t _{SCLK(su)}	50	-	-	ns
SCLK Hold Time	t _{SCLK(hd)}	50	-	-	ns
CSB Lead Time	t _{CSB(lead)}	250	-	-	ns
CSB Lag Time	t _{CSB(lag)}	250	-	-	ns
Transfer Delay Time	t _{CSB(td)}	250	-	-	ns
Data Setup Time	t _{SI(su)}	20	-	-	ns
Data Hold Time	t _{SI(hd)}	20	-	-	ns
SPI Output Enable Time ^(Note 1)	t _{SO(en)}	-	-	200	ns
SPI Output Disable Time ^(Note 1)	t _{SO(dis)}	-	-	250	ns
SPI Output Data Delay Time ^{(Note 1)(Note 2)}	t _{SO(dd)}	-	-	100	ns
ERR Output Through Delay Time ^(Note 1)	t _{SO(td)}	-	-	200	ns

(Note 1) Not 100 % tested.

(Note 2) SO capacitance = 20 pF

SPI Specification – continued

SI data structure

Bit[15]	Bit[14]	Bit[13]	Bit[12]	Bit[11]	Bit[10]	Bit[9]	Bit[8]	Bit[7]	Bit[6]	Bit[5]	Bit[4]	Bit[3]	Bit[2]	Bit[1]	Bit[0]
RE	WE	Address					TEST	Data							

RE

0: SO outputs "Standard diagnostic" at the next SPI access.

1: SO outputs the register specified by Address at the next SPI access.

WE

0: Not Write.

1: Write.

TEST

Be sure to set 0.

Data

When WE = 1, various settings are enabled by writing '0' or '1' to Data.

For details, refer to "Register Map".

"Standard diagnostic" (when RE = 0 in the previous SPI access)

Initial Value 0x4000

Bit[15]	Bit[14]	Bit[13]	Bit[12]	Bit[11]	Bit[10]	Bit[9]	Bit[8]	Bit[7]	Bit[6]	Bit[5]	Bit[4]	Bit[3]	Bit[2]	Bit[1]	Bit[0]
0	INIT	0	0	0	TER	0	0	ERR8	ERR7	ERR6	ERR5	ERR4	ERR3	ERR2	ERR1

INIT

0: Normal (after power on or IDLE = 'L'-'>'H', from the second time SPI access).

1: After power on or IDLE = 'L'-'>'H', first time SPI access.

TER

0: Normal

1: SPI communication error

When High pulse input of SCLK is other than (16 times + 8 x m, m is an integer 0 or above) in the low level section of CSB, a communication error is judged.

ERRn (n is the channel number)

0: Normal

1: The value is latched and output when over current protection or thermal shutdown of the corresponding channel is detected.

This bit is cleared by reading DIAG register (DIAG_OUT4321 or DIAG_OUT8765) of the channel on which protection is detected.

SO output data structure (when RE = 1 in the previous SPI access)

Bit[15]	Bit[14]	Bit[13]	Bit[12]	Bit[11]	Bit[10]	Bit[9]	Bit[8]	Bit[7]	Bit[6]	Bit[5]	Bit[4]	Bit[3]	Bit[2]	Bit[1]	Bit[0]
1	WE	Address					ERR _{ALL}	Data							

WE, Address

Outputs WE and Address values that were set during the previous SPI access.

ERR_{ALL}

Outputs 1 when either over current protection or thermal shutdown of OUT is detected on at least one channel.

Data

Outputs the register value of Address that were set during the previous SPI access.

Register Map

Register Name	Register Access	Address	TEST	Data								Initial
				Bit[13:9]	Bit[8]	Bit[7]	Bit[6]	Bit[5]	Bit[4]	Bit[3]	Bit[2]	
OUTCTRL	R/W	0x00	0	OUTCTRL8	OUTCTRL7	OUTCTRL6	OUTCTRL5	OUTCTRL4	OUTCTRL3	OUTCTRL2	OUTCTRL1	0x00
SRCTRL0	R/W	0x01	0	SRCTRL4[1:0]		SRCTRL3[1:0]		SRCTRL2[1:0]		SRCTRL1[1:0]		0x00
SRCTRL1	R/W	0x02	0	SRCTRL8[1:0]		SRCTRL7[1:0]		SRCTRL6[1:0]		SRCTRL5[1:0]		0x00
OCPCTRL	R/W	0x03	0	OCPCTRL8	OCPCTRL7	OCPCTRL6	OCPCTRL5	OCPCTRL4	OCPCTRL3	OCPCTRL2	OCPCTRL1	0x00
DIRCTRL	R/W	0x04	0	DIRCTRL8	DIRCTRL7	DIRCTRL6	DIRCTRL5	DIRCTRL4	DIRCTRL3	DIRCTRL2	DIRCTRL1	0x55
SYNC	R/W	0x05	0	0	0	0	0	SYNC87	SYNC65	SYNC43	SYNC21	0x00
STATUS_IN	RO	0x06	0	0	0	0	0	STATUS_IN87	STATUS_IN65	STATUS_IN43	STATUS_IN21	0x00
DIAG_OLD/OFD	R/W	0x08	0	DIAG_OLD/OFD8	DIAG_OLD/OFD7	DIAG_OLD/OFD6	DIAG_OLD/OFD5	DIAG_OLD/OFD4	DIAG_OLD/OFD3	DIAG_OLD/OFD2	DIAG_OLD/OFD1	0x00
DIAG_SGD	R/W	0x09	0	DIAG_SGD8	DIAG_SGD7	DIAG_SGD6	DIAG_SGD5	DIAG_SGD4	DIAG_SGD3	DIAG_SGD2	DIAG_SGD1	0x00
DIAG_OUT4321	RO	0x0A	0	DIAG_OCP4	DIAG_TSD4	DIAG_OCP3	DIAG_TSD3	DIAG_OCP2	DIAG_TSD2	DIAG_OCP1	DIAG_TSD1	0x00
DIAG_OUT8765	RO	0x0B	0	DIAG_OCP8	DIAG_TSD8	DIAG_OCP7	DIAG_TSD7	DIAG_OCP6	DIAG_TSD6	DIAG_OCP5	DIAG_TSD5	0x00
HWCR	WO	0x0C	0	0	RST	0	0	0	0	0	0	0x00
T_TESTMODE	WO	0x1E	1	0	0	0	0	0	0	0	TESTMODE	0x00

Register Name	Register Access	Address	Explanation of Data
OUTCTRL	Read / Write	0x00h	OUTCTRLn bit (n represents the channel number) '0': OUTn off setting '1': OUTn on setting
SRCTRL0 SRCTRL1	Read / Write	0x01h 0x02h	SRCTRLn[1:0] bit '00': Slew Rate Setting 1.0 V/μs (Typ) '01': Slew Rate Setting 2.25 V/μs (Typ) '10': Slew Rate Setting 0.30 V/μs (Typ) '11': Same setting as '00'
OCPCTRL	Read / Write	0x03h	OCPCTRLn bit '0': Over Current Threshold Value 1 0.85 A (Typ) '1': Over Current Threshold Value 2 1.7 A (Typ)
DIRCTRL	Read / Write	0x04h	DIRCTRLn bit '0': IN control disabled '1': IN control enabled
SYNC	Read / Write	0x05h	SYNC21/SYNC43/SYNC65/SYNC87 bit '0': Synchro mode disabled '1': Synchro mode enabled
STATUS_IN	Read Only	0x06h	STATUS_IN87/STATUS_IN65/STATUS_IN43/STATUS_IN21 bit '0': IN87/IN65/IN43/IN21 L input '1': IN87/IN65/IN43/IN21 H input
DIAG_OLD/OFD	Read / Write	0x08h	DIAG_OLD/OFDn bit '0': OLD/OFD disabled '1': OLD/OFD enabled OLD is enabled when OUTn is off. OFD is enabled when OUTn is on. When SPI access is performed again, it automatically returns to '0' (disabled). Read OLD/OFD result by read access (RE = 1). When OLD is active, the judgement is made as below. '0': OLD detection '1': Normal When OFD is active, the judgement is made as below. '0': Normal '1': OFD detection For details, refer to " Open Load Detection " and " Output Overhead Fault Detection Function ".

Register Map – continued

Register Name	Register Access	Address	Explanation of Data
DIAG_SGD	Read / Write	0x09h	<p>DIAG_SGDn bit '0': SGD disabled '1': SGD enabled</p> <p>This function is used when OUTn is off. When SPI access is performed again, it automatically returns to '0' (disabled).</p> <p>Read SGD result by read access (RE = 1). '0': SGD detection '1': Normal</p> <p>For details, refer to "Short Ground Detection".</p>
DIAG_OUT4321	Read Only	0x0Ah	<p>Read the error flag of ch1/ch2/ch3/ch4. DIAG_TSDn bit '0': Normal '1': TSD detection</p> <p>DIAG_OCPn bit '0': Normal '1': OCP detection</p> <p>It automatically returns to '0' when DIAG_OUT4321 is accessed.</p>
DIAG_OUT8765	Read Only	0x0Bh	<p>Read the error flag of ch5/ch6/ch7/ch8. DIAG_TSDn bit '0': Normal '1': TSD detection</p> <p>DIAG_OCPn bit '0': Normal '1': OCP detection</p> <p>It automatically returns to '0' when DIAG_OUT8765 is accessed.</p>
HWCR	Write Only	0x0Ch	<p>RST '0': Normal '1': Hardware reset (auto clear)</p>
T_TESTMODE	Write Only	0x1Eh	<p>TESTMODE '0': Normal '1': Test Mode</p> <p>If IDLE is 5.6 V (Min) or more and "1" is written to this register, IC enters test mode. For this reason, do not access to this register.</p>

Over Current Protection Function

Turns off the output when an over current error occurs in the output (A in the figure). The output returns to on when the output stop time of 1 ms (Typ) has passed. However, if an over current error still continue at this time, the output will be turned off again (B in the figure). When an over current error is improved, the output recovers after the output stop time from over current error is lastly detected has passed (C in the figure).

If an over current error is detected, the internal over current detection flag outputs '1' (A' in the figure). This flag can be read from SPI read access or from Standard diagnostic. When the flag is read by SPI read access, it is cleared by the next SPI access after read access (D in the figure).

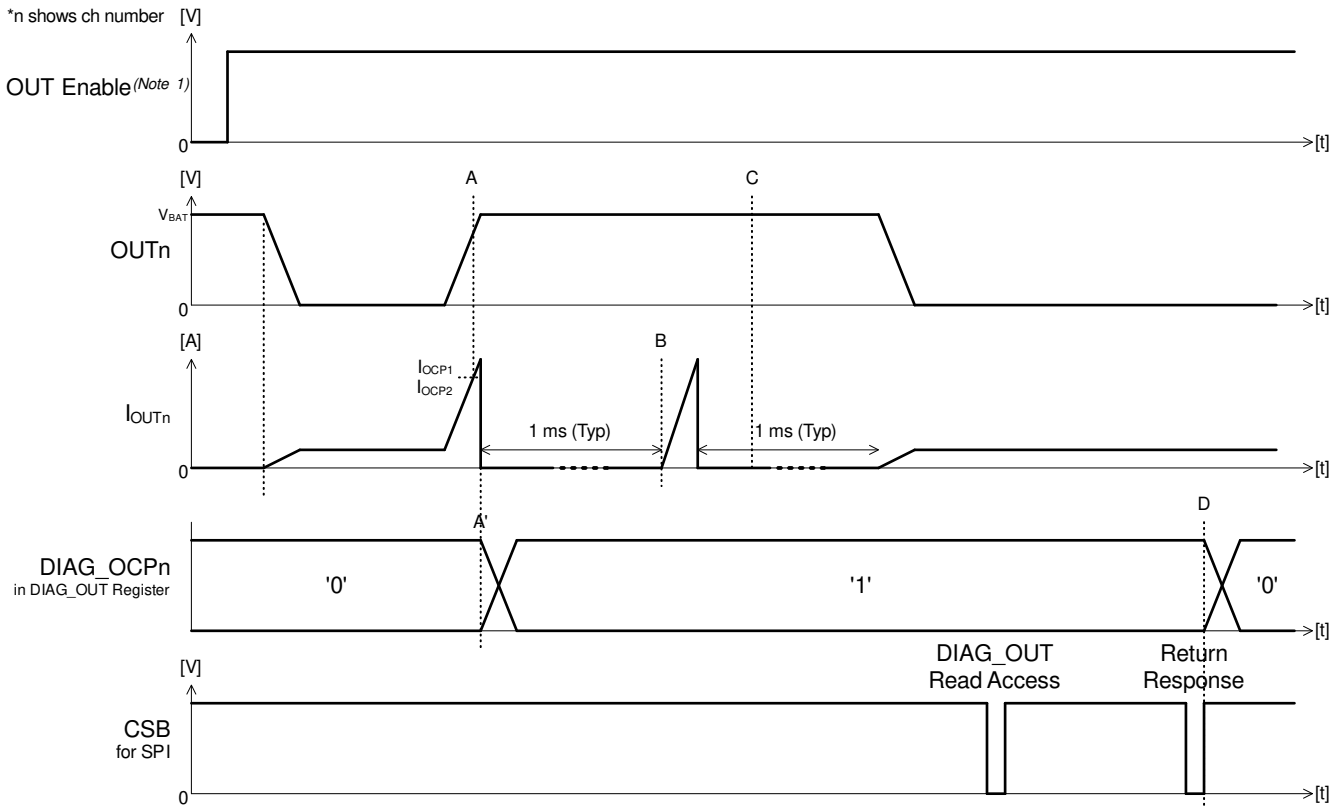

(Note 1) Output on/off control signal. This signal is controlled by IN87, IN65, IN43, IN21 or OUT_CTRL register.

When an over current error is detected in multiple channels, the output off time is measured starting from the channel that over current error was detected lastly.

For example, if an over current error is detected in ch2 after an over current error is detected in ch1 before the output off time of ch1 passes, the time t_{SHORT} from ch1 detects an error until an error is detected in ch2 will be added to the output off time of ch1.

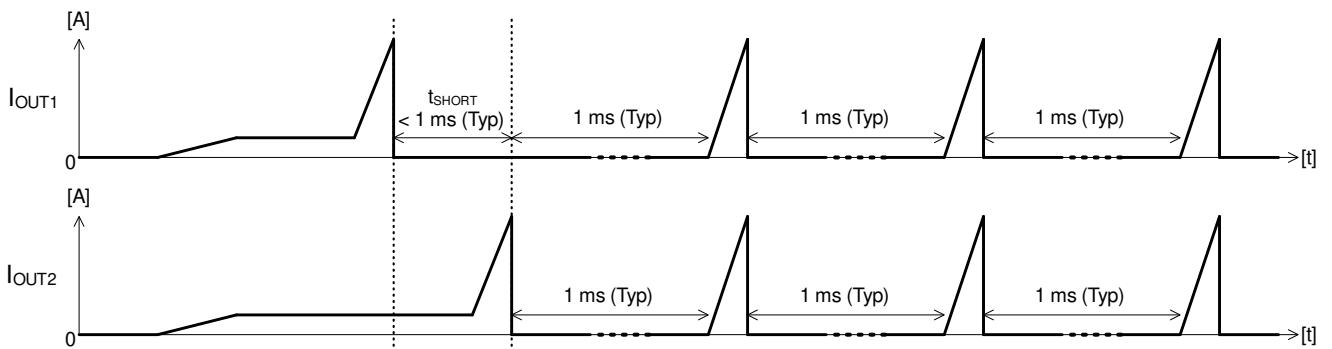

Thermal Shutdown Function

Turns off the output when the junction temperature rises 175 °C (Typ) or above (A in the figure). After that, the output automatically returns to on when the junction temperature falls 160 °C (Typ) or below (B in the figure).

When thermal shutdown is detected, the internal thermal shutdown flag outputs '1' (A in the figure). This flag can be read from SPI read access or Standard diagnostic. When the flag is read by SPI read access, it is cleared by the next SPI access after read access (C in the figure).

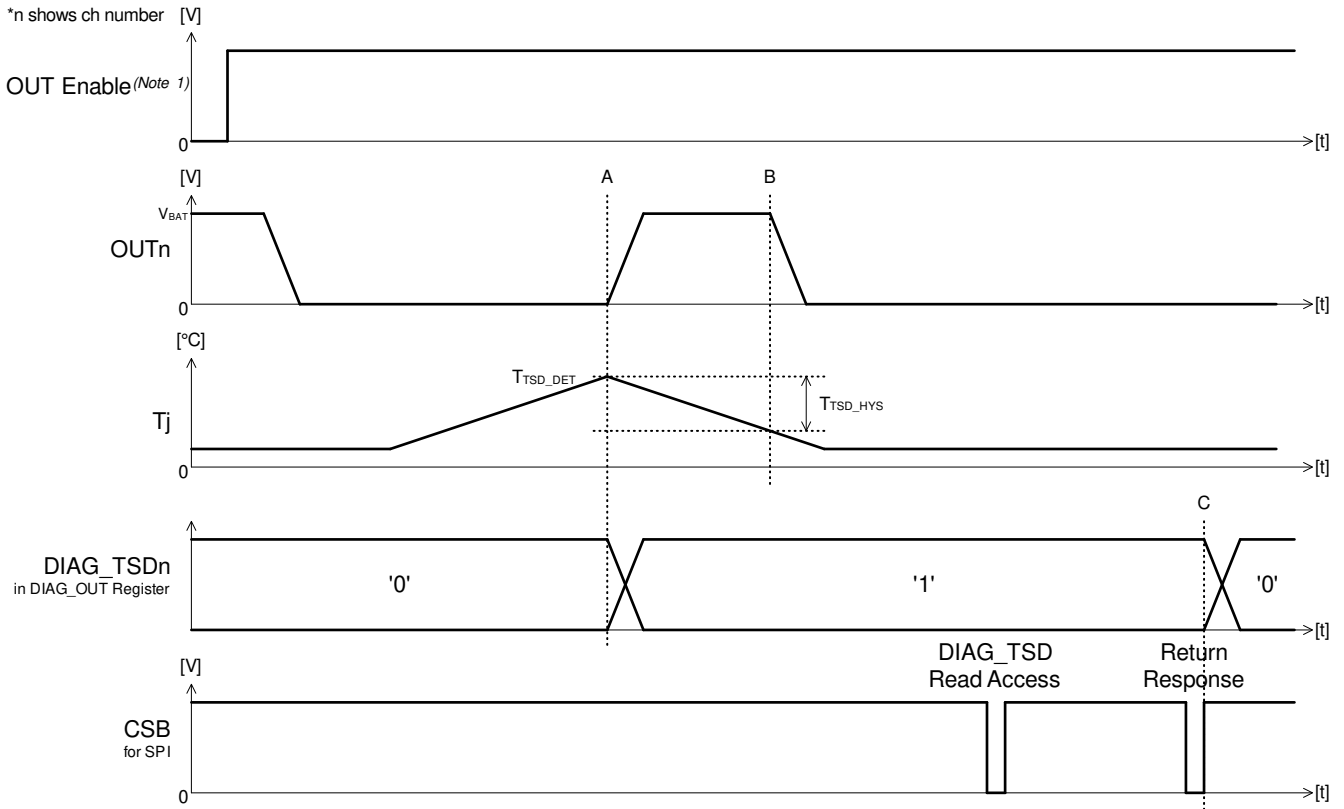

(Note 1) Output on/off control signal. This signal is controlled by IN87, IN65, IN43, IN21 or OUT_CTRL register.

Open Load Detection (OLD)

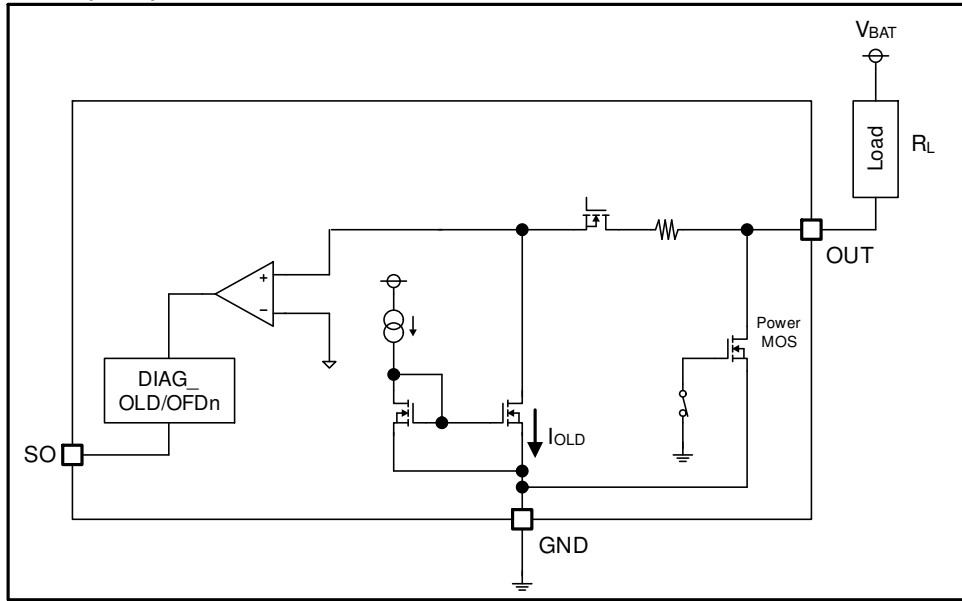

When OLD is enabled, output sink current I_{OLD} flows from OUT. The output voltage V_{OUT} drops when the load R_L increases, and it is detected as OLD when it becomes V_{OLD_DET} or less.

R_L for detecting OLDs is given by the following equation:

$$R_L \geq \frac{V_{BAT} - V_{OLD_DET}}{I_{OLD}}$$

- V_{BAT} : Battery voltage
- V_{OLD_DET} : Open load detection voltage 3.2 V (Max)
- I_{OLD} : Output sink current when OLD function is active 90 μ A (Max)

When the output is off, OLD can be enabled and diagnosed by one SPI access of write and read access (RE = 1, WE = 1) to DIAG_OLd/OFD register (B, F in the figure). Diagnostic is output to SO at the next SPI access (D, H in the figure). At this time, OLD returns to inactive (D, H in the figure). When OUTn voltage is V_{OLD_DET} or less, OLD is diagnosed as detected and the error flag inside the IC outputs "0" (C in the figure). If OUTn voltage is V_{OLD_REL} or more, OLD is diagnosed as undetected and the error flag output '1' (G in the figure).

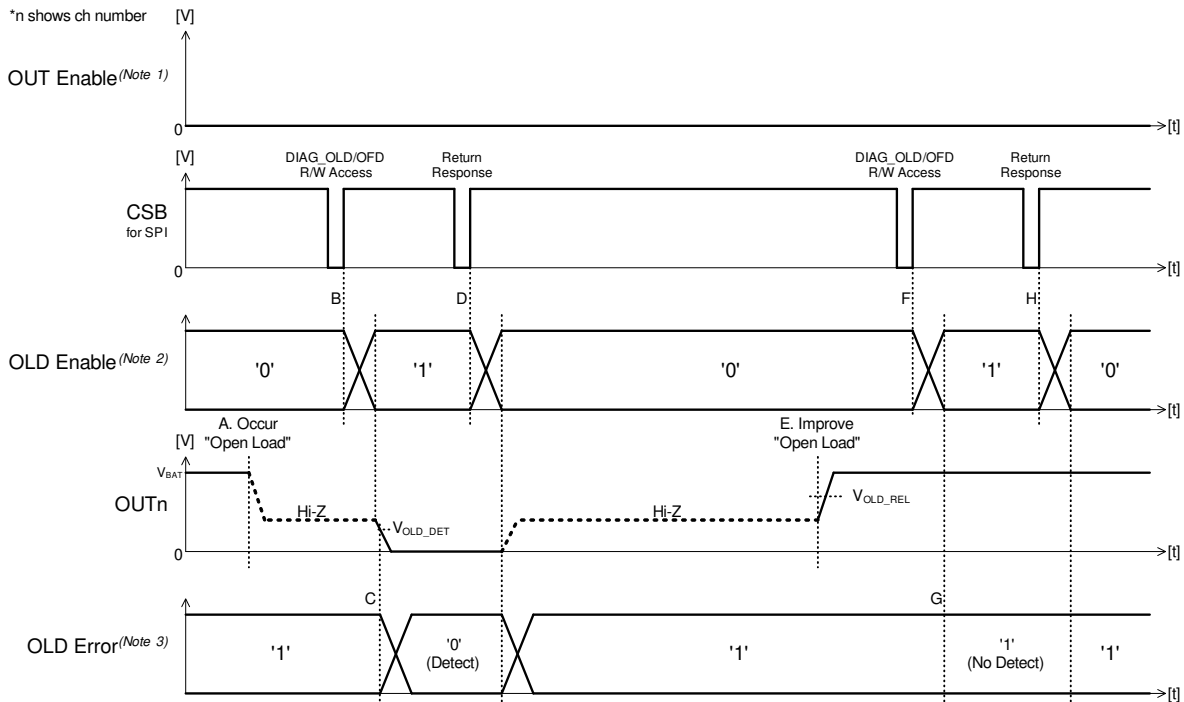

(Note 1) Output on/off control signal. This signal is controlled by IN87, IN65, IN43, IN21 or OUT_CTRL register.
 (Note 2) Internal enable signal. High and Low indicates enabled and disabled, respectively. This signal is controlled by write access to DIAG_OLd/OFD register.
 (Note 3) Internal error flag. High and Low indicates error undetected and detected, respectively. Also the flag outputs High during disable. This signal can be retrieved to SO by read access to DIAG_OLd/OFD register.

Output Overhead Fault Detection Function (OFD)

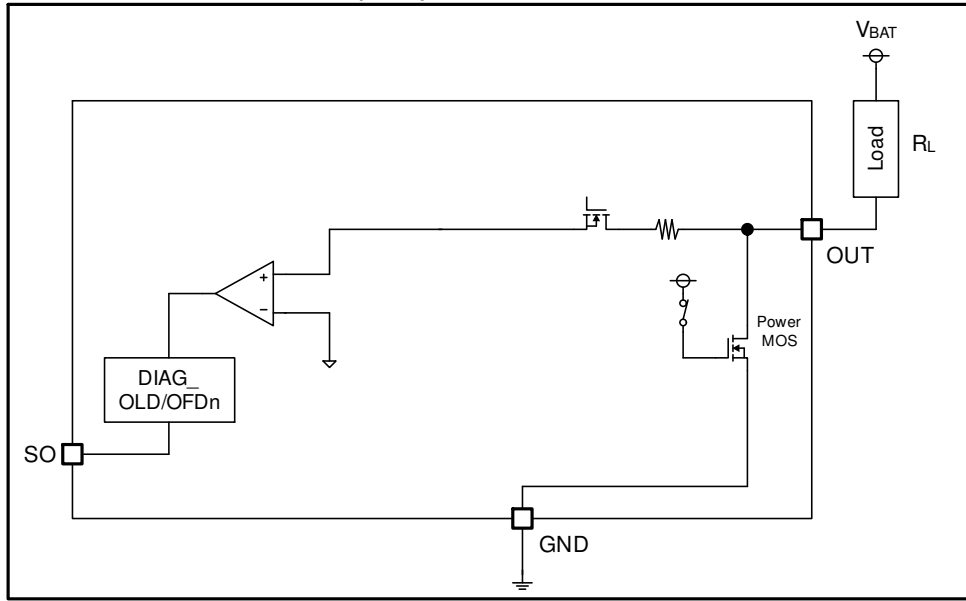

When the output is on, OFD can be enabled and diagnosed by one SPI access by write and read access (RE = 1, WE = 1) to DIAG_OLDFn register (B, F in the figure). Diagnostic is output to SO at the next SPI access (D, H in the figure). At this time, OFD returns to be inactive (D, H in the figure). When OUTn voltage is V_{OFD_DET} or more, OFD is diagnosed as detected and the error flag inside the IC outputs "1" (C in the figure). If OUTn voltage is V_{OFD_REL} or less, OFD is diagnosed as undetected and the error flag output '0' (G in the figure).

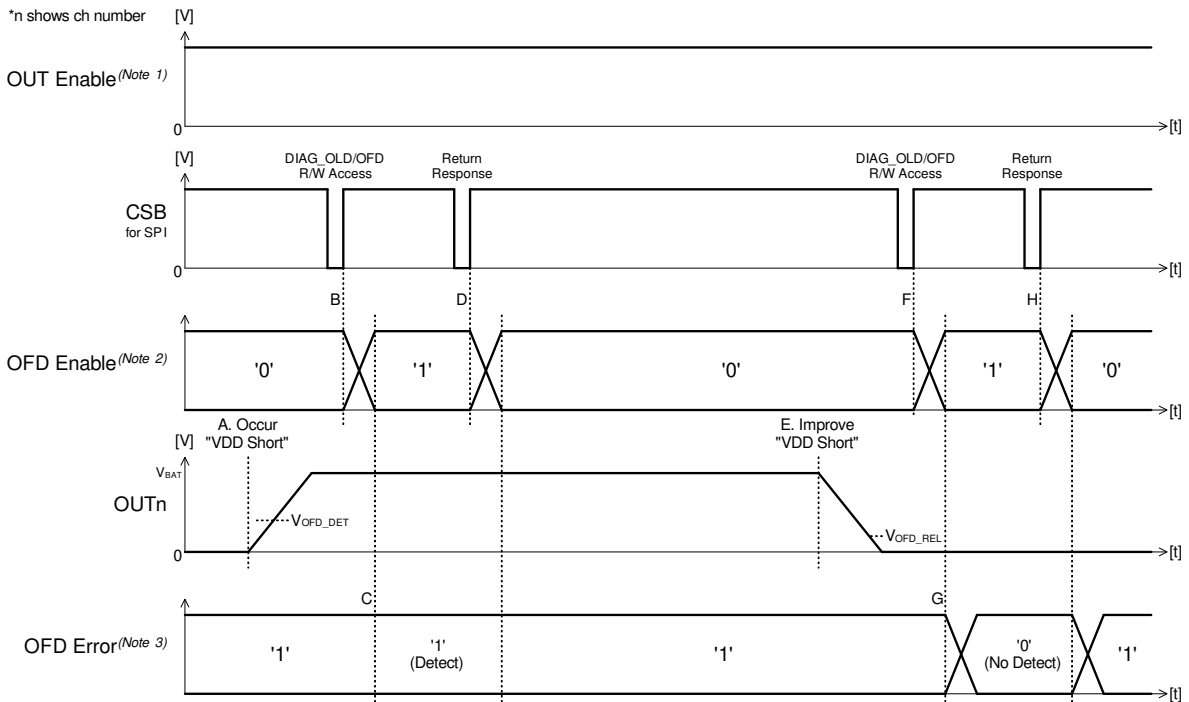

(Note 1) Output on/off control signal. High and Low indicates on and off, respectively. This signal is controlled by IN87, IN65, IN43, IN21 or OUT_CTRL register.
 (Note 2) Internal enable signal. High and Low indicates enabled and disabled, respectively. This signal is controlled by write access to DIAG_OLDFn register.
 (Note 3) Internal error flag. High and Low indicates error detected and undetected, respectively. Also the flag outputs High during disable. This signal can be retrieved to SO by read access to DIAG_OLDFn register.

Short Ground Detection (SGD)

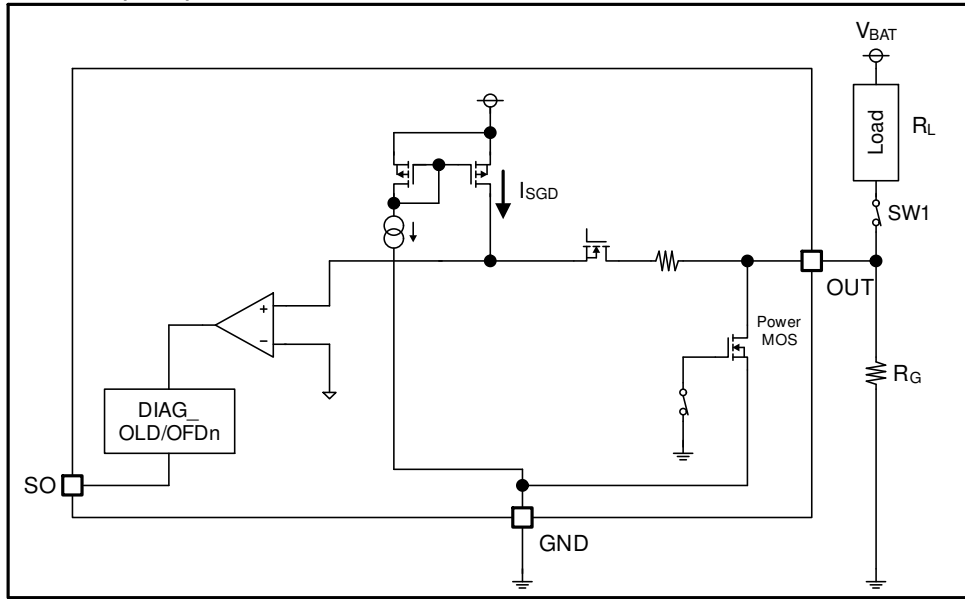

·When normal load is connected (SW1 is on)

The output voltage V_{OUT} is determined by the divided voltage between R_L (normal load) and R_G (OUT-GND impedance) and it is detected as SGD when V_{OUT} is V_{SGD_DET} or less. R_G for detecting SGD is given roughly by the following equation.

$$R_G \leq \frac{V_{SGD_DET}}{V_{BAT} - V_{SGD_DET}} * R_L$$

V_{BAT} : Battery voltage

V_{SGD_DET} : Short ground detection voltage 0.5 V (Min)

·When the load is open (SW1 is off)

The output voltage V_{OUT} is obtained from output source current I_{SGD} that flows into R_G and it is detected as SGD when V_{OUT} is V_{SGD_DET} or less.

R_G for detecting SGD is given by the following equation.

$$R_G \leq \frac{V_{SGD_DET}}{I_{SGD}}$$

V_{SGD_DET} : Short ground detection voltage 0.5 V (Min)

I_{SGD} : Output source current when SGD function is active 40 μ A (Max)

Short Ground Detection (SGD) – continued

When the output is off, SGD can be enabled and diagnosed by one SPI access of write and read access (RE = 1, WE = 1) to DIAG_SGD register (B, F in the figure). Diagnostic is output to SO at the next SPI access. At this time, SGD returns to be inactive (D, H in the figure). When OUTn voltage is V_{SGD_DET} or less, SGD is diagnosed as detected and the error flag inside the IC outputs "0" (C in the figure). If OUTn voltage is V_{SGD_REL} or more, SGD is diagnosed as undetected and the error flag output '1' (G in the figure).

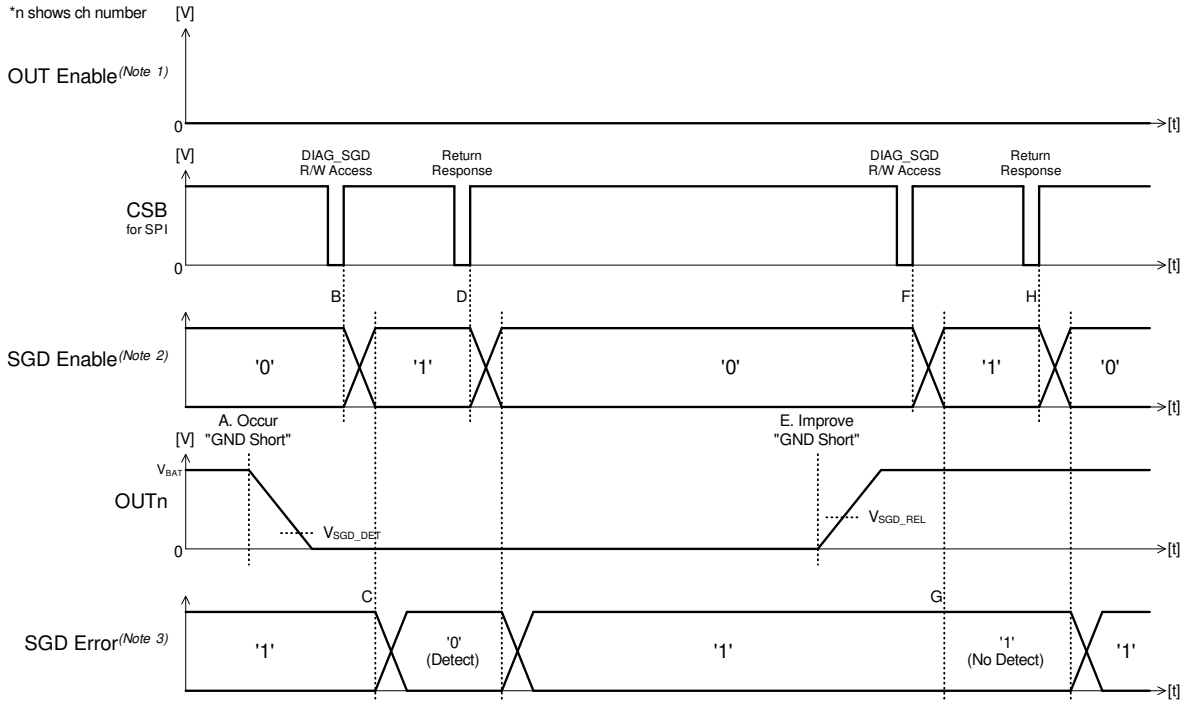

(Note 1) Output on/off control signal. This signal is controlled by IN87, IN65, IN43, IN21 or OUT_CTRL register.

(Note 2) Internal enable signal. High and Low indicates enabled and disabled, respectively. This signal is controlled by write access to DIAG_SGD register.

(Note 3) Internal error flag. High and Low indicates error undetected and detected, respectively. Also the flag outputs High during disable. This signal can be retrieved to SO by read access to DIAG_SGD register.

Application Example

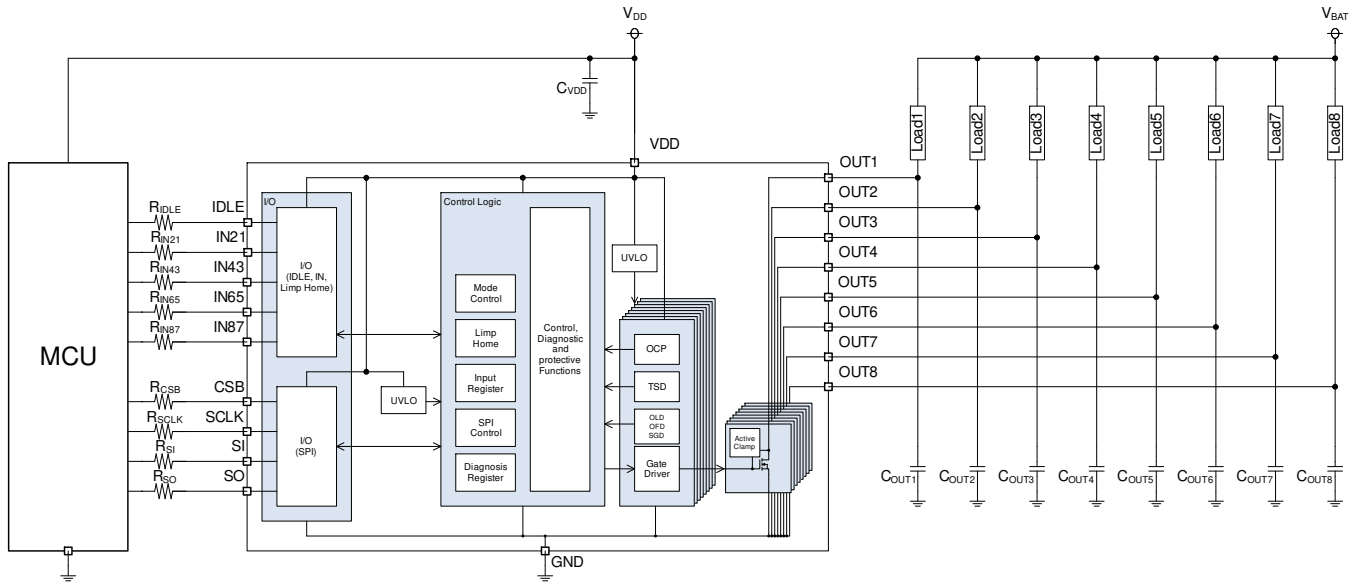

Selection of Components Externally Connected

Symbol	Value	Purpose
R _{IDLE}	1 kΩ	Register for microcontroller protection against negative voltage surge
R _{IN21} , R _{IN43} , R _{IN65} , R _{IN87}	1 kΩ	Register for microcontroller protection against negative voltage surge
R _{CSB} , R _{SCLK} , R _{SI} , R _{SO}	1 kΩ	Register for microcontroller protection against negative voltage surge
C _{VDD}	0.1 μF	Capacitor for noise removal on the power supply line
C _{OUT1} to C _{OUT8}	0.1 μF	Capacitor for ESD surge and BCI protection

As a precaution in selecting a C_{OUT}, current flows from the capacitor when the switch is turned on. Depending on the capacitance, over current protection may be detected. This current depends on the slew rate setting, over current protection setting, and V_{BAT} voltage. As a reference, capacitance that can be used with V_{BAT} = 18 V without over current protection when the switch is turned on is shown in the below table.

V _{BAT} = 18 V		
Slew Rate setting	Over Current Protection setting	Capacitance value that over current protection is not detected (Max)
SRCTRLn[1:0] = 00	OCPCTRLn = 0	0.22 μF
	OCPCTRLn = 1	0.22 μF
SRCTRLn[1:0] = 01	OCPCTRLn = 0	0.47 μF
	OCPCTRLn = 1	0.83 μF
SRCTRLn[1:0] = 10	OCPCTRLn = 0	0.68 μF
	OCPCTRLn = 1	1.5 μF

I/O Equivalence Circuits

Pin No.	Pin Name	I/O Equivalence Circuit
1	IDLE	
2	CSB	
3, 4 16 to 19	SCLK SI IN87 IN65 IN43 IN21	
5	SO	
6, 15	GND	-
7 to 14	OUT1 to OUT8	
20	VDD	-

Operational Notes

1. Reverse Connection of Power Supply

Connecting the power supply in reverse polarity can damage the IC. Take precautions against reverse polarity when connecting the power supply, such as mounting an external diode between the power supply and the IC's power supply pins.

2. Power Supply Lines

Design the PCB layout pattern to provide low impedance supply lines. Separate the ground and supply lines of the digital and analog blocks to prevent noise in the ground and supply lines of the digital block from affecting the analog block. Furthermore, connect a capacitor to ground at all power supply pins. Consider the effect of temperature and aging on the capacitance value when using electrolytic capacitors.

3. Ground Voltage

Ensure that no pins are at a voltage below that of the ground pin at any time, even during transient condition.

4. Ground Wiring Pattern

When using both small-signal and large-current ground traces, the two ground traces should be routed separately but connected to a single ground at the reference point of the application board to avoid fluctuations in the small-signal ground caused by large currents. Also ensure that the ground traces of external components do not cause variations on the ground voltage. The ground lines must be as short and thick as possible to reduce line impedance.

5. Recommended Operating Conditions

The function and operation of the IC are guaranteed within the range specified by the recommended operating conditions. The characteristic values are guaranteed only under the conditions of each item specified by the electrical characteristics.

6. Inrush Current

When power is first supplied to the IC, it is possible that the internal logic may be unstable and inrush current may flow instantaneously due to the internal powering sequence and delays, especially if the IC has more than one power supply. Therefore, give special consideration to power coupling capacitance, power wiring, width of ground wiring, and routing of connections.

7. Testing on Application Boards

When testing the IC on an application board, connecting a capacitor directly to a low-impedance output pin may subject the IC to stress. Always discharge capacitors completely after each process or step. The IC's power supply should always be turned off completely before connecting or removing it from the test setup during the inspection process. To prevent damage from static discharge, ground the IC during assembly and use similar precautions during transport and storage.

8. Inter-pin Short and Mounting Errors

Ensure that the direction and position are correct when mounting the IC on the PCB. Incorrect mounting may result in damaging the IC. Avoid nearby pins being shorted to each other especially to ground, power supply and output pin. Inter-pin shorts could be due to many reasons such as metal particles, water droplets (in very humid environment) and unintentional solder bridge deposited in between pins during assembly to name a few.

9. Unused Input Pins

Input pins of an IC are often connected to the gate of a MOS transistor. The gate has extremely high impedance and extremely low capacitance. If left unconnected, the electric field from the outside can easily charge it. The small charge acquired in this way is enough to produce a significant effect on the conduction through the transistor and cause unexpected operation of the IC. So unless otherwise specified, unused input pins should be connected to the power supply or ground line.

Operational Notes – continued

10. Regarding the Input and Output Pins of the IC

This monolithic IC contains P+ isolation and P substrate layers between adjacent elements in order to keep them isolated. P-N junctions are formed at the intersection of the P layers with the N layers of other elements, creating a parasitic diode or transistor. For example (refer to figure below):

When $GND > Pin A$ and $GND > Pin B$, the P-N junction operates as a parasitic diode.

When $GND > Pin B$, the P-N junction operates as a parasitic transistor.

Parasitic diodes inevitably occur in the structure of the IC. The operation of parasitic diodes can result in mutual interference among circuits, operational faults, or physical damage. Therefore, conditions that cause these diodes to operate, such as applying a voltage lower than the GND voltage to an input pin (and thus to the P substrate) should be avoided.

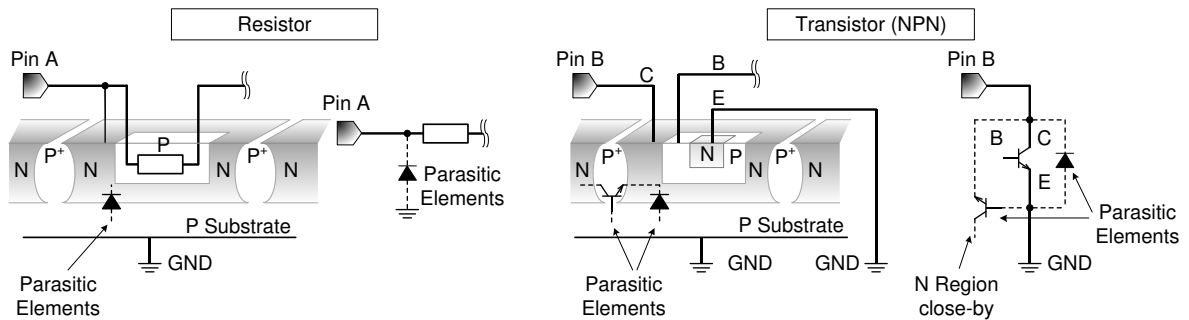

Figure 54. Example of Monolithic IC Structure

11. Ceramic Capacitor

When using a ceramic capacitor, determine a capacitance value considering the change of capacitance with temperature and the decrease in nominal capacitance due to DC bias and others.

12. Thermal Shutdown Function (TSD)

This IC has a built-in thermal shutdown function that prevents heat damage to the IC. Normal operation should always be within the IC's maximum junction temperature rating. If however the rating is exceeded for a continued period, the junction temperature (T_j) will rise which will activate the TSD function that will turn OFF power output pins. When the T_j falls below the TSD threshold, the circuits are automatically restored to normal operation.

Note that the TSD function operates in a situation that exceeds the absolute maximum ratings and therefore, under no circumstances, should the TSD function be used in a set design or for any purpose other than protecting the IC from heat damage.

13. Over Current Protection Function (OCP)

This IC incorporates an integrated overcurrent protection function that is activated when the load is shorted. This protection function is effective in preventing damage due to sudden and unexpected incidents. However, the IC should not be used in applications characterized by continuous operation or transitioning of the protection function.

14. Active Clamp Operation

The IC integrates the active clamp function to internally absorb the reverse energy E_L which is generated when the inductive load is turned off. When the active clamp operates, the thermal shutdown function does not work. Decide a load so that the reverse energy E_L is active clamp tolerance E_{AS} (refer to Figure 1.), $E_{S,AS}$ (refer to Figure 2.) or under when inductive load is used.

Operational Notes – continued

15. Power Supply Step Fluctuation

If the voltage of the power supply pin (VDD) falls sharply, the output pin (OUT) may temporarily turn off as shown in Figure 55. If the power supply pin is expected to fall sharply, take measures such as inserting a capacitor between the power supply pin and the ground pin so that it falls within the recommended usage range shown in Figure 56.

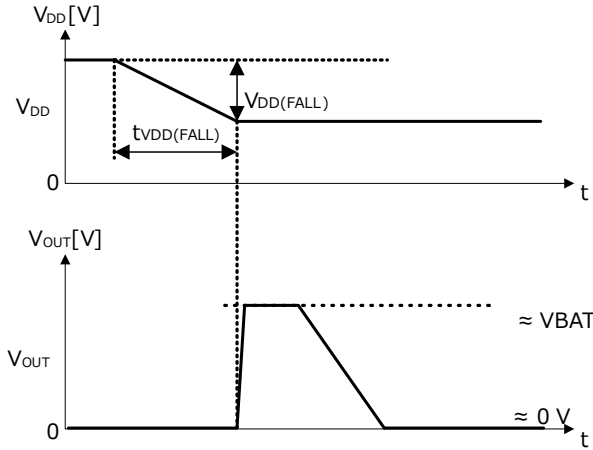

Figure 55. Output OFF operation when power supply fluctuates sharply

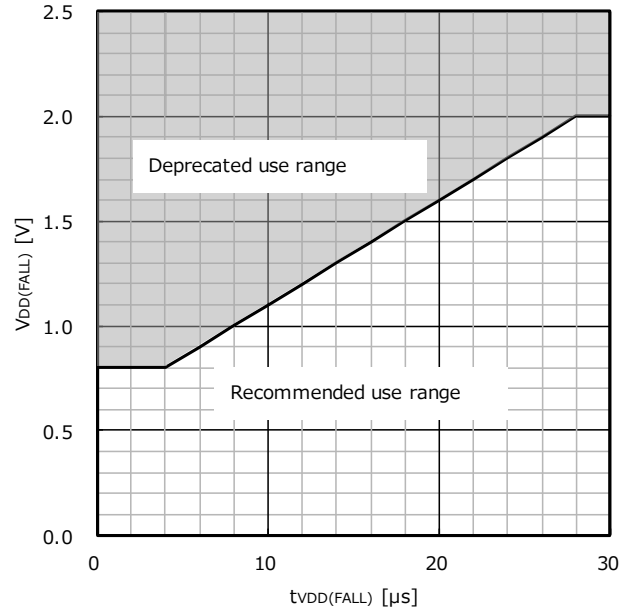
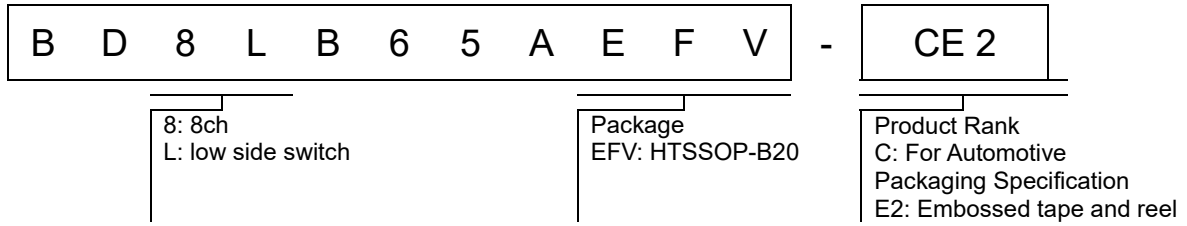

Figure 56. Recommended use range

16. GND Pin Connection

Connect all ground pins to ground.

Ordering Information



Marking Diagram

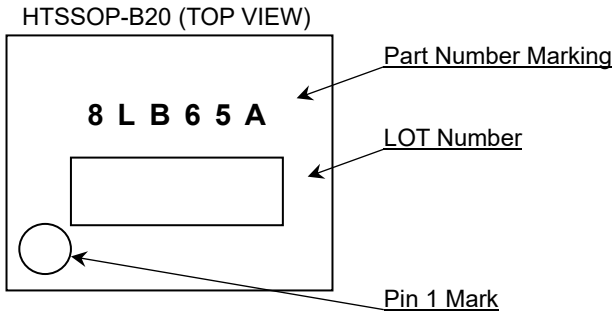

Physical Dimension and Packing Information

Package Name	HTSSOP-B20
--------------	------------

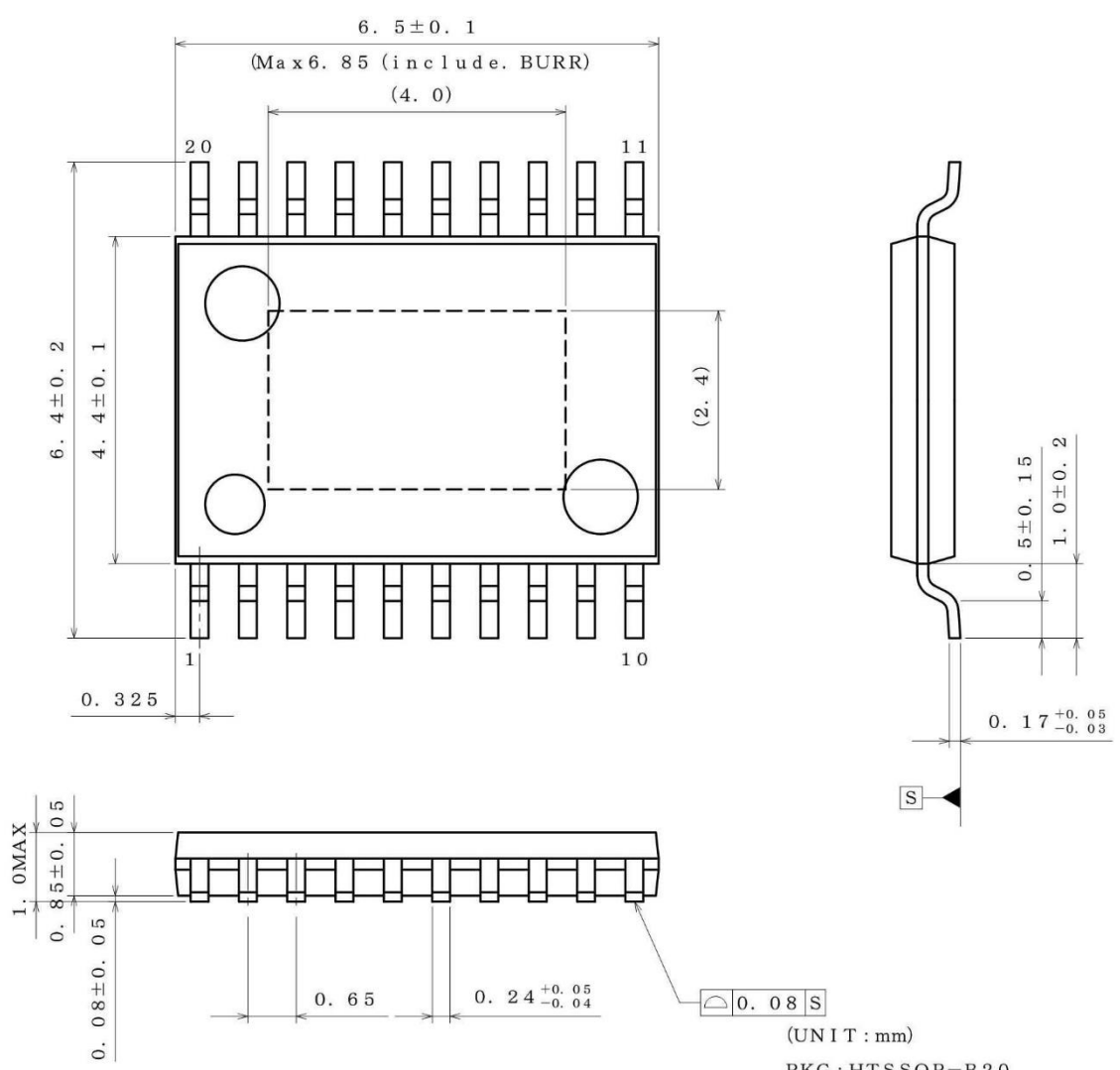

< Tape and Reel Information >

Tape	Embossed carrier tape
Quantity	2500pcs
Direction of feed	E2 The direction is the pin 1 of product is at the upper left when you hold reel on the left hand and you pull out the tape on the right hand

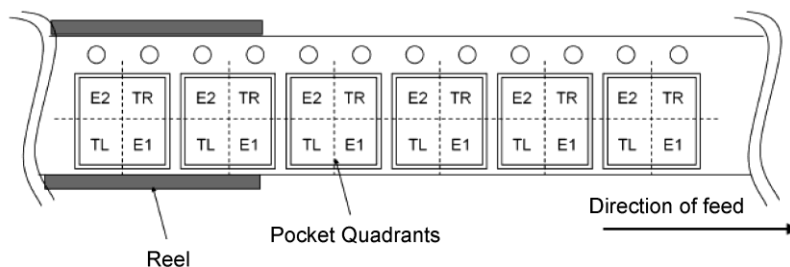

Revision History

Date	Revision	Changes
26.Aug.2022	001	New Release

Notice

Precaution on using ROHM Products

1. If you intend to use our Products in devices requiring extremely high reliability (such as medical equipment ^(Note 1), aircraft/spacecraft, nuclear power controllers, etc.) and whose malfunction or failure may cause loss of human life, bodily injury or serious damage to property ("Specific Applications"), please consult with the ROHM sales representative in advance. Unless otherwise agreed in writing by ROHM in advance, ROHM shall not be in any way responsible or liable for any damages, expenses or losses incurred by you or third parties arising from the use of any ROHM's Products for Specific Applications.

(Note1) Medical Equipment Classification of the Specific Applications

JAPAN	USA	EU	CHINA
CLASS III	CLASS III	CLASS II b	CLASS III
CLASS IV		CLASS III	

2. ROHM designs and manufactures its Products subject to strict quality control system. However, semiconductor products can fail or malfunction at a certain rate. Please be sure to implement, at your own responsibilities, adequate safety measures including but not limited to fail-safe design against the physical injury, damage to any property, which a failure or malfunction of our Products may cause. The following are examples of safety measures:
 - [a] Installation of protection circuits or other protective devices to improve system safety
 - [b] Installation of redundant circuits to reduce the impact of single or multiple circuit failure
3. Our Products are not designed under any special or extraordinary environments or conditions, as exemplified below. Accordingly, ROHM shall not be in any way responsible or liable for any damages, expenses or losses arising from the use of any ROHM's Products under any special or extraordinary environments or conditions. If you intend to use our Products under any special or extraordinary environments or conditions (as exemplified below), your independent verification and confirmation of product performance, reliability, etc. prior to use, must be necessary:
 - [a] Use of our Products in any types of liquid, including water, oils, chemicals, and organic solvents
 - [b] Use of our Products outdoors or in places where the Products are exposed to direct sunlight or dust
 - [c] Use of our Products in places where the Products are exposed to sea wind or corrosive gases, including Cl₂, H₂S, NH₃, SO₂, and NO₂
 - [d] Use of our Products in places where the Products are exposed to static electricity or electromagnetic waves
 - [e] Use of our Products in proximity to heat-producing components, plastic cords, or other flammable items
 - [f] Sealing or coating our Products with resin or other coating materials
 - [g] Use of our Products without cleaning residue of flux (Exclude cases where no-clean type fluxes is used. However, recommend sufficiently about the residue.); or Washing our Products by using water or water-soluble cleaning agents for cleaning residue after soldering
 - [h] Use of the Products in places subject to dew condensation
4. The Products are not subject to radiation-proof design.
5. Please verify and confirm characteristics of the final or mounted products in using the Products.
6. In particular, if a transient load (a large amount of load applied in a short period of time, such as pulse, is applied, confirmation of performance characteristics after on-board mounting is strongly recommended. Avoid applying power exceeding normal rated power; exceeding the power rating under steady-state loading condition may negatively affect product performance and reliability.
7. De-rate Power Dissipation depending on ambient temperature. When used in sealed area, confirm that it is the use in the range that does not exceed the maximum junction temperature.
8. Confirm that operation temperature is within the specified range described in the product specification.
9. ROHM shall not be in any way responsible or liable for failure induced under deviant condition from what is defined in this document.

Precaution for Mounting / Circuit board design

1. When a highly active halogenous (chlorine, bromine, etc.) flux is used, the residue of flux may negatively affect product performance and reliability.
2. In principle, the reflow soldering method must be used on a surface-mount products, the flow soldering method must be used on a through hole mount products. If the flow soldering method is preferred on a surface-mount products, please consult with the ROHM representative in advance.

For details, please refer to ROHM Mounting specification

Precautions Regarding Application Examples and External Circuits

1. If change is made to the constant of an external circuit, please allow a sufficient margin considering variations of the characteristics of the Products and external components, including transient characteristics, as well as static characteristics.
2. You agree that application notes, reference designs, and associated data and information contained in this document are presented only as guidance for Products use. Therefore, in case you use such information, you are solely responsible for it and you must exercise your own independent verification and judgment in the use of such information contained in this document. ROHM shall not be in any way responsible or liable for any damages, expenses or losses incurred by you or third parties arising from the use of such information.

Precaution for Electrostatic

This Product is electrostatic sensitive product, which may be damaged due to electrostatic discharge. Please take proper caution in your manufacturing process and storage so that voltage exceeding the Products maximum rating will not be applied to Products. Please take special care under dry condition (e.g. Grounding of human body / equipment / solder iron, isolation from charged objects, setting of Ionizer, friction prevention and temperature / humidity control).

Precaution for Storage / Transportation

1. Product performance and soldered connections may deteriorate if the Products are stored in the places where:
 - [a] the Products are exposed to sea winds or corrosive gases, including Cl₂, H₂S, NH₃, SO₂, and NO₂
 - [b] the temperature or humidity exceeds those recommended by ROHM
 - [c] the Products are exposed to direct sunshine or condensation
 - [d] the Products are exposed to high Electrostatic
2. Even under ROHM recommended storage condition, solderability of products out of recommended storage time period may be degraded. It is strongly recommended to confirm solderability before using Products of which storage time is exceeding the recommended storage time period.
3. Store / transport cartons in the correct direction, which is indicated on a carton with a symbol. Otherwise bent leads may occur due to excessive stress applied when dropping of a carton.
4. Use Products within the specified time after opening a humidity barrier bag. Baking is required before using Products of which storage time is exceeding the recommended storage time period.

Precaution for Product Label

A two-dimensional barcode printed on ROHM Products label is for ROHM's internal use only.

Precaution for Disposition

When disposing Products please dispose them properly using an authorized industry waste company.

Precaution for Foreign Exchange and Foreign Trade act

Since concerned goods might be fallen under listed items of export control prescribed by Foreign exchange and Foreign trade act, please consult with ROHM in case of export.

Precaution Regarding Intellectual Property Rights

1. All information and data including but not limited to application example contained in this document is for reference only. ROHM does not warrant that foregoing information or data will not infringe any intellectual property rights or any other rights of any third party regarding such information or data.
2. ROHM shall not have any obligations where the claims, actions or demands arising from the combination of the Products with other articles such as components, circuits, systems or external equipment (including software).
3. No license, expressly or implied, is granted hereby under any intellectual property rights or other rights of ROHM or any third parties with respect to the Products or the information contained in this document. Provided, however, that ROHM will not assert its intellectual property rights or other rights against you or your customers to the extent necessary to manufacture or sell products containing the Products, subject to the terms and conditions herein.

Other Precaution

1. This document may not be reprinted or reproduced, in whole or in part, without prior written consent of ROHM.
2. The Products may not be disassembled, converted, modified, reproduced or otherwise changed without prior written consent of ROHM.
3. In no event shall you use in any way whatsoever the Products and the related technical information contained in the Products or this document for any military purposes, including but not limited to, the development of mass-destruction weapons.
4. The proper names of companies or products described in this document are trademarks or registered trademarks of ROHM, its affiliated companies or third parties.

General Precaution

1. Before you use our Products, you are requested to carefully read this document and fully understand its contents. ROHM shall not be in any way responsible or liable for failure, malfunction or accident arising from the use of any ROHM's Products against warning, caution or note contained in this document.
2. All information contained in this document is current as of the issuing date and subject to change without any prior notice. Before purchasing or using ROHM's Products, please confirm the latest information with a ROHM sales representative.
3. The information contained in this document is provided on an "as is" basis and ROHM does not warrant that all information contained in this document is accurate and/or error-free. ROHM shall not be in any way responsible or liable for any damages, expenses or losses incurred by you or third parties resulting from inaccuracy or errors of or concerning such information.