

THIS DRAWING IS UNPUBLISHED.
 VERTRAULICHE UNVERÖFFENTLICHTE ZEICHNUNG
 © COPYRIGHT - By -
 RELEASED FOR PUBLICATION
 FREI FUER VERÖFFENTLICHUNG
 ALL RIGHTS RESERVED.
 ALLE RECHTE VORBEHALTEN

REVISIONS ÄNDERUNGEN					
P	LTR	DESCRIPTION BESCHREIBUNG	DATE	DWN	APVD
	C7	REVISED PER ECR-17-014951	16OCT2017	BDA	KR

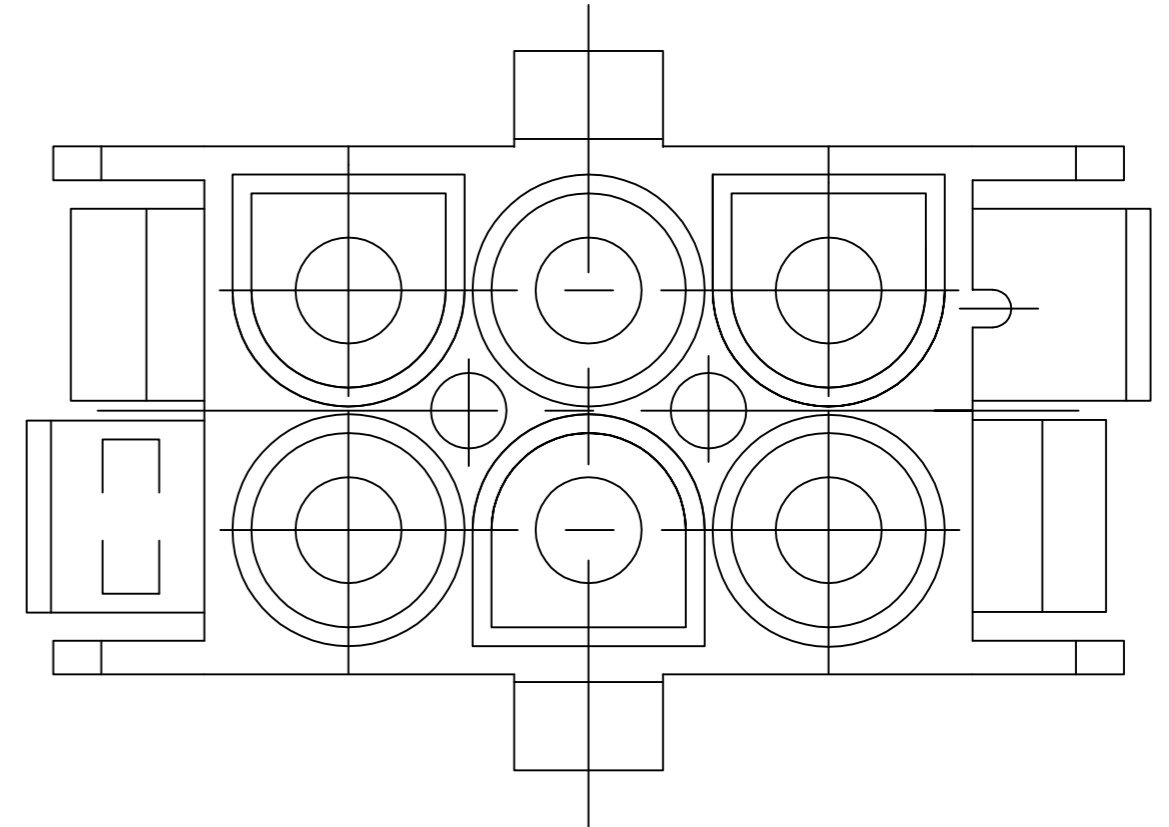
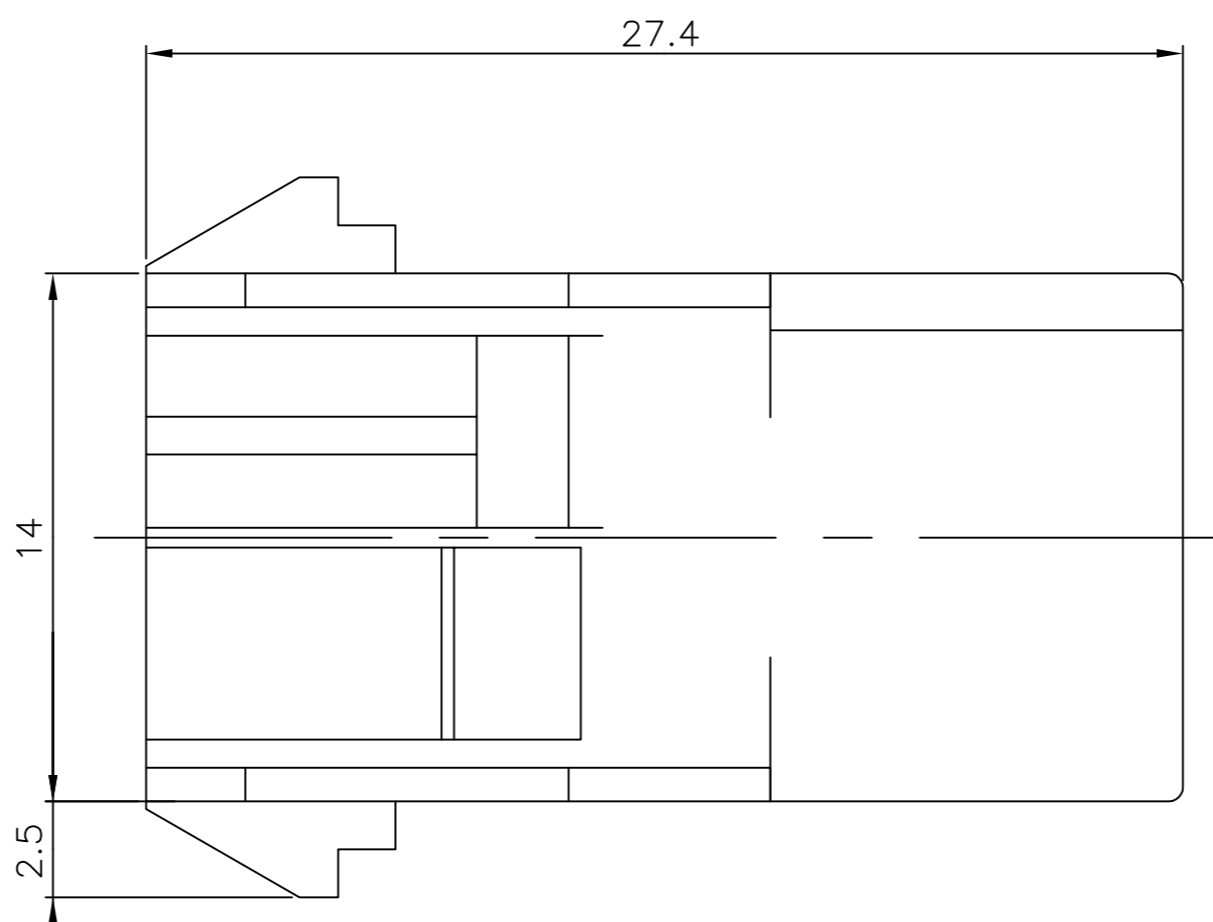
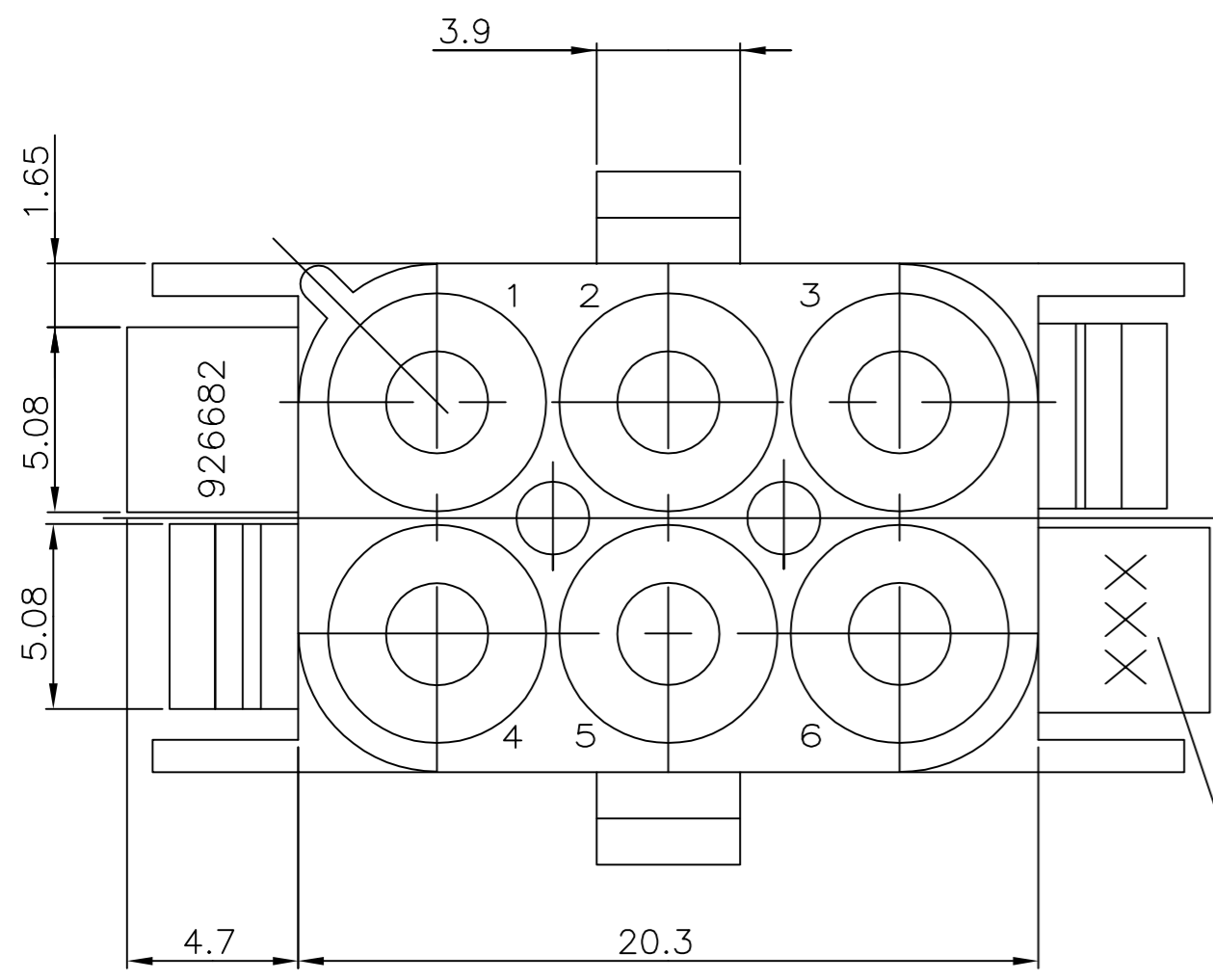

Bemerkungen:
NOTES

- 1 Geeignet für UMNL Stift- und Buchsenkontakte
BEEN SUITABLE FOR UMNL PIN- AND SOCKET CONTACTS
- 2 Empfohlene Blechstärke 0.75 - 2.3 mm
RECOMMEND SHEET METAL THICKNESS 0.75 - 2.3 mm
- 3 Gehäuse muß in Stanzrichtung eingeführt werden
HOUSING MUST BE INTRODUCED TO PUNCHING DIRECTION
- 4 Für verschlüsseltes Einsetzen der Gehäuse
FOR CODED USING OF THE HOUSING
- 5 Position von Kammer 1 bei Verschlüsseltem Einsetzen
POSITION OF CAVITY 1 FOR CODED USING
- 6 Neues Material (Phosphor und Halogen frei)
NEW MATERIAL (PHOSPHORUS AND HALOGENEOUS FREE)
- 7 Hersteller-Logo und Ländercode nach TE-SPEZ. 115-18016
BRANDNAME AND MANUFACTURING LOCATION CODE ACCORDING TE-SPEC. 115-18016
- 8 MATERIAL CORRESPONDING TO THE REQUIRMENT OF IEC 60335-1
(INCL. GLOW WIRE TEST 750°C WITH OUT FLAME)
- 9 PRELIMINARY PART NOT RELEASED FOR PRODUCTION
- 10 MATERIAL P/N: 702641-1.
- 11 CSA LOGO LOCATED AT LEAST ONE SIDE OF THE HOUSING, LOCATED AS SHOWN
- 12 DIMENSIONS SHOWN REPRESENT PRODUCT IN DRY, AS MOLDED, CONDITION. ADDITIONAL 2% GROWTH DUE TO SUBSEQUENT MOISTURE ABSORPTION MAY OCCUR AND SHOULD BE ACCOUNTED FOR.

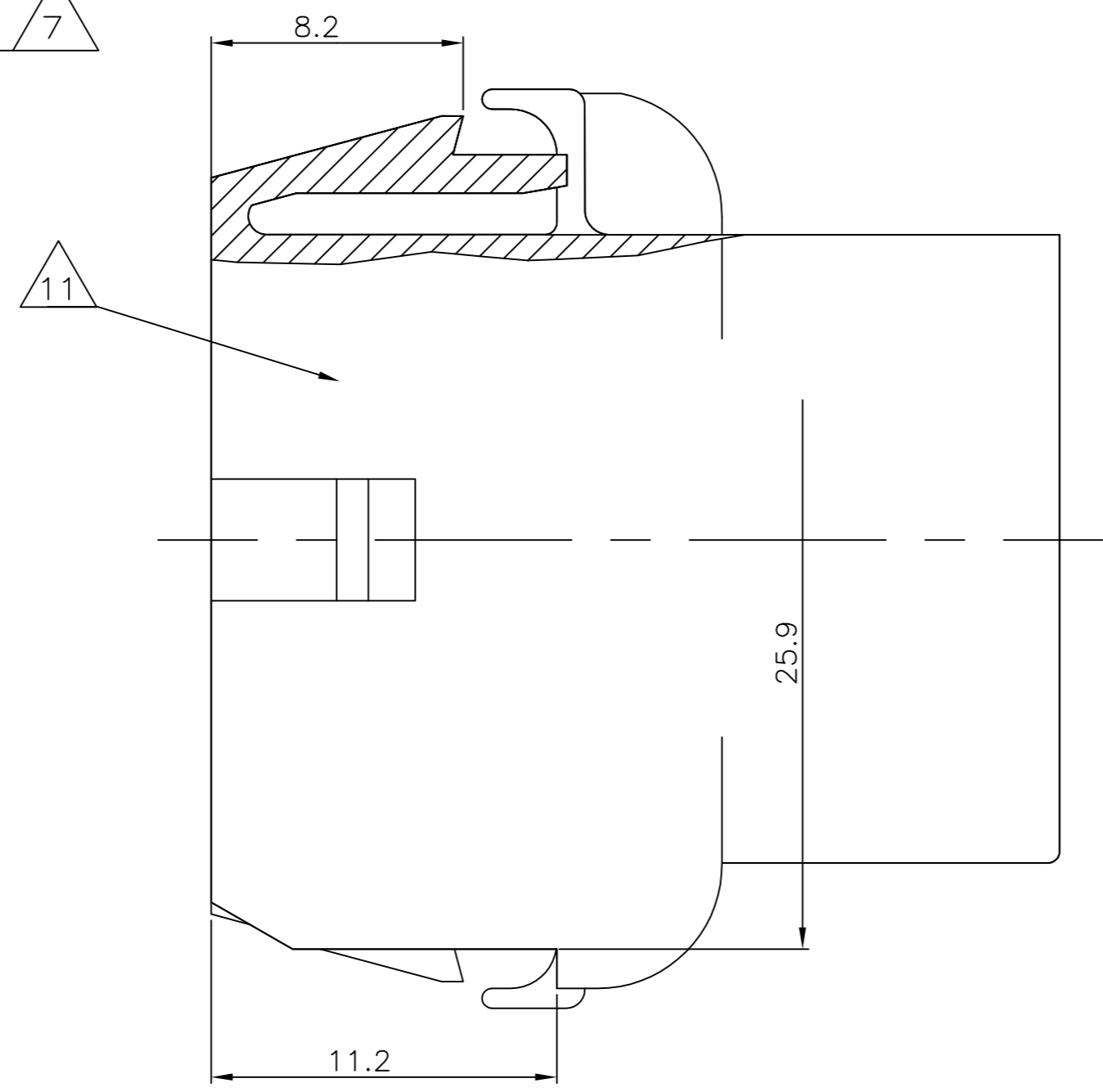

Montageausschnitt / PANEL CUT OUT
 Bestückungsseite / LOADING SIDE
 M 2:1 / SCALE 2:1

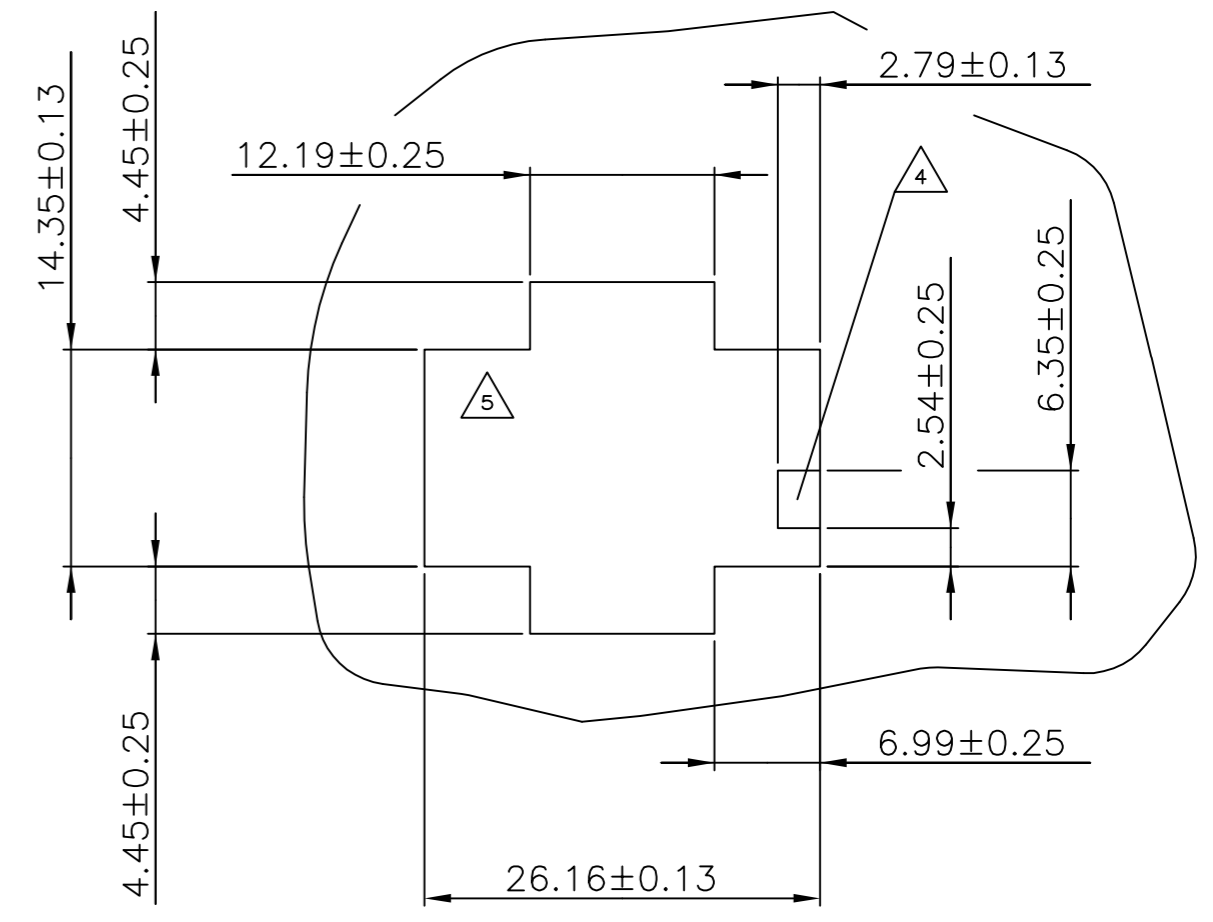

PART NO	REV.	MATERIAL	COLOR
926682-7	1	PA6.UL94 V 0 ⁸ / ₉	natur/NATURAL
OBSOLETE -926682-6	C	PA6.6 UL94 V 2 (ZYTEL E 103 HSL)	natur/NATURAL
OBSOLETE -926682-5	C	PA6.6 UL94 V 2 (ZYTEL ...135F)	natur/NATURAL
926682-4	C	PA6.6 UL94 V 2 (ZYTEL ...135F) ¹⁰	weiß/WHITE
926682-3	C	PA6.6 UL94 V 0 (ULTRAMID C3U)	⁶ natur/NATURAL
OBSOLETE -926682-2	C	PA6.6 UL94 V 2 (ZYTEL ...135F)	schwarz/BLACK
926682-1	C	PA6.6 UL94 V 2 (ZYTEL E 101)	natur/NATURAL

THIS DRAWING IS A CONTROLLED DOCUMENT.
 DIESE ZEICHNUNG IST EIN KONTROLLIERTES DOKUMENT.
 DIMENSIONS: MASSENHEITEN mm
 TOLERANCES UNLESS OTHERWISE SPECIFIED:
 ANGLES / WINKEL ± -
 FINISH / OBERFLÄCHE / FARBE

DWN Abraham.G. 11-MAR-03	 TE Connectivity 6-pol. UMNL Aufnahmegehäuse UMNL 6-WAY CAP HOUSING	SIZE A2	CAGE CODE 00779	DRAWING NO. ZEICHNUNGS-NR. C=926682	RESTRICTED TO NUR FUER -
CHK Kammann.H. 12-MAR-03		PRODUCT SPEC 108-1031	APPLICATION SPEC 114-18011	WEIGHT 0,000000	SCALE MASSTAB 5:1
APVD -		APPLICATION SPEC 114-18011	WEIGHT 0,000000	SHEET 1 von 1	REV C7
CUSTOMER DRAWING / KUNDENZEICHNUNG		SCALE MASSTAB 5:1	SHEET 1 von 1	REV C7	