

PART NUMBER	REVISION	DESCRIPTION	FEED TYPE
2150625-1	B	FINE CRIMP HEIGHT ADJUST	MECHANICAL
2150625-2	B	FINE CRIMP HEIGHT ADJUST	PNEUMATIC
7-2150625-1	B	MECHANICAL AND CRIMP TOOLING KIT	MECHANICAL
7-2150625-2	B	PNEUMATIC AND CRIMP TOOLING KIT	PNEUMATIC
7-2150625-7	A	CRIMP TOOLING KIT	-

ATLANTIC VERSION TERMINATOR INTERFACE ADAPTER

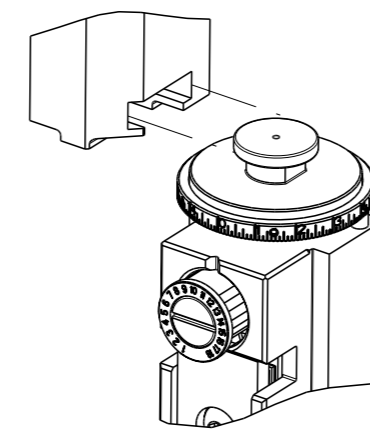

APPLICATOR DATA		
CRIMP	SIZE	TYPE
WIRE	1.27 mm [.050]	F
INSUL	1.40 mm [.055]	O
APPL INSTRUCTIONS 408-35043		

TERMINAL DATA: FCI TERMINAL		TE CRIMP SPECIFICATION	
TERMINAL NAME: TERMINAL, CTW MINI PV SMALL INSULATION			
WIRE STRIP LENGTH 3.74-4.50 mm [1.47-.177 IN]		INSULATION DIAMETER RANGE Ø 0.51-1.14 mm [0.020-.045 IN]	
TERMINAL APPLICATION SPECIFICATION	NONE	-	-
TERMINALS APPLIED			
TE TERMINAL	FCI TERMINAL	TE TERMINAL	FCI TERMINAL
2113909-1	75231-013	2113909-6	75231-027
2113909-2	75231-014	2113909-7	75231-030
2113909-3	75231-015	2113909-8	75231-031
2113909-4	75231-025	2113909-9	75231-032
2113909-5	75231-026		

WIRE SIZE	CRIMP HEIGHT mm [INCH]	CRIMP HEIGHT REFERENCE SETTING
22 AWG	0.95 +/- 0.05 [0.037 +/- .002]	7.7
24 AWG	0.86 +/- 0.05 [0.034 +/- .002]	8.8
26 AWG	0.81 +/- 0.05 [0.032 +/- .002]	9.3

- △ RECOMMENDED SPARE PARTS
 - △ REFER TO SUPPLIED INSTRUCTION SHEET FOR CLEANING, LUBRICATION AND STORAGE OF APPLICATOR.
 - △ APPLY PART NUMBER 1-23419-5 LOCTITE TO THREADS OF ITEM 180. APPLY PART NUMBER 2-23419-6 LOCTITE TO THREADS OF ITEM 242.
 - △ CRIMP HEIGHT REFERENCE SETTING WAS THE SETTING USED WHEN THE APPLICATOR WAS QUALIFIED AT THE FACTORY. ADJUSTMENT MAY BE NECESSARY WHEN RUNNING APPLICATOR IN THE FIELD.
 - △ TERMINAL LUBRICANT IS RECOMMENDED.
6. UNLESS SPECIFIED OTHERWISE TORQUE VALUES SHALL BE USED PER DOCUMENT, 101-35000.

***WARNING**
ON INSTALLATION, SET WIRE DISC TO CRIMP HEIGHT REFERENCE SETTING FOR LARGEST WIRE SIZE. CRIMP HEIGHT REFERENCE SETTINGS GREATER THAN THE VALUE SHOWN MAY CAUSE DAMAGE TO THE CRIMP TOOLING, REFER TO THE INSTRUCTION SHEET FOR PROPER SETUP AND ADJUSTMENTS.

ATLANTIC VERSION
Shown on sheets 1 of 4 & 2 of 4
(Pacific version shown on sheets 3 of 4 & 4 of 4)

LOC	DIST	REVISIONS					
A	66	#	LY#	DESCRIPTION	DATE	OWN	APVD
		A		RELEASED	04DEC2015	BW	TE
		B		ECR-20-006750	12MAY2020	LG	RR

-	1	-	1	-	2119641-1	FEED CAM, AIR FEED	248
-	1	1	1	1	2119082-5	CAM, SNAIL, INSULATION ADJUSTMENT	244
-	1	1	1	1	2079764-1	WASHER, WAVE SPRING, CREST-TO-CREST	243
-	1	1	1	1	2119083-1	RETAINER, INSULATION DIAL	242
-	-	1	-	1	2119580-1	MECHANICAL FEED ASSEMBLY	239
-	1	-	1	-	2844940-3	AIR FEED MODULE	238
-	1	1	1	1	1-18028-0	WASHER, FLAT, REG M8	192
-	1	1	1	1	1752354-5	STANDOFF, HOLD-DOWN	180
-	1	1	1	1	6-993111-6	PIN, SLOTTED SPRING 3.0 X 14.0	177
-	1	1	1	1	8-22280-7	SPRING, COMPRESSION	176
-	1	1	1	1	1752353-2	GUIDE PIN, HOLDDOWN	175
-	1	1	1	1	1901680-2	GUIDE PIN, HOLDDOWN	174
-	REF	REF	REF	REF	994970-2	COUNTER, MAGNETIC	164
-	1	1	1	1	2119955-2	ASSY, LUBRICATOR, END FEED	84
-	1	1	1	1	455888-5	SPACER, CRIMPER	82
-	1	1	1	1	1803607-4	DOCUMENTATION PACKAGE	71
-	2	2	2	2	2-18032-2	SCR, SET, FLT PNT, M3 X 10.0	70
-	1	1	1	1	2119740-1	TAG, IDENTIFICATION	67
-	2	2	2	2	2168078-1	SCREW, DRIVE, RH, RoHS, 2 x .188	66
-	1	1	1	1	2-1901681-6	HOLDDOWN, TERMINAL	65
-	1	1	1	1	2168083-2	SCR, SKT HD CAP, RoHS, M4 X 8.0	60
-	1	1	1	1	5-18022-5	SCR, HEX HD CAP, M4 X 6.0	59
-	-	1	-	1	2063961-1	FEED FINGER	58
-	4	4	4	4	2168400-4	SHCS, LOW HEAD, RoHS, M4 X 8	57
-	2	2	2	2	2168083-2	SCR, SKT HD CAP, RoHS, M4 X 8.0	56
-	2	2	2	2	5018030-1	NUT, HEX, REG, RoHS, M3	54
-	2	2	2	2	986965-8	NUT, LOCK, HEX, TORQUE (M4)	53
-	1	1	1	1	1-5018030-0	NUT, HEX, REG, RoHS, M3.5	52
-	1	-	1	-	1-2063961-0	FEED FINGER	51
-	1	2	1	2	18023-9	SCR, SKT HD CAP M4 X 6.0	49
-	-	1	-	1	2119652-1	FEED CAM, PRE FEED	48
-	-	1	-	1	2119653-1	FEED CAM, POST FEED	47
-	1	1	1	1	2119655-5	APPLICATOR BASIC ASSEMBLY, EF	46
-	1	1	1	1	1803517-1	RAM ASSEMBLY, EF ATLANTIC	44
-	1	1	1	1	1803602-1	SCR, BHSC, RoHS (M8 X 25)	41
-	8	8	8	8	1-18028-2	WASHER, FLAT, REG M4	33
-	2	2	2	2	2168083-9	SCR, SKT HD CAP, RoHS, M4 X 20	31
-	2	2	2	2	2168083-2	SCR, SKT HD CAP, RoHS, M4 X 8.0	29
-	1	1	1	1	240639-3	STRIPPER (MACHINING)	27
-	2	2	2	2	1-2168083-5	SCR, SKT HD CAP, RoHS, M4 X 30	25
-	1	1	1	1	1752371-5	PLATE, STRIP GUIDE	24
-	2	2	2	2	2-22281-3	SPRING, COMPRESSION	22
-	1	1	1	1	1803292-4	DRAG	20
-	1	1	1	1	4-1901696-9	STRIP GUIDE, REAR	19
-	1	1	1	1	5-1901695-0	STRIP GUIDE, FRONT	18
-	4	4	4	4	1-2079383-1	SCR, BHSC, RoHS (M6 X 12)	17
-	1	1	1	1	240644-1	PLATE, REAR SHEAR	11
-	2	2	2	2	240645-9	SPACER, SHEAR PLATE	10
-	1	1	1	1	4-690482-4	PLATE, FRONT SHEAR	9
1	2	2	1	1	3-1803059-0	ANVIL, COMBINATION, END FEED	8
-	1	1	1	1	8-240651-9	BLADE, SLUG	7
-	-	-	-	-	-	-	6
-	1	1	1	1	5-240641-9	SPACER	5
-	1	1	1	1	238011-7	BLOCK, CRIMPER SPACER	4
1	2	2	1	1	3-2119784-0	CRIMPER, INSULATION O PREMIUM	3
-	1	1	1	1	455888-8	SPACER, CRIMPER	2
1	2	2	1	1	3-1803188-8	CRIMPER, WIRE	1

DIMENSIONS:		TOLERANCES UNLESS OTHERWISE SPECIFIED:		MATERIAL:	
mm	0 PLC ±	1 PLC ±	2 PLC ±	3 PLC ±	4 PLC ±
	ANGLES	FINISH			

ITEM NO	PART NO	DESCRIPTION
-77-72-71-2-1		

OWN	DATE	NAME
B. WEAVER	24SEP2015	
T. ELBIN	24SEP2015	
T. ELBIN	24SEP2015	

SIZE	CAGE CODE	DRAWING NO	RESTRICTED TO
A1	00779	2150625	

Customer Accessible Production Drawing SCALE 1:1 SHEET 1 OF 4 REV B

LOC	DIST	REV	DESCRIPTION	DATE	OWN	APVD
A	66		SEE SHEET 1			

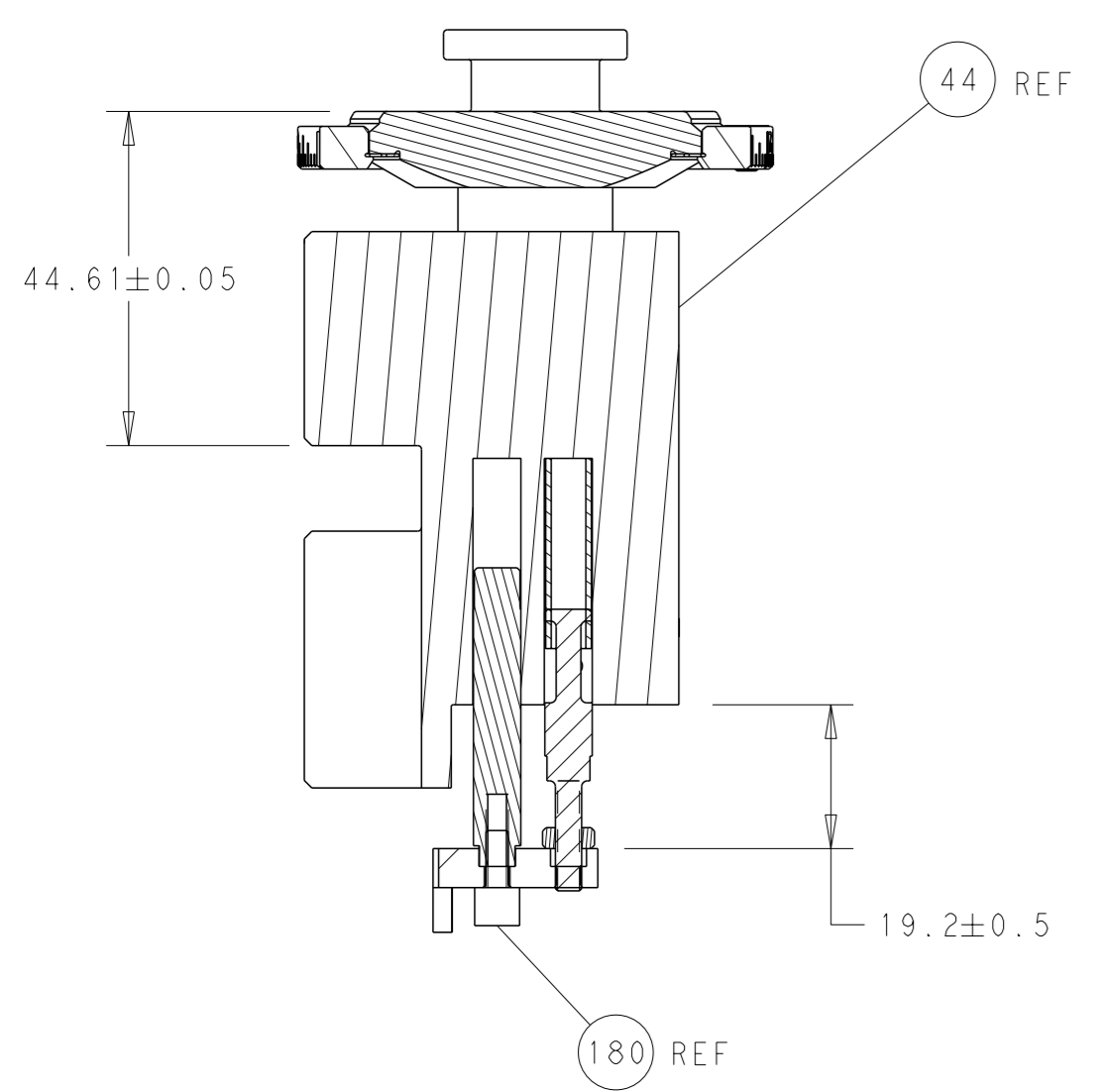

RAM AND HOLDDOWN SET-UP

FEED TYPE
MECHANICAL

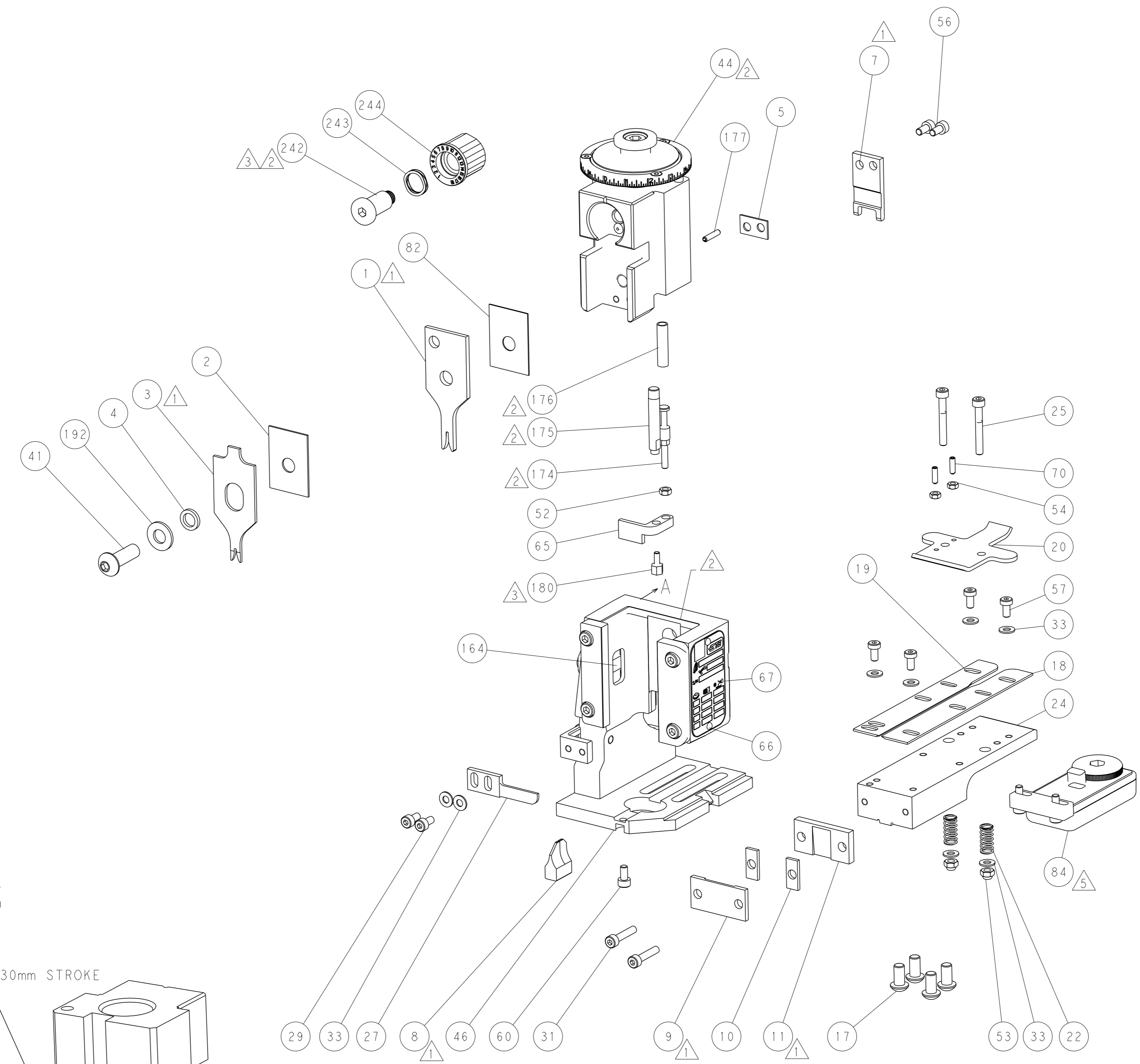
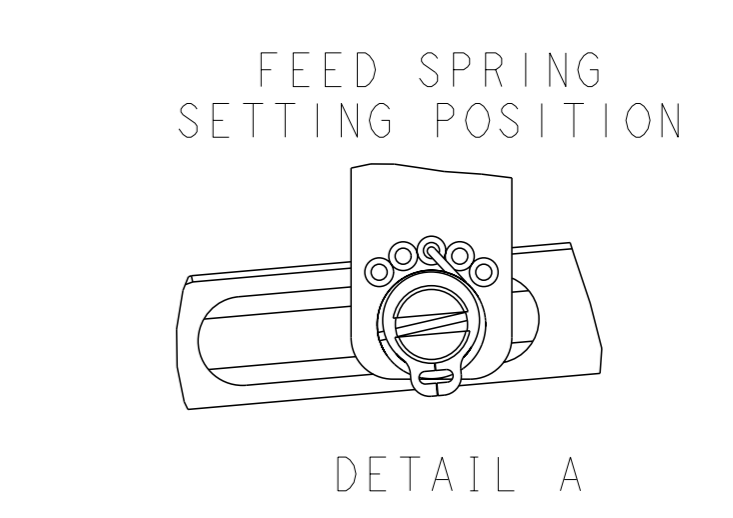
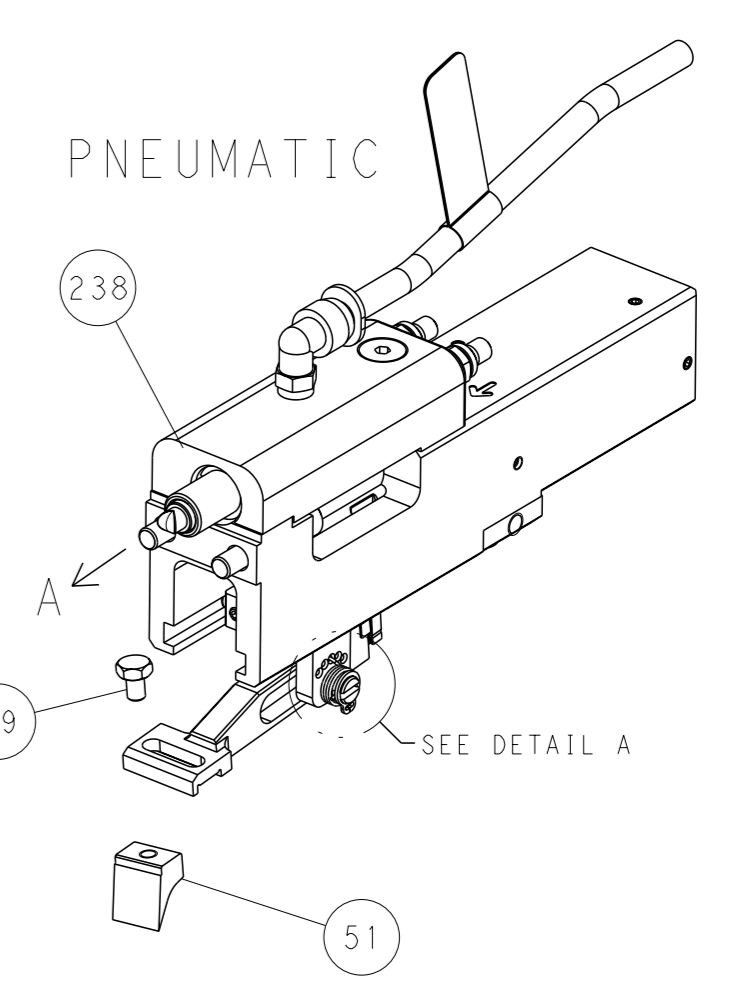
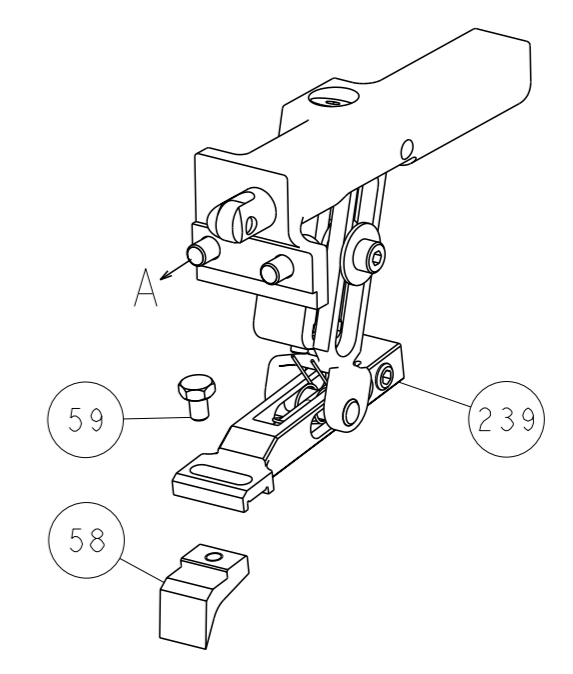

CAM POSITIONS

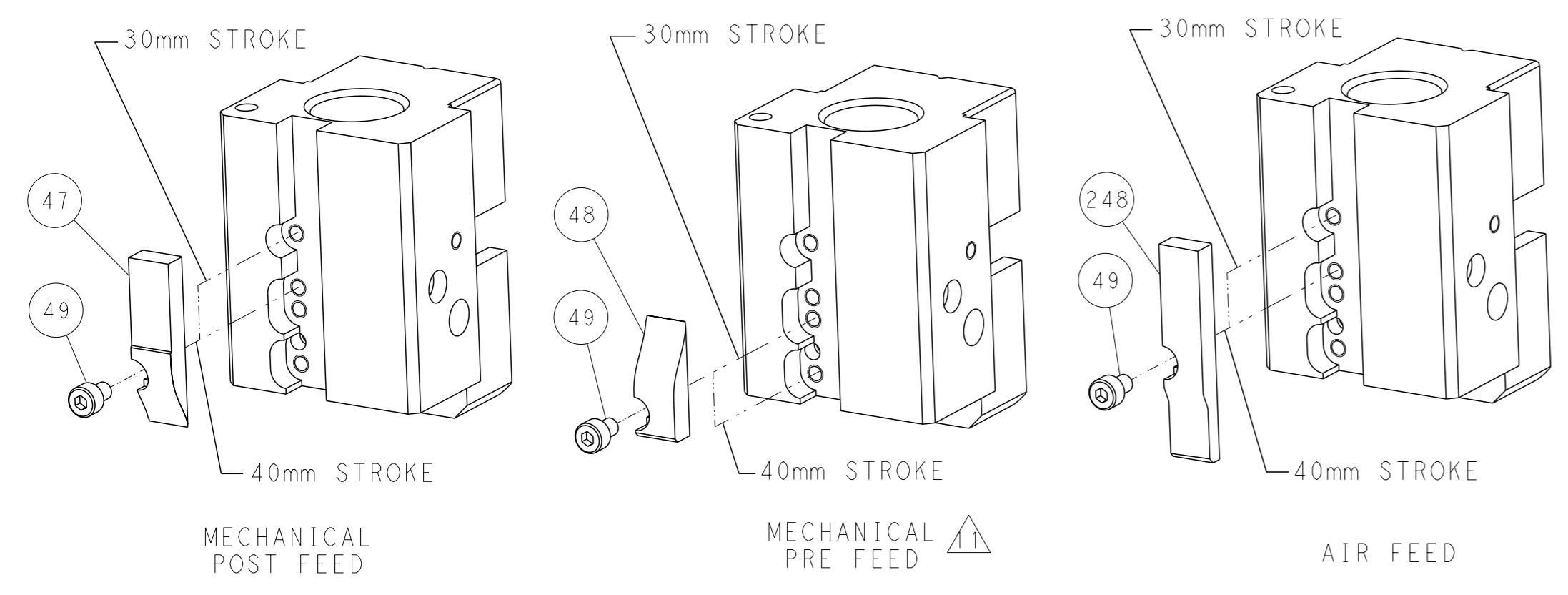

ATLANTIC VERSION
 Shown on sheets 1 of 4 & 2 of 4
 (Pacific version shown on sheets 3 of 4 & 4 of 4)

DIMENSIONS: mm 		TOLERANCES UNLESS OTHERWISE SPECIFIED: 0 PLC ± 1 PLC ± 2 PLC ± 3 PLC ± 4 PLC ± ANGLES ° ±		OWN B. WEAVER 24SEP2015 CHK T. ELBIN 24SEP2015 APVD T. ELBIN 24SEP2015 PRODUCT SPEC APPLICATION SPEC WEIGHT MATERIAL		NAME Ocean End Feed Applicator SIZE CAGE CODE DRAWING NO. RESTRICTED TO A1 00779 ©=2150625 Customer Accessible Production Drawing SCALE 1:1 SHEET 2 of 4 REV B	
-----------------------	--	---	--	--	--	---	--

THIS DRAWING IS UNPUBLISHED.	RELEASED FOR PUBLICATION	2015	
COPYRIGHT 2015 BY TYCO ELECTRONICS CORPORATION. ALL RIGHTS RESERVED.			
PART NUMBER	REVISION	DESCRIPTION	FEED TYPE
2-2150625-1	B	FINE CRIMP HEIGHT ADJUST	MECHANICAL
2-2150625-2	B	FINE CRIMP HEIGHT ADJUST	PNEUMATIC
7-2150625-7	A	CRIMP TOOLING KIT	-

PACIFIC VERSION TERMINATOR
INTERFACE ADAPTER

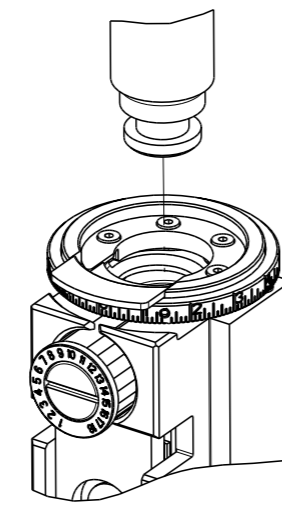

APPLICATOR DATA		
CRIMP	SIZE	TYPE
WIRE	1.27 mm [.050]	F
INSUL	1.40 mm [.055]	O
APPL INSTRUCTIONS 408-35043		

TERMINAL DATA: FCI TERMINAL		TE CRIMP SPECIFICATION
TERMINAL NAME: TERMINAL, CTW MINI PV SMALL INSULATION		
WIRE STRIP LENGTH 3.74-4.50 mm [.147-.177 IN]	INSULATION DIAMETER RANGE Ø 0.51-1.14 mm [.020-.045 IN]	
TERMINAL APPLICATION SPECIFICATION	NONE	-

TERMINALS APPLIED			
TE TERMINAL	FCI TERMINAL	TE TERMINAL	FCI TERMINAL
2113909-1	75231-013	2113909-6	75231-027
2113909-2	75231-014	2113909-7	75231-030
2113909-3	75231-015	2113909-8	75231-031
2113909-4	75231-025	2113909-9	75231-032
2113909-5	75231-026		

WIRE SIZE	CRIMP HEIGHT mm [INCH]	CRIMP HEIGHT REFERENCE SETTING
22 AWG	0.95 +/- 0.05 [.037 +/- .002]	7.7
24 AWG	0.86 +/- 0.05 [.034 +/- .002]	8.8
26 AWG	0.81 +/- 0.05 [.032 +/- .002]	9.3

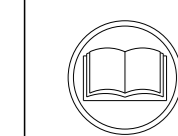

- 1 RECOMMENDED SPARE PARTS
- 2 REFER TO SUPPLIED INSTRUCTION SHEET FOR CLEANING, LUBRICATION AND STORAGE OF APPLICATOR.
- 3 APPLY PART NUMBER 1-23419-5 LOCTITE TO THREADS OF ITEM 180. APPLY PART NUMBER 2-23419-6 LOCTITE TO THREADS OF ITEM 242.
- 4 CRIMP HEIGHT REFERENCE SETTING WAS THE SETTING USED WHEN THE APPLICATOR WAS QUALIFIED AT THE FACTORY. ADJUSTMENT MAY BE NECESSARY WHEN RUNNING APPLICATOR IN THE FIELD.
- 5 TERMINAL LUBRICANT IS RECOMMENDED.
- 6. UNLESS SPECIFIED OTHERWISE TORQUE VALUES SHALL BE USED PER DOCUMENT, 101-35000.

***WARNING**
ON INSTALLATION, SET WIRE DISC TO CRIMP HEIGHT REFERENCE SETTING FOR LARGEST WIRE SIZE. CRIMP HEIGHT REFERENCE SETTINGS GREATER THAN THE VALUE SHOWN MAY CAUSE DAMAGE TO THE CRIMP TOOLING, REFER TO THE INSTRUCTION SHEET FOR PROPER SETUP AND ADJUSTMENTS.

PACIFIC VERSION
Shown on sheets 3 of 4 & 4 of 4
(Atlantic version shown on sheets 1 of 4 & 2 of 4)

LOC	DIST	REVISIONS					
A	66	P	LYR	DESCRIPTION	DATE	OWN	APVD
		-		SEE SHEET 1	-	-	-

-	1	1	2119082-5	CAM, SNAIL, INSULATION ADJUSTMENT	244
-	1	1	2079764-1	WASHER, WAVE SPRING, CREST-TO-CREST	243
3	-	1	2119083-1	RETAINER, INSULATION DIAL	242
-	-	1	2119580-1	MECHANICAL FEED ASSEMBLY	239
-	1	-	2844940-3	AIR FEED MODULE	238
-	1	1	1-18028-0	WASHER, FLAT, REG M8	192
-	4	4	2079383-9	SCR, BHSC, RoHS (M6 X 20)	186
3	-	1	1752354-5	STANDOFF, HOLD-DOWN	180
-	1	1	6-993111-6	PIN, SLOTTED SPRING 3.0 X 14.0	177
-	1	1	8-22280-7	SPRING, COMPRESSION	176
-	1	1	1752353-2	GUIDE PIN, HOLDDOWN	175
-	1	1	1901680-2	GUIDE PIN, HOLDDOWN	174
-	REF	REF	994970-2	COUNTER, MAGNETIC	164
-	1	-	2119641-2	FEED CAM, AIR FEED	152
-	1	1	2168083-8	SCR, SKT HD CAP, RoHS, M4 X 16	144
-	-	1	2119653-2	FEED CAM, POST FEED	142
-	1	1	2119655-6	APPLICATOR BASIC ASSEMBLY, EF	141
-	1	1	1803518-1	RAM ASSEMBLY, EF PACIFIC	140
5	-	1	2119955-2	ASSY, LUBRICATOR, END FEED	84
-	1	1	455888-5	SPACER, CRIMPER	82
-	1	1	1803607-4	DOCUMENTATION PACKAGE	71
-	2	2	2-18032-2	SCR, SET, FLT PNT, M3 X 10.0	70
-	1	1	2119740-1	TAG, IDENTIFICATION	67
-	2	2	2168078-1	SCREW, DRIVE, RH, RoHS, 2 x .188	66
-	1	1	2-1901681-6	HOLDDOWN, TERMINAL	65
-	1	1	5-18022-5	SCR, HEX HD CAP, M4 X 6.0	59
-	-	1	2063961-1	FEED FINGER	58
-	4	4	2168400-4	SHCS, LOW HEAD, RoHS, M4 X 8	57
-	2	2	2168083-2	SCR, SKT HD CAP, RoHS, M4 X 8.0	56
-	2	2	5018030-1	NUT, HEX, REG, RoHS, M3	54
-	2	2	986965-8	NUT, LOCK, HEX, TORQUE (M4)	53
-	1	1	1-5018030-0	NUT, HEX, REG, RoHS, M3.5	52
-	1	-	1-2063961-0	FEED FINGER	51
-	1	2	18023-9	SCR, SKT HD CAP M4 X 6.0	49
-	-	1	2119652-1	FEED CAM, PRE FEED	48
-	1	1	1803602-1	SCR, BHSC, RoHS (M8 X 25)	41
-	8	8	1-18028-2	WASHER, FLAT, REG M4	33
-	2	2	2168083-9	SCR, SKT HD CAP, RoHS, M4 X 20	31
-	2	2	2168083-2	SCR, SKT HD CAP, RoHS, M4 X 8.0	29
-	1	1	240639-3	STRIPPER (MACHINING)	27
-	2	2	1-2168083-5	SCR, SKT HD CAP, RoHS, M4 X 30	25
-	1	1	1752371-5	PLATE, STRIP GUIDE	24
-	2	2	2-22281-3	SPRING, COMPRESSION	22
-	1	1	1803292-4	DRAG	20
-	1	1	4-1901696-9	STRIP GUIDE, REAR	19
-	1	1	5-1901695-0	STRIP GUIDE, FRONT	18
-	1	1	1752360-1	SPACER, HOLD-DOWN	13
1	-	1	240644-1	PLATE, REAR SHEAR	11
1	-	2	240645-9	SPACER, SHEAR PLATE	10
1	-	1	4-690482-4	PLATE, FRONT SHEAR	9
1	1	1	3-1803059-0	ANVIL, COMBINATION, END FEED	8
1	-	1	8-240651-9	BLADE, SLUG	7
-	-	-	-	-	6
-	1	1	5-240641-9	SPACER	5
-	1	1	238011-7	BLOCK, CRIMPER SPACER	4
1	1	1	3-2119784-0	CRIMPER, INSULATION O PREMIUM	3
-	1	1	455888-8	SPACER, CRIMPER	2
1	1	1	3-1803188-8	CRIMPER, WIRE	1

THE DRAWING IS CONTROLLED BY THE DRAWING CONTROL AND REVISIONS DEPARTMENT. IT IS SUBJECT TO CHANGE AND THE CONTROL AND REVISIONS DEPARTMENT SHOULD BE CONTACTED FOR THE LATEST REVISION.		OWN B. WEAVER 24SEP2015	TE Connectivity Harrisburg, PA 17105-3608
DIMENSIONS: mm		CHK T. ELBIN 24SEP2015	NAME Ocean End Feed Applicator
TOLERANCES UNLESS OTHERWISE SPECIFIED: 0 PLC ± 1 PLC ± 2 PLC ± 3 PLC ± 4 PLC ± ANGLES ±		APVD T. ELBIN 24SEP2015	SIZE A1
MATERIAL		APPLICATION SPEC	SCALE 1:1
		WEIGHT	SHEET 3 of 4
		FINISH	REV B
		Customer Accessible Production Drawing	Customer Accessible Production Drawing

LOC	DIST	REVISIONS			
		REV	DATE	OWN	APVD
A	66	1	SEE SHEET 1	-	-

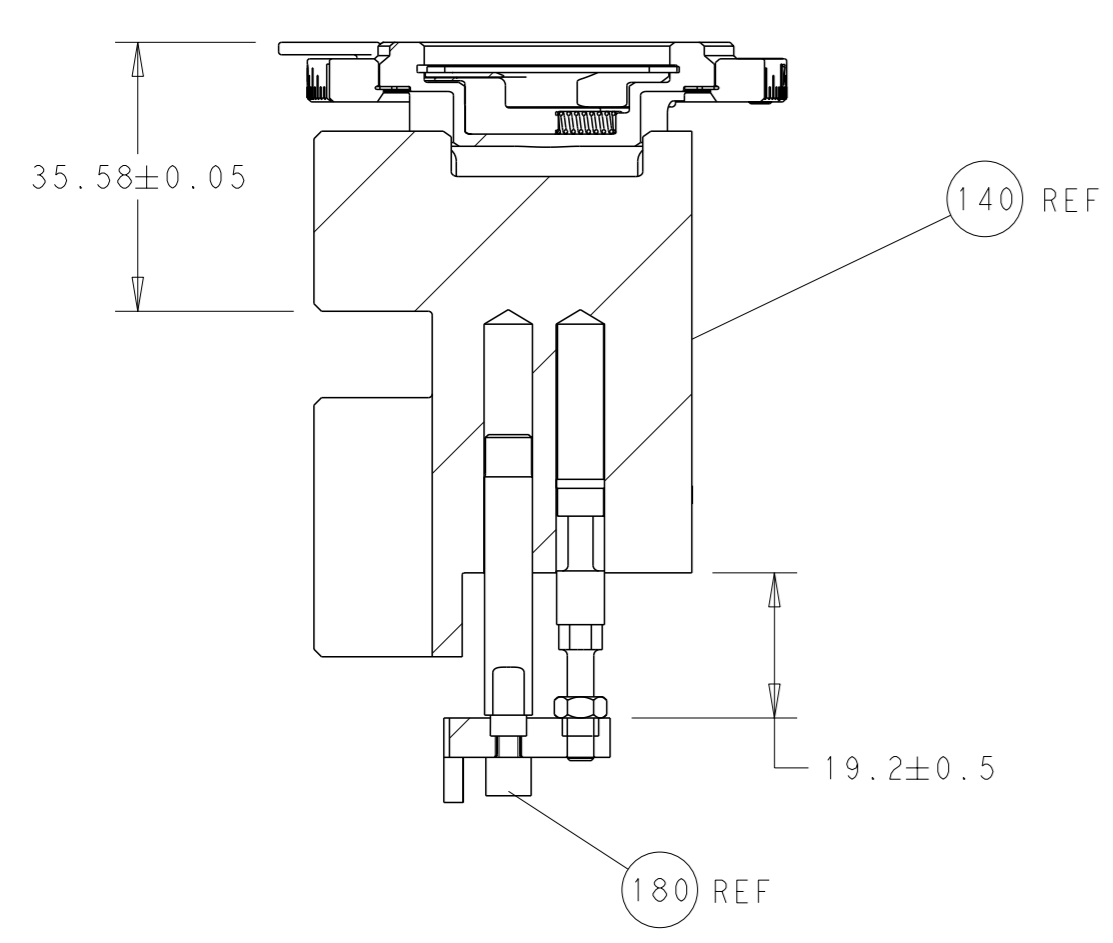

RAM AND HOLDDOWN SET-UP

FEED TYPE
MECHANICAL

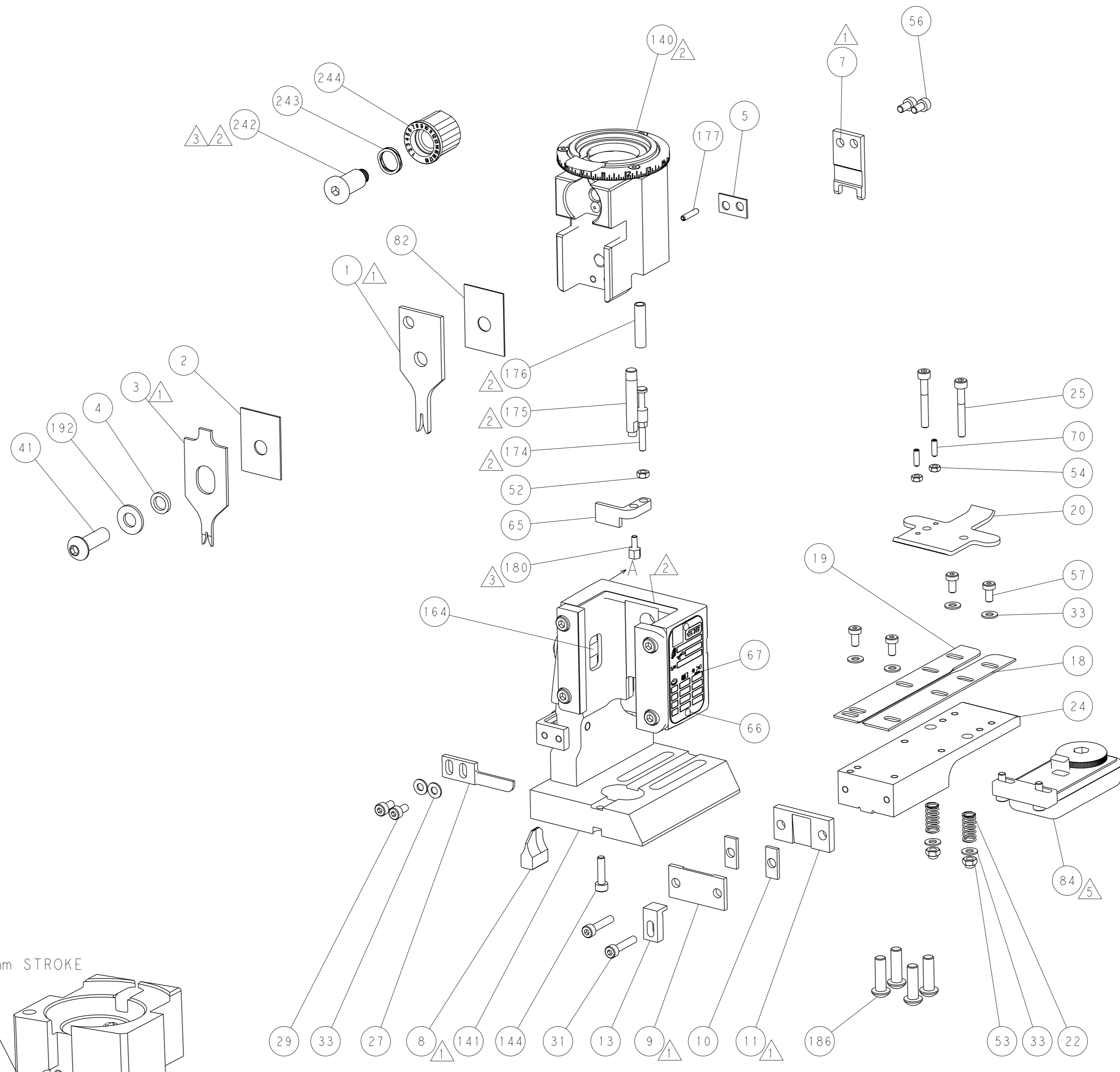
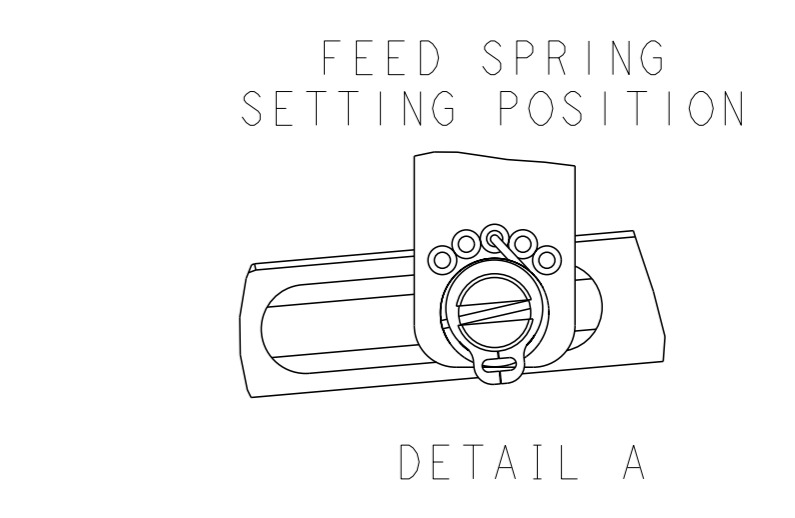
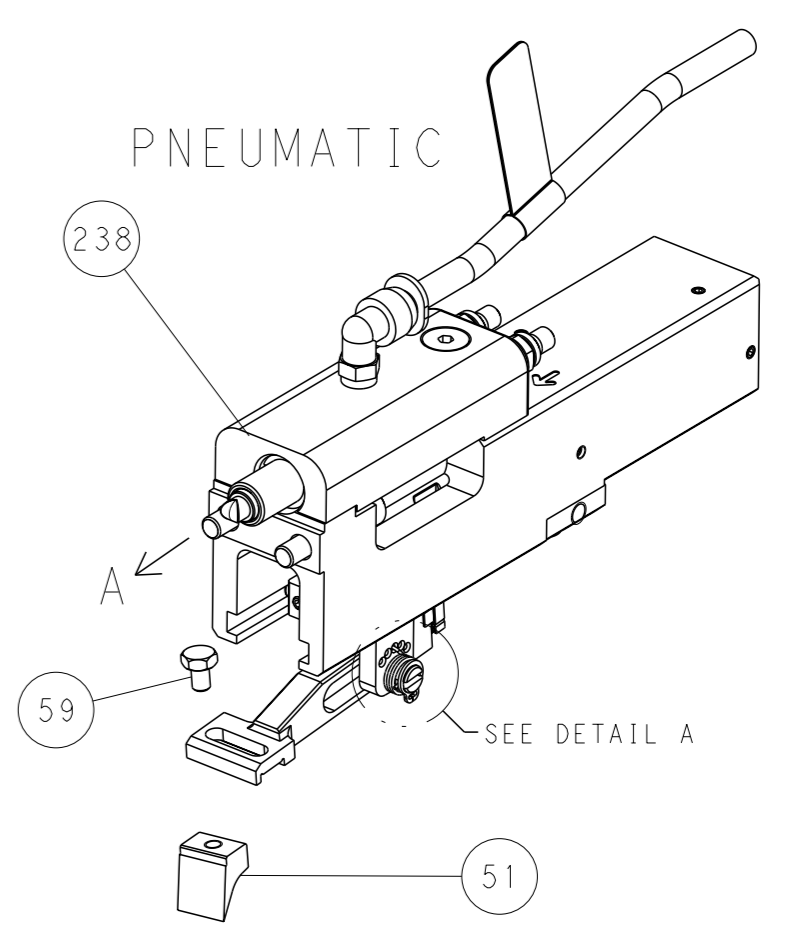
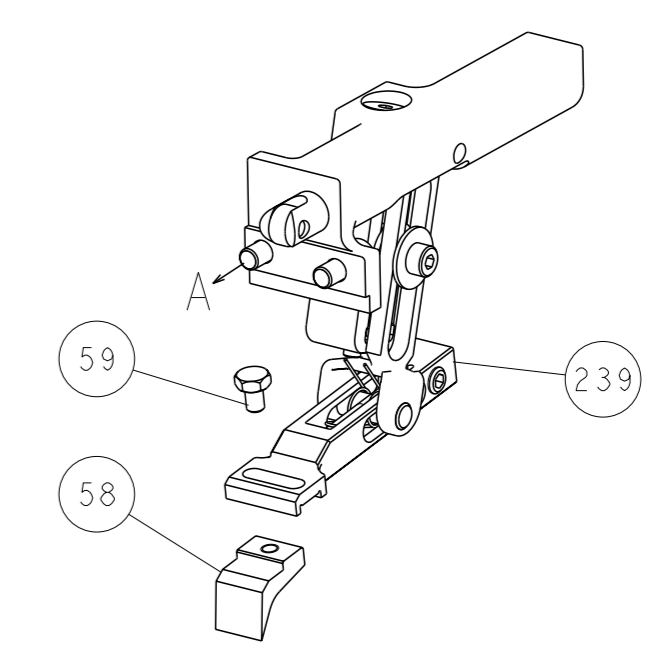

CAM POSITIONS

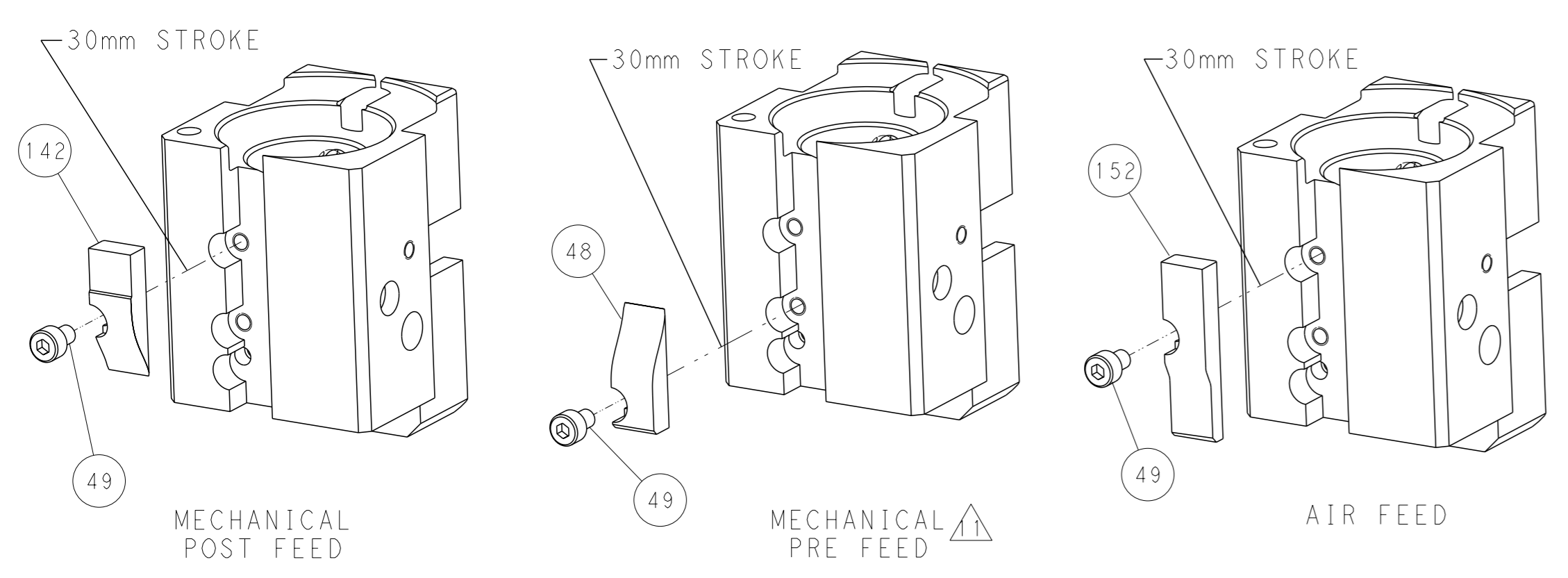

PACIFIC VERSION
 Shown on sheets 3 of 4 & 4 of 4
 (Atlantic version shown on sheets 1 of 4 & 2 of 4)

<small>THIS DRAWING IS UNPUBLISHED. RELEASED FOR PUBLICATION 2015 BY TYCO ELECTRONICS CORPORATION. ALL RIGHTS RESERVED.</small>		OWN: B. WEAVER CHK: T. ELBIN APVD: T. ELBIN	DATE: 24SEP2015 DATE: 24SEP2015 DATE: 24SEP2015	NAME: Ocean End Feed Applicator SCALE: 1:1	SHEET: 4 of 4 REV: B
DIMENSIONS: mm TOLERANCES UNLESS OTHERWISE SPECIFIED: 0 PLC ± 1 PLC ± 2 PLC ± 3 PLC ± 4 PLC ± ANGLES FINISH ±	MATERIAL:	WEIGHT:	SIZE: A1 CAGE CODE: 00779 DRAWING NO: C=2150625	RESTRICTED TO:	CUSTOMER ACCESSIBLE PRODUCTION DRAWING