

MODEL G3QANT - DIRECT-MOUNT AND PANEL-MOUNT GSM/ GPRS MULTI - BAND ANTENNAS



ORDERING INFORMATION

MODEL NO.	DESCRIPTION	PART NUMBER
G3QANT	Direct-mount GSM/GPRS Antenna	G3QANT00
	Panel-mount GSM/GPRS Antenna	G3QANTPM

G3QANT00 - DIRECT-MOUNT GSM/ GPRS ANTENNA

DESCRIPTION

For use with the G3GSM or XCGSM Cellular Modem Option Cards, this antenna mounts directly to the connector on the option card itself. In most cases, this antenna will provide a strong and continuous cellular signal. For installations where cell signal is weak or intermittent, a remotely-located panel-mount antenna is available.

SPECIFICATIONS

- FREQUENCY:** Quad-band 850 MHz, 900 MHz, 1.8 GHz and 1.9 GHz operation
- RADIATION PATTERN:** Omni directional
- MOUNTING METHOD:** 90° swivel mount
- CONNECTOR:** SMA connector
- PEAK GAIN:** 0dBi gain
- IMPEDANCE:** 50 Ohm
- HOUSING:** Polycarbonate housing

INSTALLATION

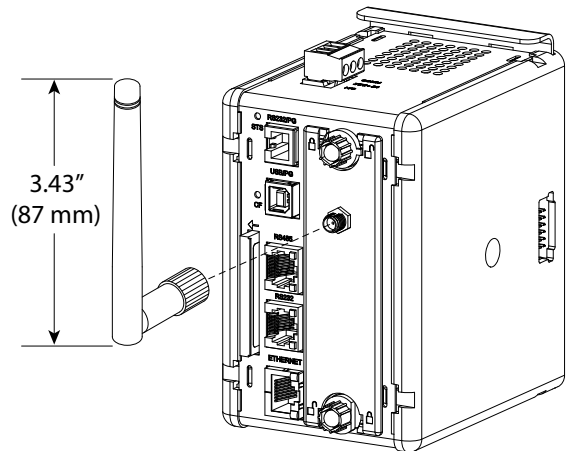
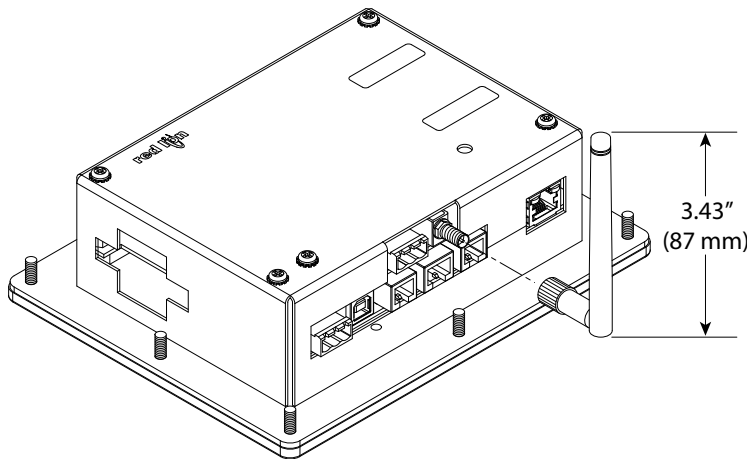

G3QANTPM PANEL-MOUNT GSM/ GPRS ANTENNA

DESCRIPTION

For use with the G3GSM or XCGSM Cellular Modem Option Cards, this panel-mount antenna will allow remote mounting outside of a control cabinet* to assist in maintaining high and continuous cellular signal strength. The engineering plastic case around the antenna forms a watertight seal at its base.

* To maintain the UL listing of the base unit, for example an HMI, the remote antenna must still be mounted indoors or in a UL certified enclosure suitably rated for the application.

SPECIFICATIONS

1. **FREQUENCY:** Dual-band 824-896/1710-1990 MHz operation
2. **V.S.W.R.:** $\leq 1.5:1$
3. **RADIATION PATTERN:** Omni directional
4. **MOUNTING METHOD:** Screw-mount watertight seal (no gasket required)
5. **CONNECTOR:** SMA connector
6. **PEAK GAIN:** 2~3.5 dBi
7. **IMPEDANCE:** 50 Ohm
8. **CABLE:** Provided with 6' cable and mounting hardware
9. **HOUSING:** Black engineering plastic housing
10. **DIMENSIONS:** 3.74" (95 mm) high; 1.10" (28 mm) dia. base

INSTALLATION

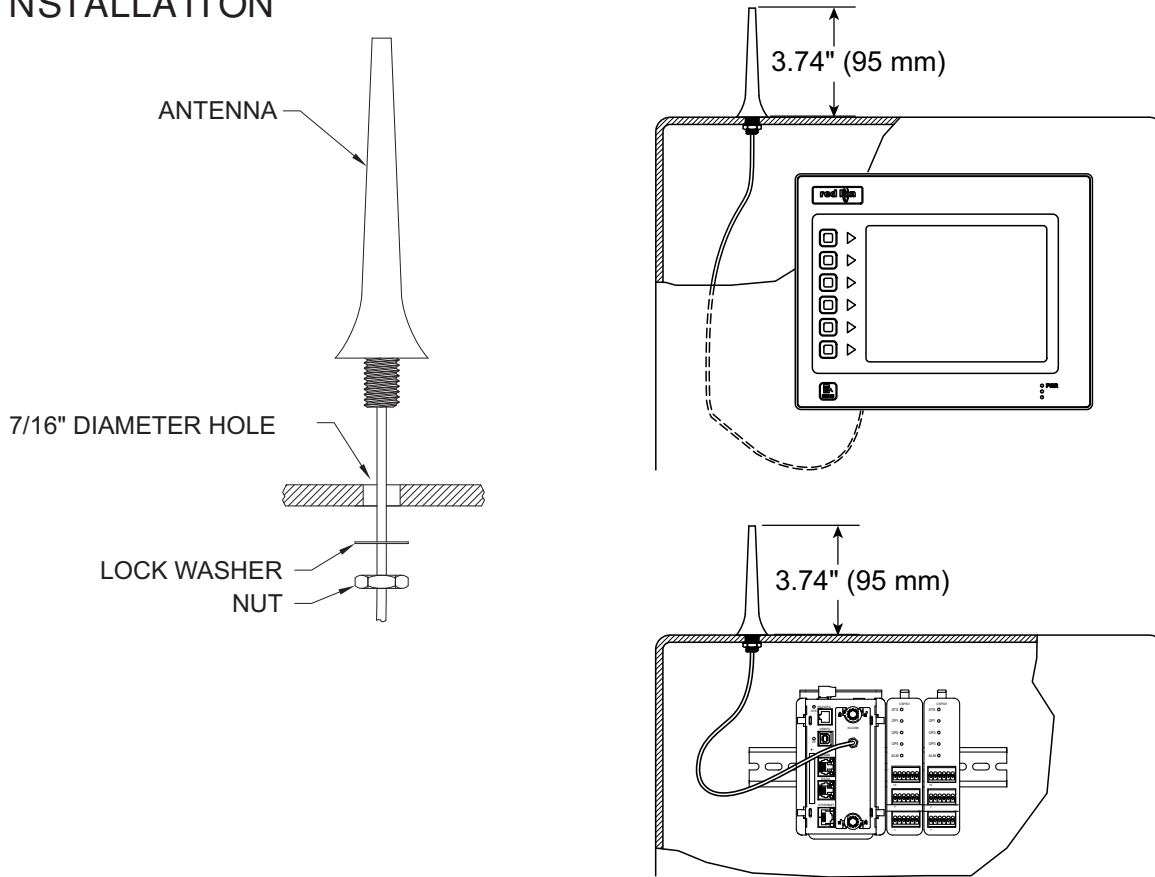

LIMITED WARRANTY

The Company warrants the products it manufactures against defects in materials and workmanship for a period limited to two years from the date of shipment, provided the products have been stored, handled, installed, and used under proper conditions. The Company's liability under this limited warranty shall extend only to the repair or replacement of a defective product, at The Company's option. The Company disclaims all liability for any affirmation, promise or representation with respect to the products.

The customer agrees to hold Red Lion Controls harmless from, defend, and indemnify RLC against damages, claims, and expenses arising out of subsequent sales of RLC products or products containing components manufactured by RLC and based upon personal injuries, deaths, property damage, lost profits, and other matters which Buyer, its employees, or sub-contractors are or may be to any extent liable, including without limitation penalties imposed by the Consumer Product Safety Act (P.L. 92-573) and liability imposed upon any person pursuant to the Magnuson-Moss Warranty Act (P.L. 93-637), as now in effect or as amended hereafter.

No warranties expressed or implied are created with respect to The Company's products except those expressly contained herein. The Customer acknowledges the disclaimers and limitations contained herein and relies on no other warranties or affirmations.

Red Lion Controls
Headquarters
20 Willow Springs Circle
York PA 17406
Tel +1 (717) 767-6511
Fax +1 (717) 764-0839

Red Lion Controls
Europe
Printerweg 10
NL - 3821 AD Amersfoort
Tel +31 (0) 334 723 225
Fax +31 (0) 334 893 793

Red Lion Controls
India
54, Vishvas Tenement
GST Road, New Ranip,
Ahmedabad-382480 Gujarat, India
Tel +91 987 954 0503
Fax +91 79 275 31 350

Red Lion Controls
China
Unit 101, XinAn Plaza
Building 13, No.99 Tianzhou Road
Shanghai, P.R. China 200223
Tel +86 21 6113-3688
Fax +86 21 6113-3683