

LM2900/LM3900/LM3301 Quad Amplifiers

General Description

The LM2900 series consists of four independent, dual input, internally compensated amplifiers which were designed specifically to operate off of a single power supply voltage and to provide a large output voltage swing. These amplifiers make use of a current mirror to achieve the non-inverting input function. Application areas include: ac amplifiers, RC active filters, low frequency triangle, squarewave and pulse waveform generation circuits, tachometers and low speed, high voltage digital logic gates.

Features

- Wide single supply voltage Range of dual supplies $4 V_{DC}$ to $32 V_{DC}$
 $\pm 2 V_{DC}$ to $\pm 16 V_{DC}$
- Supply current drain independent of supply voltage
- Low input biasing current 30 nA
- High open-loop gain 70 dB
- Wide bandwidth 2.5 MHz (unity gain)
- Large output voltage swing $(V^+ - 1)$ Vp-p
- Internally frequency compensated for unity gain
- Output short-circuit protection

Schematic and Connection Diagrams

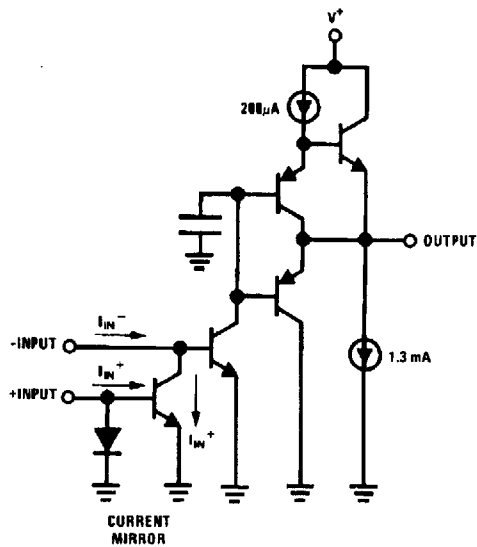

TL/H/7936-1

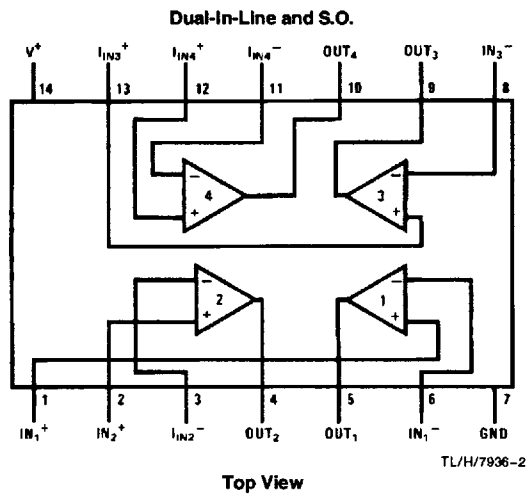

Order Number LM2900N, LM3900M, LM3900N or LM3301N
See NS Package Number M14A or N14A

LM2900/LM3900/LM3301 Quad Amplifiers

Absolute Maximum Ratings

If Military/Aerospace specified devices are required, please contact the National Semiconductor Sales Office/Distributors for availability and specifications.

	LM2900/LM3900	LM3301
Supply Voltage	32 V _{DC} ± 16 V _{DC}	28 V _{DC} ± 14 V _{DC}
Power Dissipation (T _A = 25°C) (Note 1)		
Molded DIP	1080 mW	1080 mW
S.O. Package	765 mW	
Input Currents, I _N ⁺ or I _N ⁻	20 mA _{DC}	20 mA _{DC}
Output Short-Circuit Duration—One Amplifier T _A = 25°C (See Application Hints)	Continuous	Continuous
Operating Temperature Range		-40°C to +85°C
LM2900	-40°C to +85°C	
LM3900	0°C to +70°C	
Storage Temperature Range	-65°C to +150°C	-65°C to +150°C
Lead Temperature (Soldering, 10 sec.)	260°C	260°C
Soldering Information		
Dual-In-Line Package		
Soldering (10 sec.)	260°C	260°C
Small Outline Package		
Vapor Phase (60 sec.)	215°C	215°C
Infrared (15 sec.)	220°C	220°C
See AN-450 "Surface Mounting Methods and Their Effect on Product Reliability" for other methods of soldering surface mount devices.		
ESD tolerance (Note 7)	2000V	2000V

Electrical Characteristics T_A = 25°C, V⁺ = 15 V_{DC}, unless otherwise stated

Parameter		Conditions	LM2900			LM3900			LM3301			Units	
			Min	Typ	Max	Min	Typ	Max	Min	Typ	Max		
Open Loop	Voltage Gain	Over Temp. ΔV _O = 10 V _{DC} Inverting Input										V/mV	
	Voltage Gain		1.2	2.8		1.2	2.8		1.2	2.8			
	Input Resistance			1			1			1			MΩ
	Output Resistance			8			8			9			kΩ
Unity Gain Bandwidth		Inverting Input		2.5			2.5			2.5		MHz	
Input Bias Current		Inverting Input, V ⁺ = 5 V _{DC} Inverting Input		30	200		30	200		30	300	nA	
Slew Rate		Positive Output Swing Negative Output Swing		0.5 20			0.5 20			0.5 20		V/μs	
Supply Current		R _L = ∞ On All Amplifiers		6.2	10		6.2	10		6.2	10	mA _{DC}	
Output Voltage Swing	V _{OUT} High	R _L = 2k, V ⁺ = 15.0 V _{DC}	I _N ⁻ = 0, I _N ⁺ = 0	13.5			13.5			13.5		V _{DC}	
	V _{OUT} Low				0.09	0.2		0.09	0.2		0.09		0.2
	V _{OUT} High	V ⁺ = Absolute Maximum Ratings	I _N ⁻ = 0, I _N ⁺ = 0 R _L = ∞,	29.5			29.5			26.0			
Output Current Capability	Source			6	18		6	10		5	18	mA _{DC}	
	Sink	(Note 2)		0.5	1.3		0.5	1.3		0.5	1.3		
	I _{SINK}	V _{OL} = 1V, I _N ⁻ = 5 μA			5			5			5		

Electrical Characteristics (Note 6), $V^+ = 15 V_{DC}$, unless otherwise stated (Continued)

Parameter	Conditions	LM2900			LM3900			LM3301			Units
		Min	Typ	Max	Min	Typ	Max	Min	Typ	Max	
Power Supply Rejection	$T_A = 25^\circ\text{C}$, $f = 100\text{ Hz}$		70			70			70		dB
Mirror Gain	@ 20 μA (Note 3) @ 200 μA (Note 3)	0.90 0.90	1.0 1.0	1.1 1.1	0.90 0.90	1.0 1.0	1.1 1.1	0.90 0.90	1 1	1.10 1.10	$\mu\text{A}/\mu\text{A}$
Δ Mirror Gain	@ 20 μA to 200 μA (Note 3)		2	5		2	5		2	5	%
Mirror Current	(Note 4)		10	500		10	500		10	500	μA_{DC}
Negative Input Current	$T_A = 25^\circ\text{C}$ (Note 5)		1.0			1.0			1.0		mA_{DC}
Input Bias Current	Inverting Input		300			300					nA

Note 1: For operating at high temperatures, the device must be derated based on a 125°C maximum junction temperature and a thermal resistance of $92^\circ\text{C}/\text{W}$ which applies for the device soldered in a printed circuit board, operating in a still air ambient. Thermal resistance for the S.O. package is $131^\circ\text{C}/\text{W}$.

Note 2: The output current sink capability can be increased for large signal conditions by overdriving the inverting input. This is shown in the section on Typical Characteristics.

Note 3: This spec indicates the current gain of the current mirror which is used as the non-inverting input.

Note 4: Input V_{BE} match between the non-inverting and the inverting inputs occurs for a mirror current (non-inverting input current) of approximately 10 μA . This is therefore a typical design center for many of the application circuits.

Note 5: Clamp transistors are included on the IC to prevent the input voltages from swinging below ground more than approximately $-0.3 V_{DC}$. The negative input currents which may result from large signal overdrive with capacitance input coupling need to be externally limited to values of approximately 1 mA. Negative input currents in excess of 4 mA will cause the output voltage to drop to a low voltage. This maximum current applies to any one of the input terminals. If more than one of the input terminals are simultaneously driven negative smaller maximum currents are allowed. Common-mode current biasing can be used to prevent negative input voltages; see for example, the "Differentiator Circuit" in the applications section.

Note 6: These specs apply for $-40^\circ\text{C} \leq T_A \leq +85^\circ\text{C}$, unless otherwise stated.

Note 7: Human body model, 1.5 k Ω in series with 100 pF.

Application Hints

When driving either input from a low-impedance source, a limiting resistor should be placed in series with the input lead to limit the peak input current. Currents as large as 20 mA will not damage the device, but the current mirror on the non-inverting input will saturate and cause a loss of mirror gain at mA current levels—especially at high operating temperatures.

Precautions should be taken to insure that the power supply for the integrated circuit never becomes reversed in polarity or that the unit is not inadvertently installed backwards in a test socket as an unlimited current surge through the resulting forward diode within the IC could cause fusing of the internal conductors and result in a destroyed unit.

Output short circuits either to ground or to the positive power supply should be of short time duration. Units can be destroyed, not as a result of the short circuit current causing metal fusing, but rather due to the large increase in IC chip dissipation which will cause eventual failure due to excessive junction temperatures. For example, when operating from a well-regulated $+5 V_{DC}$ power supply at $T_A = 25^\circ\text{C}$ with a 100 k Ω shunt-feedback resistor (from the output to the inverting input) a short directly to the power supply will not cause catastrophic failure but the current magnitude will be approximately 50 mA and the junction temperature will be above T_J max. Larger feedback resistors will reduce the current, 11 M Ω provides approximately 30 mA, an open circuit provides 1.3 mA, and a direct connection from the output to the non-inverting input will result in catastrophic failure when the output is shorted to V^+ as this then places the base-emitter junction of the input transistor directly across the power supply. Short-circuits to ground will have magnitudes of approximately 30 mA and will not cause catastrophic failure at $T_A = 25^\circ\text{C}$.

Unintentional signal coupling from the output to the non-inverting input can cause oscillations. This is likely only in breadboard hook-ups with long component leads and can be prevented by a more careful lead dress or by locating the non-inverting input biasing resistor close to the IC. A quick check of this condition is to bypass the non-inverting input to ground with a capacitor. High impedance biasing resistors used in the non-inverting input circuit make this input lead highly susceptible to unintentional AC signal pickup.

Operation of this amplifier can be best understood by noting that input currents are differenced at the inverting-input terminal and this difference current then flows through the external feedback resistor to produce the output voltage. Common-mode current biasing is generally useful to allow operating with signal levels near ground or even negative as this maintains the inputs biased at $+V_{BE}$. Internal clamp transistors (see note 5) catch-negative input voltages at approximately $-0.3 V_{DC}$ but the magnitude of current flow has to be limited by the external input network. For operation at high temperature, this limit should be approximately 100 μA .

This new "Norton" current-differencing amplifier can be used in most of the applications of a standard IC op amp. Performance as a DC amplifier using only a single supply is not as precise as a standard IC op amp operating with split supplies but is adequate in many less critical applications. New functions are made possible with this amplifier which are useful in single power supply systems. For example, biasing can be designed separately from the AC gain as was shown in the "inverting amplifier," the "difference integrator" allows controlling the charging and the discharging of the integrating capacitor with positive voltages, and the "frequency doubling tachometer" provides a simple circuit which reduces the ripple voltage on a tachometer output DC voltage.

Typical Performance Characteristics

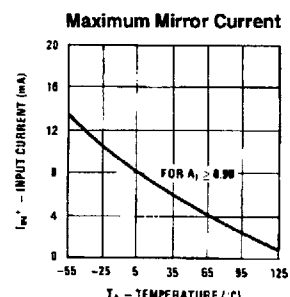
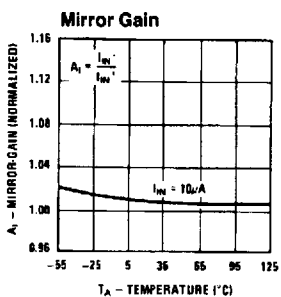
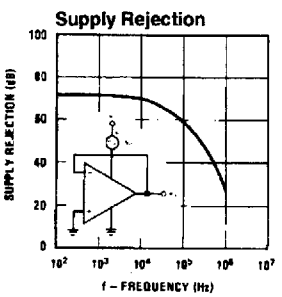
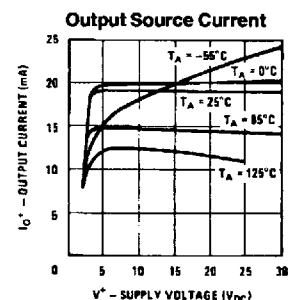
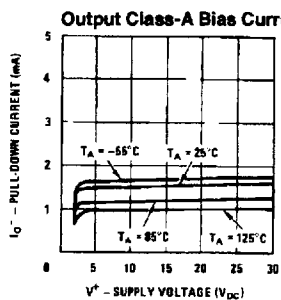
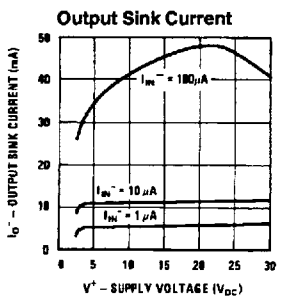
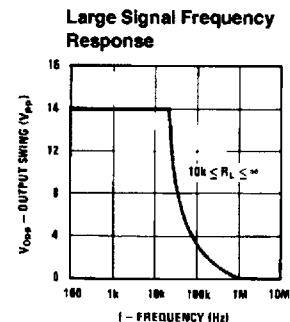
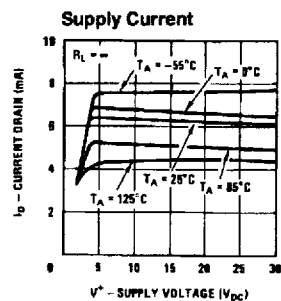
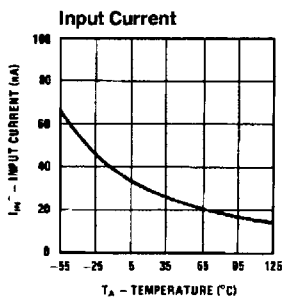
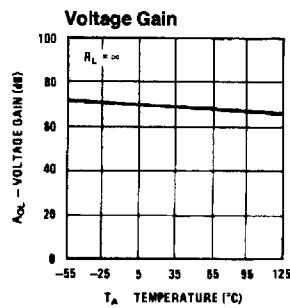
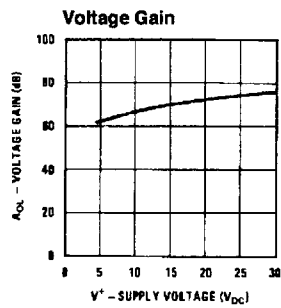
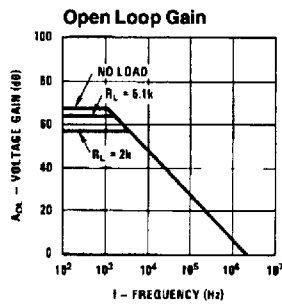

TL/H/7936-9

Typical Applications ($V^+ = 15 V_{DC}$)

Inverting Amplifier

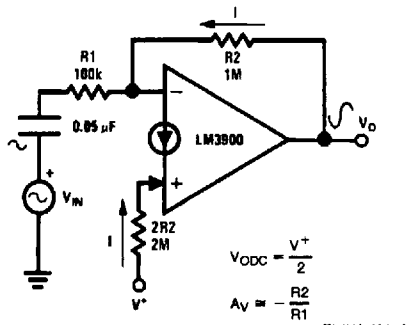

Triangle/Square Generator

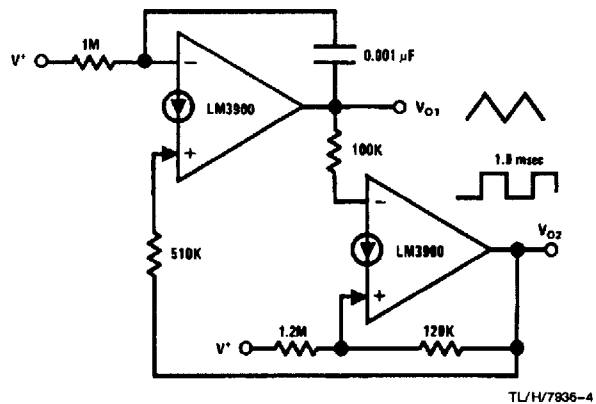

Frequency-Doubling Tachometer

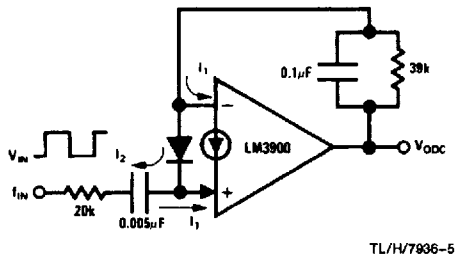

Low $V_{IN} - V_{OUT}$ Voltage Regulator

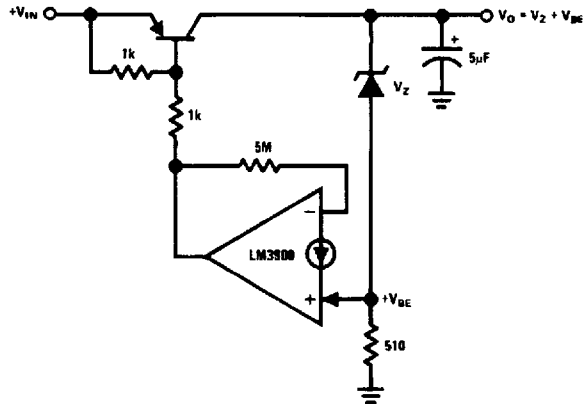

Non-Inverting Amplifier

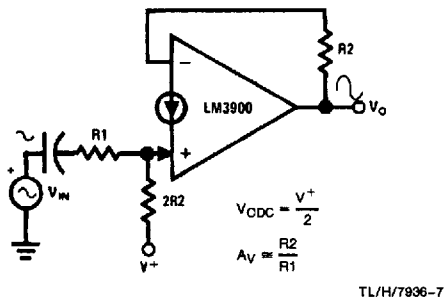

Negative Supply Biasing

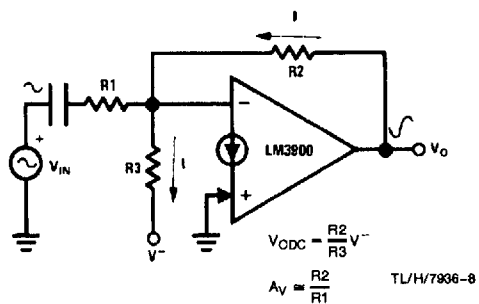

Typical Applications ($V^+ = 15 V_{DC}$) (Continued)

Low-Drift Ramp and Hold Circuit

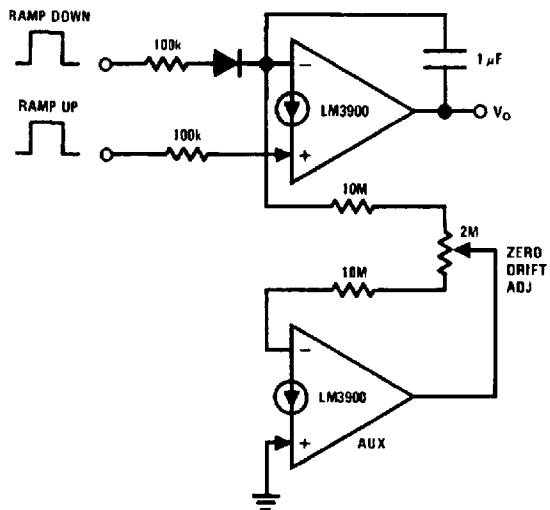

TL/H/7836-10

Bi-Quad Active Filter
(2nd Degree State-Variable Network)

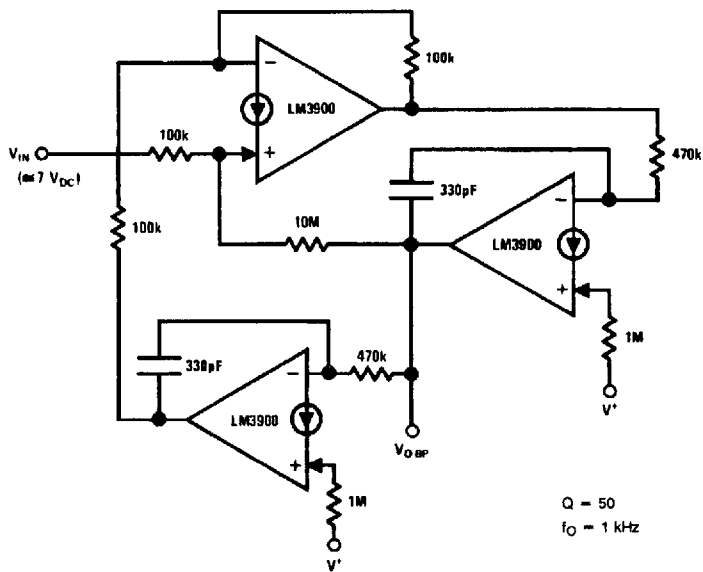

$Q = 50$
 $f_0 = 1 \text{ kHz}$

TL/H/7836-11

Typical Applications ($V^+ = 15\text{ V}_{DC}$) (Continued)

**Voltage-Controlled Current Source
(Transconductance Amplifier)**

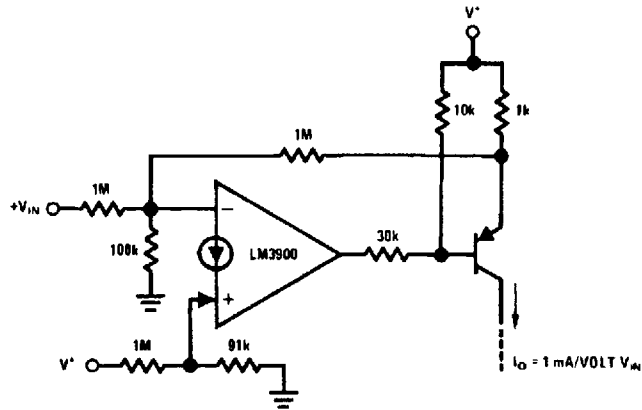

TL/H/7836-12

Hi V_{IN} , Lo ($V_{IN} - V_O$) Self-Regulator

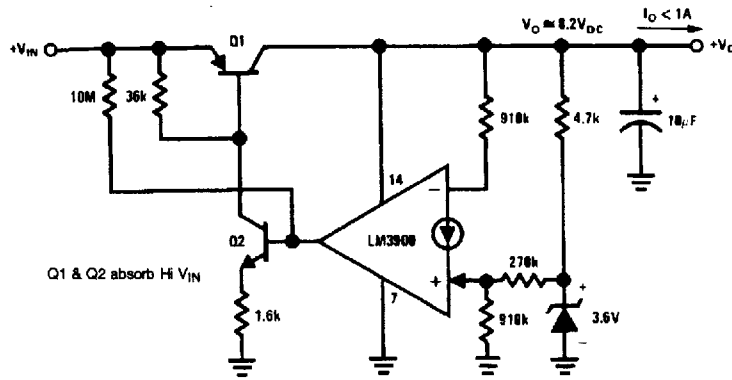

TL/H/7836-13

Ground-Referencing a Differential Input Signal

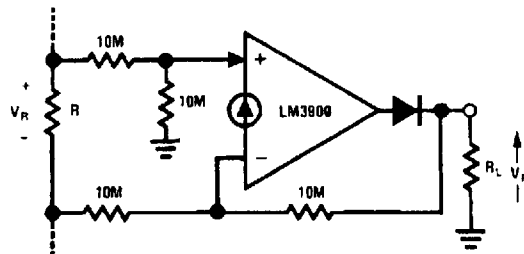

TL/H/7836-14

Typical Applications ($V^+ = 15\text{ V}_{DC}$) (Continued)

Voltage Regulator

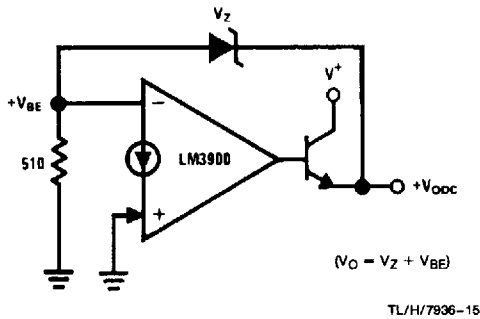

TL/H/7936-15

Fixed Current Sources

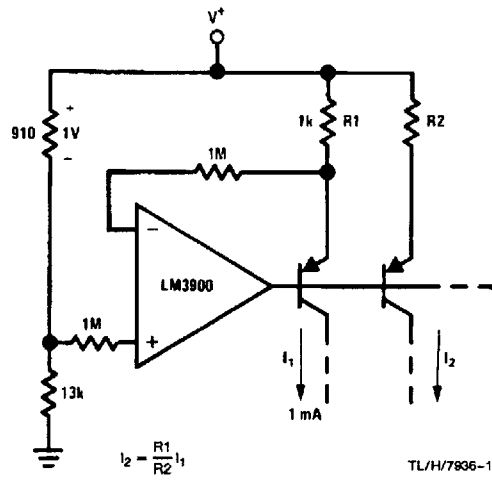

TL/H/7936-16

**Voltage-Controlled Current Sink
(Transconductance Amplifier)**

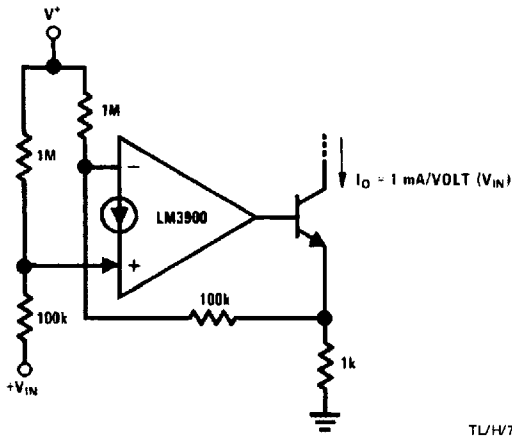

TL/H/7936-17

Buffer Amplifier

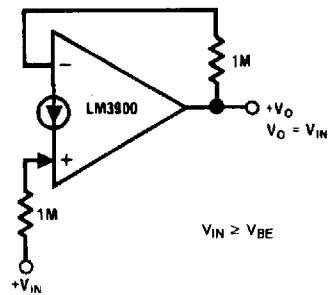

$V_{IN} \geq V_{BE}$

TL/H/7936-18

Tachometer

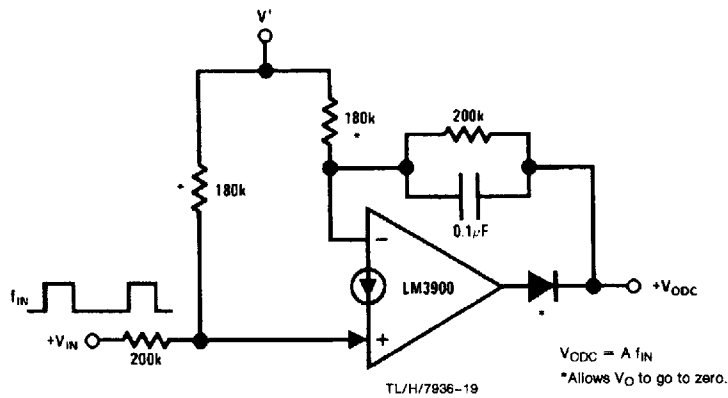

TL/H/7936-19

Typical Applications ($V^+ = 15 V_{DC}$) (Continued)

Low-Voltage Comparator

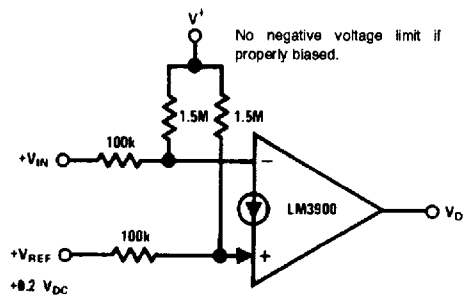

TL/H/7936-20

Power Comparator

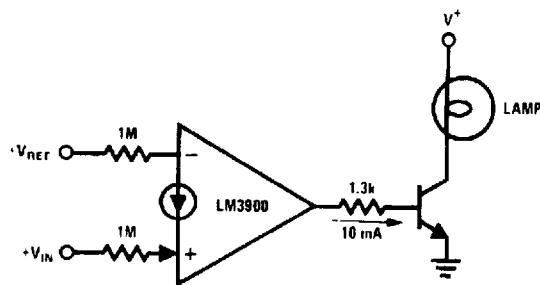

TL/H/7936-21

Comparator

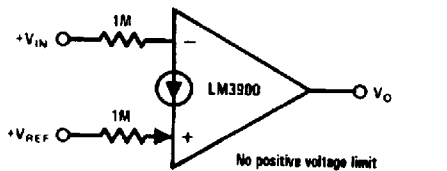

No positive voltage limit
TL/H/7936-22

Schmitt-Trigger

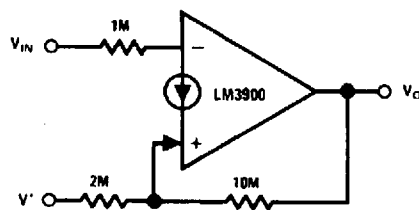

TL/H/7936-23

Square-Wave Oscillator

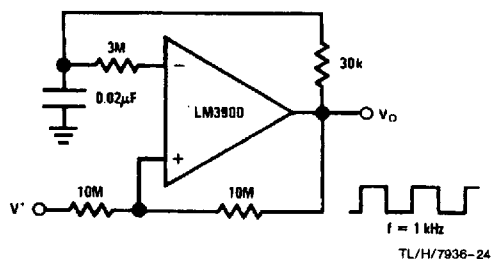

TL/H/7936-24

Pulse Generator

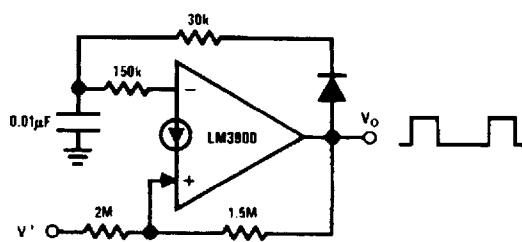

TL/H/7936-25

Frequency Differencing Tachometer

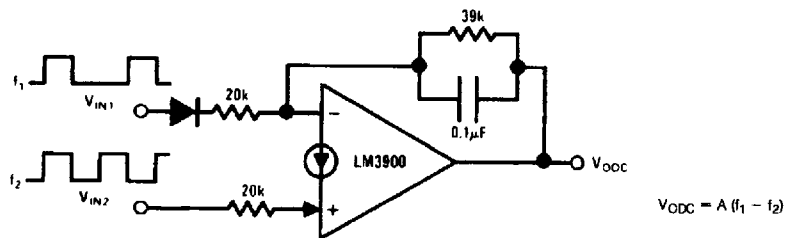

$$V_{OOC} = A(f_1 - f_2)$$

TL/H/7936-26

Typical Applications ($V^+ = 15 V_{DC}$) (Continued)

Frequency Averaging Tachometer

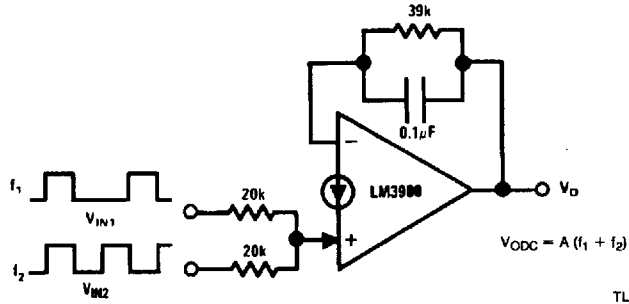

TL/H/7836-27

Squaring Amplifier (W/Hysteresis)

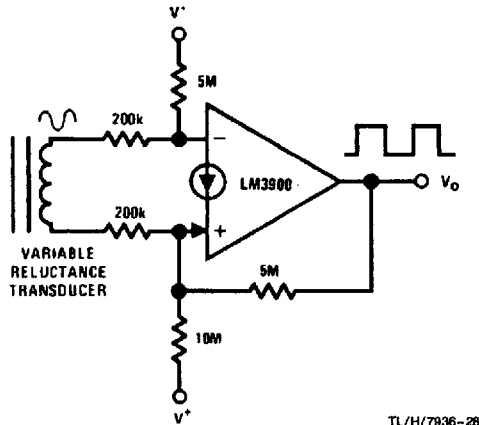

TL/H/7836-28

Bi-Stable Multivibrator

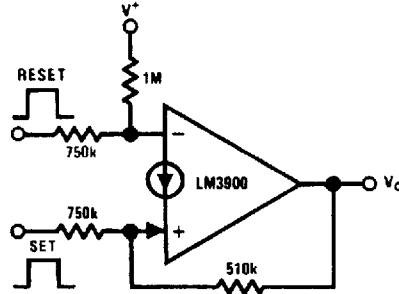

TL/H/7836-29

Differentiator (Common-Mode Biasing Keeps Input at +V_{BE})

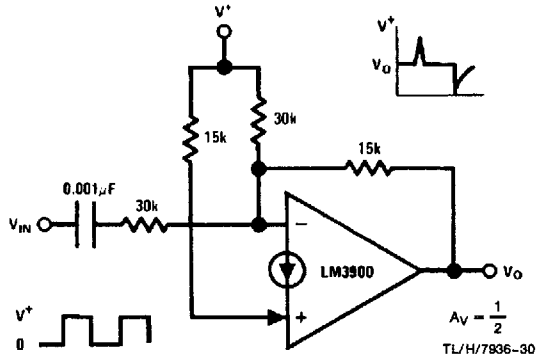

TL/H/7836-30

"OR" Gate

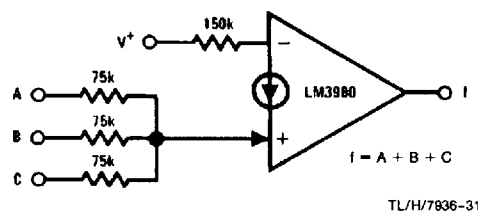

TL/H/7836-31

"AND" Gate

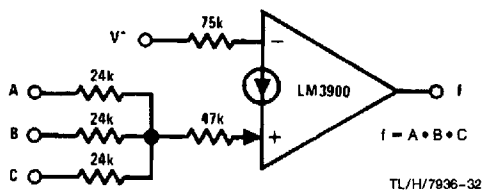

TL/H/7836-32

Difference Integrator

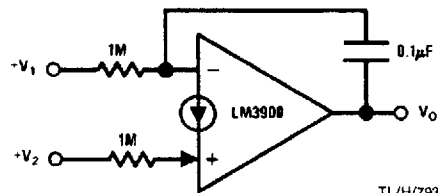

TL/H/7836-33

Typical Applications ($V^+ = 15 V_{DC}$) (Continued)

Low Pass Active Filter

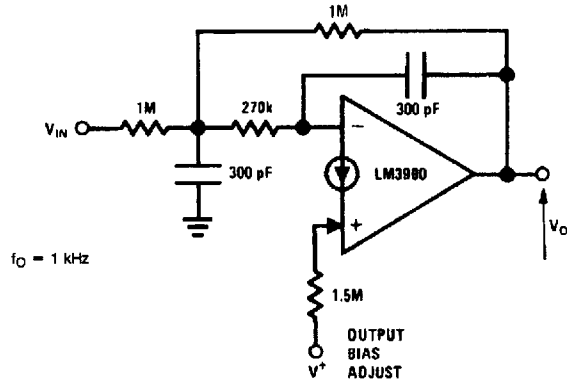

TL/H/7936-34

Staircase Generator

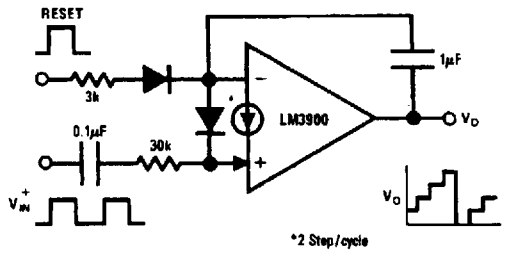

TL/H/7936-35

V_{BE} Biasing

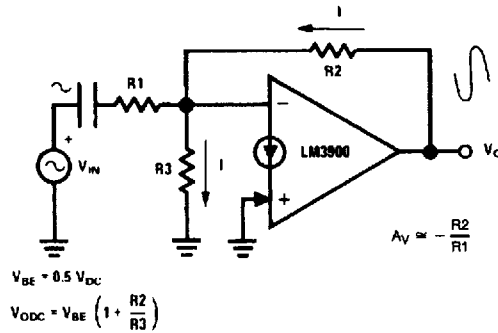

TL/H/7936-36

Bandpass Active Filter

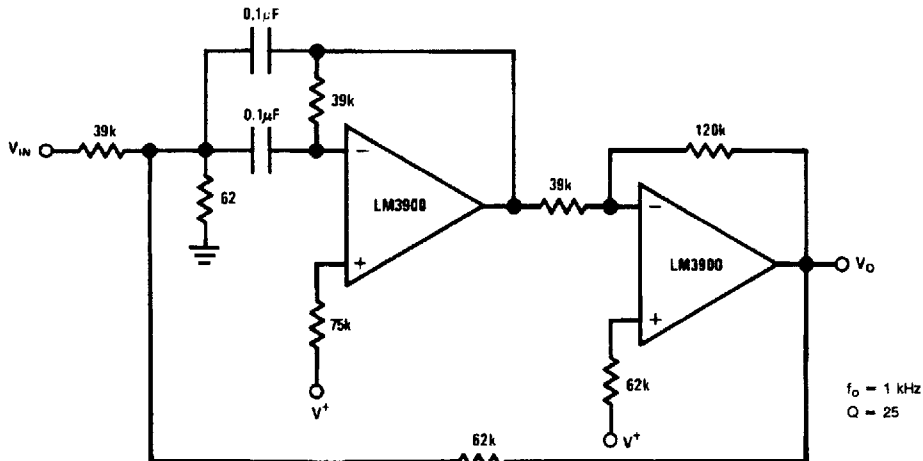

TL/H/7936-37

Typical Applications ($V^+ = 15 V_{DC}$) (Continued)

Low-Frequency Mixer

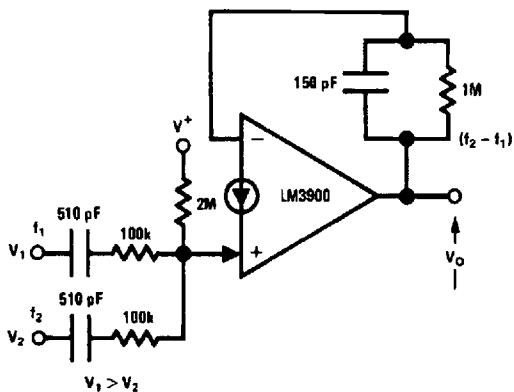

TL/H/7936-38

Free-Running Staircase Generator/Pulse Counter

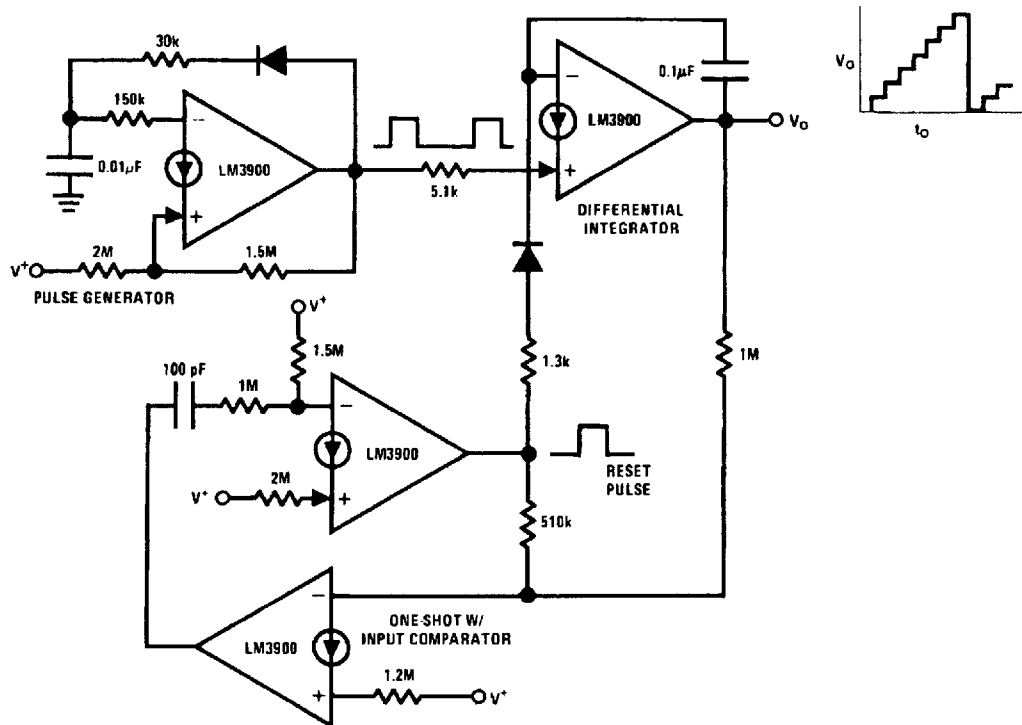

TL/H/7936-39

Typical Applications ($V^+ = 15\text{ V}_{DC}$) (Continued)

**Supplying I_{IN} with Aux. Amp
(to Allow Hi-Z Feedback Networks)**

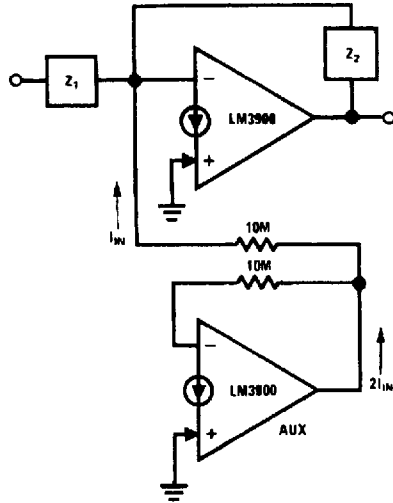

TL/H/7936-40

One-Shot Multivibrator

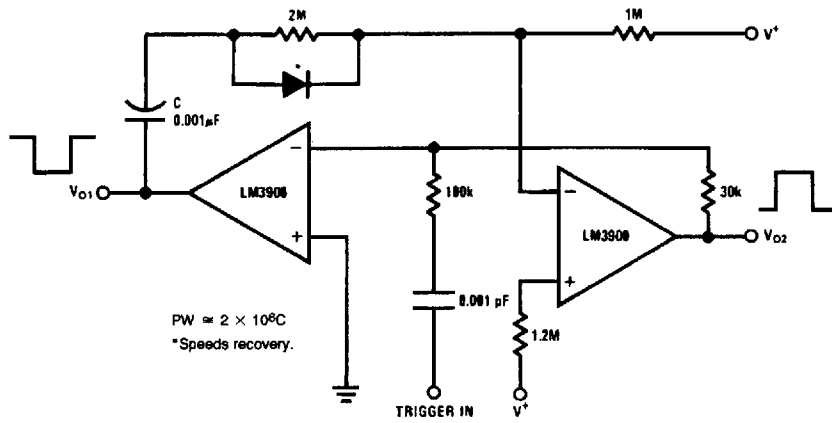

$PW \approx 2 \times 10^6 C$
*Speeds recovery.

TRIGGER IN

TL/H/7936-41

Non-Inverting DC Gain to (0,0)

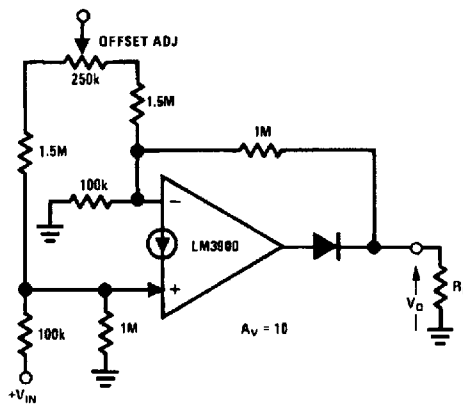

$A_v = 10$

TL/H/7936-42

Typical Applications ($V^+ = 15\text{ V}_{DC}$) (Continued)

Channel Selection by DC Control (or Audio Mixer)

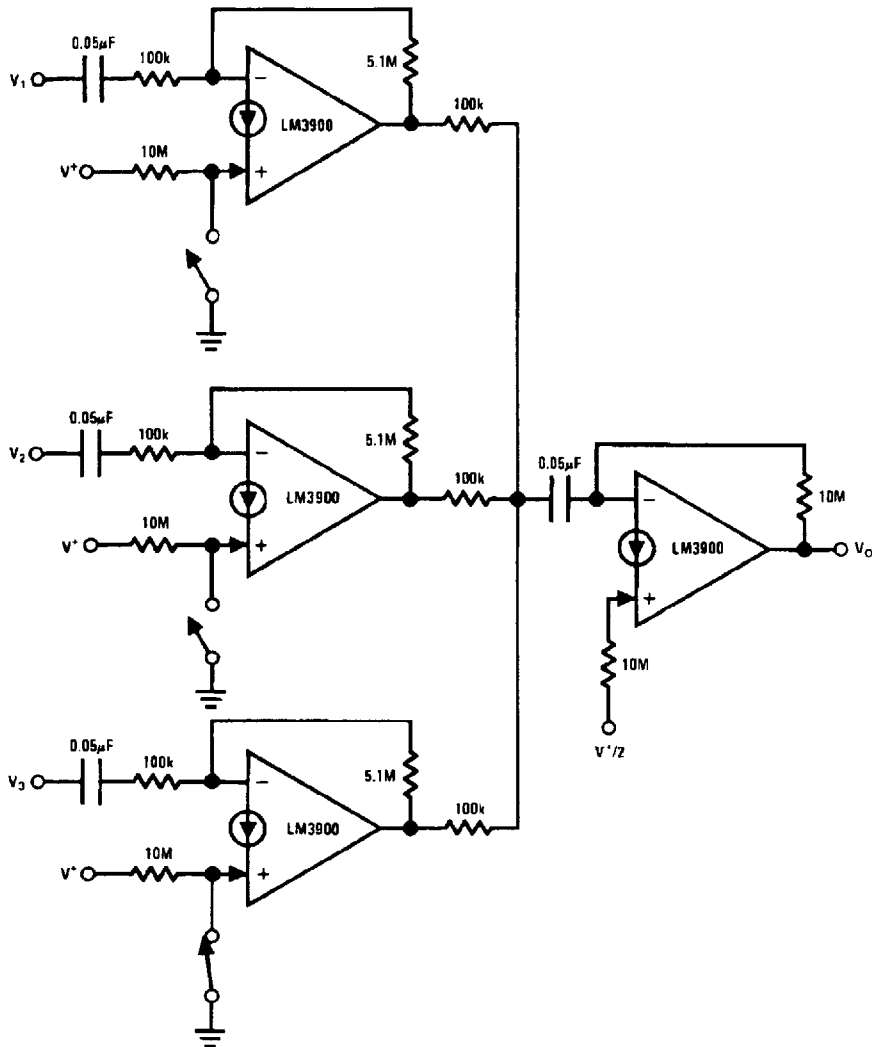

TL/H/7936-43

Typical Applications ($V^+ = 15 V_{DC}$) (Continued)

Power Amplifier

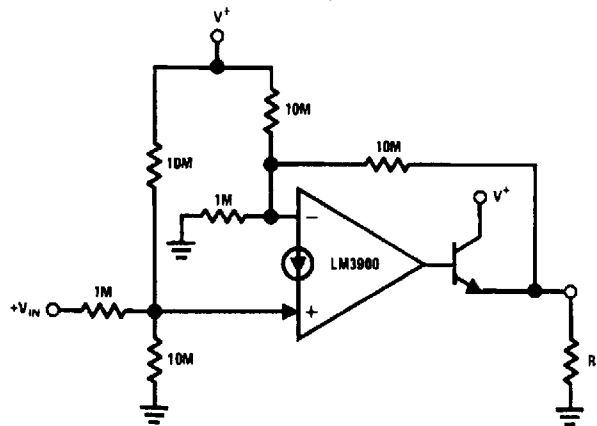

TL/H/7836-44

One-Shot with DC Input Comparator

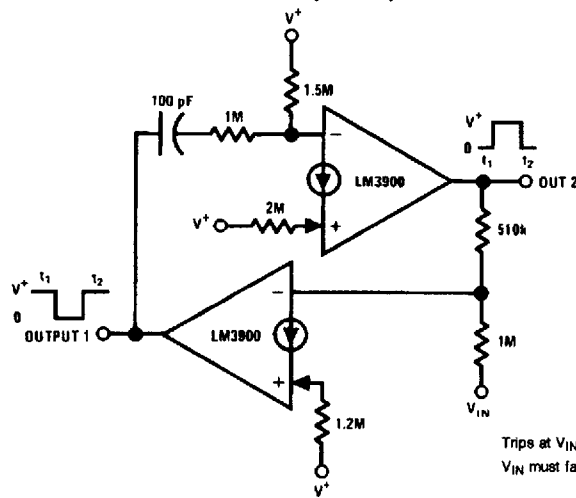

Trips at $V_{IN} \approx 0.8 V^+$
 V_{IN} must fall $0.8 V^+$ prior to t_2

TL/H/7836-45

High Pass Active Filter

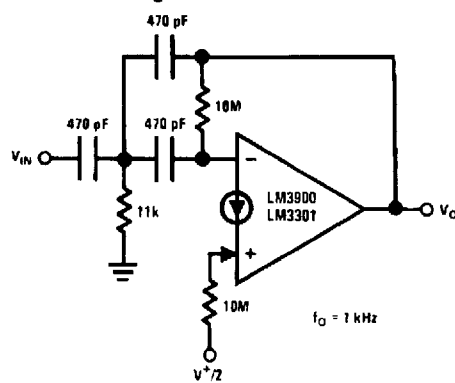

$f_0 = 1 \text{ kHz}$

TL/H/7836-46

Typical Applications ($V^+ = 15 V_{DC}$) (Continued)

Sample-Hold and Compare with New $+V_{IN}$

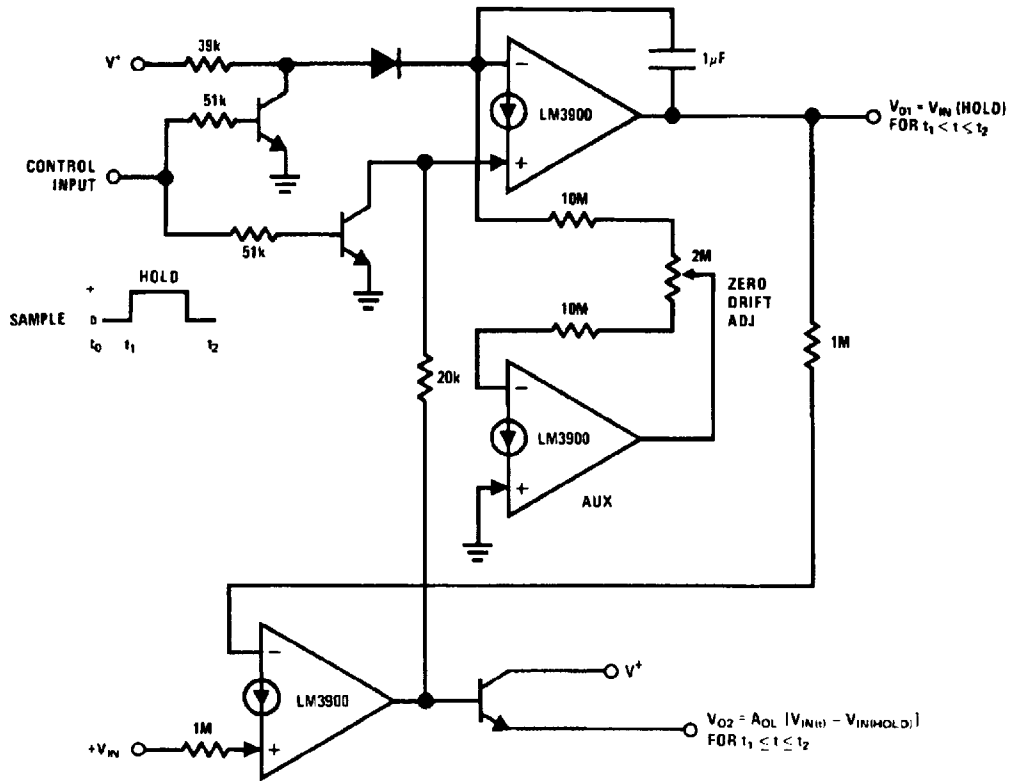

TL/H/7936-47

Sawtooth Generator

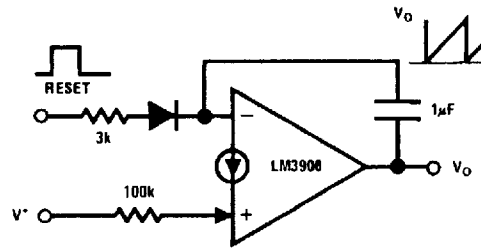

TL/H/7936-48

Typical Applications ($V^+ = 15\text{ V}_{\text{DC}}$) (Continued)

Phase-Locked Loop

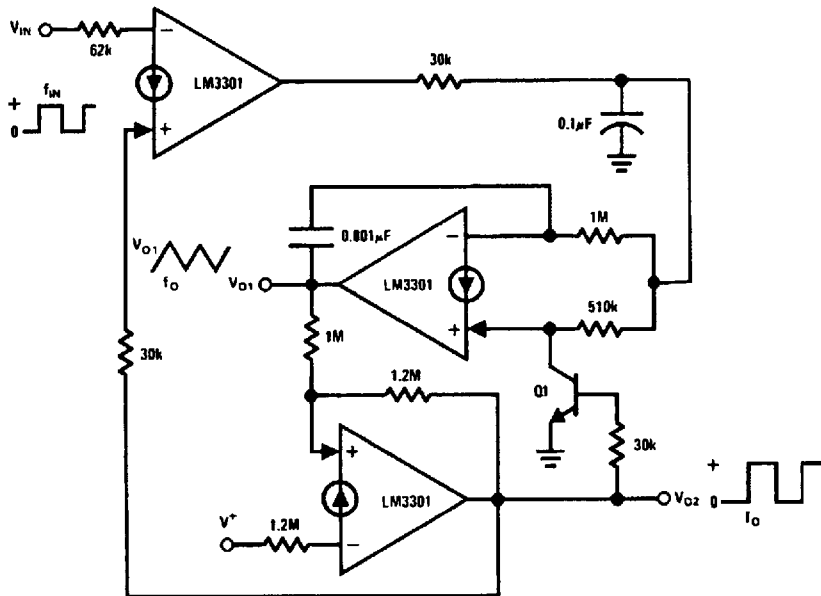

TL/H/7986-49

Boosting to 300 mA Loads

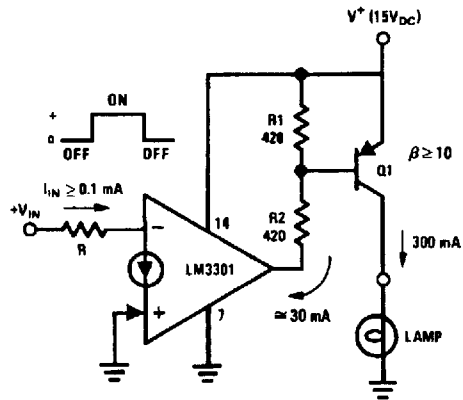

TL/H/7936-50

Split-Supply Applications ($V^+ = +15\text{ V}_{DC}$ & $V^- = -15\text{ V}_{DC}$)

Non-Inverting DC Gain

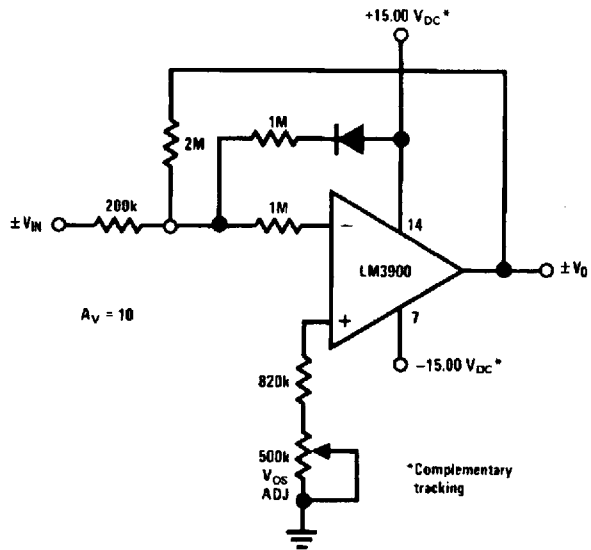

TL/H/7836-51

AC Amplifier

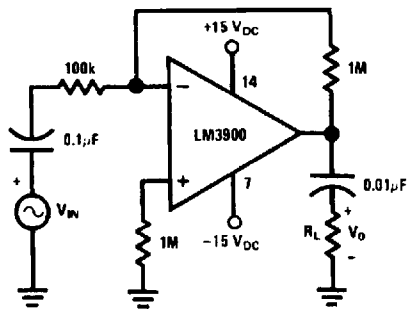

TL/H/7836-52

Physical Dimensions inches (millimeters)

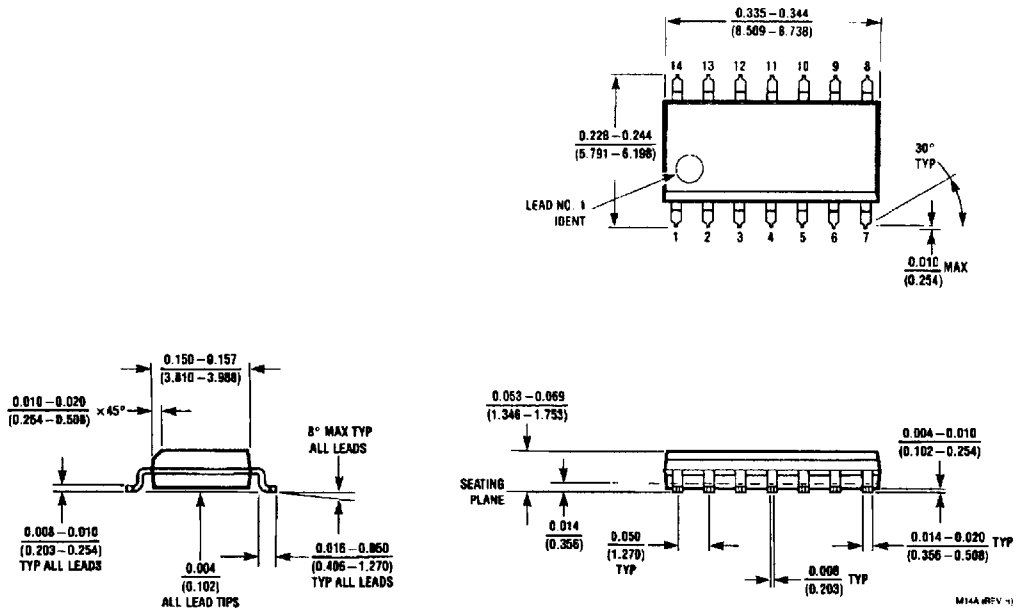

Small Outline Package (M)
Order Number LM3900M
NS Package Number M14A

M14A (REV. 1)

Physical Dimensions inches (millimeters) (Continued)

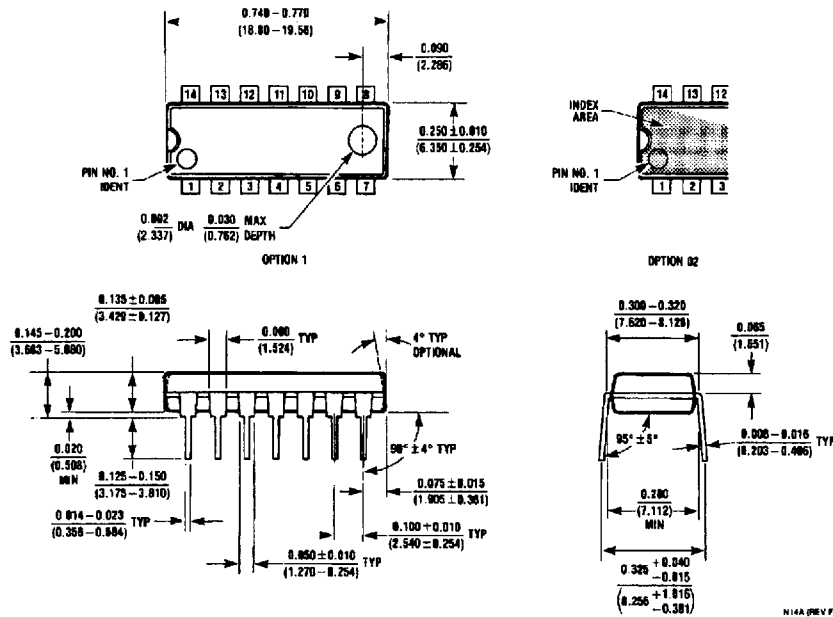

Molded Dual-In-Line Package (N)
Order Number LM2900N, LM3900N or LM3301N
NS Package Number N14A

LIFE SUPPORT POLICY

NATIONAL'S PRODUCTS ARE NOT AUTHORIZED FOR USE AS CRITICAL COMPONENTS IN LIFE SUPPORT DEVICES OR SYSTEMS WITHOUT THE EXPRESS WRITTEN APPROVAL OF THE PRESIDENT OF NATIONAL SEMICONDUCTOR CORPORATION. As used herein:

1. Life support devices or systems are devices or systems which, (a) are intended for surgical implant into the body, or (b) support or sustain life, and whose failure to perform, when properly used in accordance with instructions for use provided in the labeling, can be reasonably expected to result in a significant injury to the user.
2. A critical component is any component of a life support device or system whose failure to perform can be reasonably expected to cause the failure of the life support device or system, or to affect its safety or effectiveness.

National Semiconductor Corporation
 1111 West Bardin Road
 Arlington, TX 76017
 Tel: 1(800) 272-9959
 Fax: 1(800) 737-7018

National Semiconductor Europe
 Fax: (+49) 0-180-530 85 86
 Email: cnjwge@tevm2.nsc.com
 Deutsch Tel: (+49) 0-180-530 85 85
 English Tel: (+49) 0-180-532 78 32
 Français Tel: (+49) 0-180-532 83 58
 Italiano Tel: (+49) 0-180-534 16 80

National Semiconductor Hong Kong Ltd.
 13th Floor, Straight Block,
 Ocean Centre, 5 Canton Rd,
 Tsimshatsui, Kowloon
 Hong Kong
 Tel: (852) 2737-1600
 Fax: (852) 2736-9960

National Semiconductor Japan Ltd.
 Tel: 81-043-299-2309
 Fax: 81-043-299-2408

National does not assume any responsibility for use of any circuitry described, no circuit patent licenses are implied and National reserves the right at any time without notice to change said circuitry and specifications.