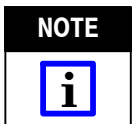

Figure 1

1. INTRODUCTION

Straight Action Crimpers 217200-[] are designed to be used with the tool holder assembly shown in Figure 1 and accept various crimping dies to adapt them for use with 626 pneumatic tooling assemblies. For information concerning the setup and operation of the pneumatic tool, refer to Customer Manual 409-5862.



Dimensions in this instruction sheet are in metric units [with U.S. customary units in brackets]. Figures and illustrations are for reference only and are not drawn to scale.

This instruction sheet provides:

- installation and removal of the straight action crimper from the tool holder assembly
- crimping die installation and removal from the straight action crimper
- maintenance, inspection, and repair information for the straight action crimper

Reasons for reissue of this instruction sheet are provided in Section 7, REVISION SUMMARY.

2. DESCRIPTION (Figure 1)

The straight action crimper facilitates the use of various crimping dies and connects to the tool holder assembly of the pneumatic tool to provide the necessary straight line motion of the crimping dies when the pneumatic tool is actuated. When actuated, a cam extends through the tool holder into the crimper, contacting an internal spring-loaded die holder mechanism. The other end of this mechanism is directly connected to the movable die and, as the cam pushes against the mechanism, the movable die moves in a straight line and bottoms against the stationary die. When the cam of the pneumatic tool retracts, the force is removed from the movable die and the spring-loaded mechanism returns to its starting position.

The crimping dies may also be opened and closed manually by using the plastic slide switch, which is coupled to the movable die and the spring-loaded mechanism via a screw. The slide switch therefore permits opening and closing of the crimping dies for insertion and removal of the terminal or splice.

3. INSTALLATION AND REMOVAL (Figure 1)

3.1. Straight Action Crimper

Before installing the straight action crimper, refer to 409-5862 for instructions on installing the tool holder

assembly (including the cam) on the pneumatic tool. After the tool holder assembly has been installed, proceed as follows:

DANGER  To prevent personal injury, ALWAYS disconnect the main air supply and electrical supply (if applicable) of the pneumatic tool before installing or removing the straight action crimper.

DANGER  DO NOT operate the pneumatic tool without the straight action crimper and the proper die assembly installed. After straight action crimper is installed, make sure that the quick pins are FULLY tightened to avoid personal injury and damage to the tool.

1. Remove the quick pins from the tool holder assembly.
2. Slide the crimper into the tool holder assembly, aligning the threaded holes of the crimper with the threaded quick pin holes of the tool holder assembly.
3. After the crimper is properly aligned in the tool holder assembly, insert and tighten the quick pins.

NOTE  Use Loctite 242 removable threadlocker, or equivalent, to prevent the quick pins from loosening.

NOTE  Removal is the reverse of installation.

3.2. Die Assembly

DANGER  To prevent personal injury, ALWAYS disconnect the main air supply and electrical supply (if applicable) of the pneumatic tool before installing or removing dies.

DANGER  DO NOT operate pneumatic tool without the straight action crimper and proper die assembly installed. After straight action crimper and crimping dies has been installed, make sure that the quick pins are FULLY tightened to avoid personal injury and damage to the tool.

1. Assemble the anvil (stationary) die to the indenter (movable) die as shown in Figure 2. The anvil is identifiable by the chamfers and the ejector.
2. Position tool holder assembly as shown in Figure 3, and install the die assembly.
3. Secure the die assembly in the die holder assembly with the die holding screws. See Figure 3.

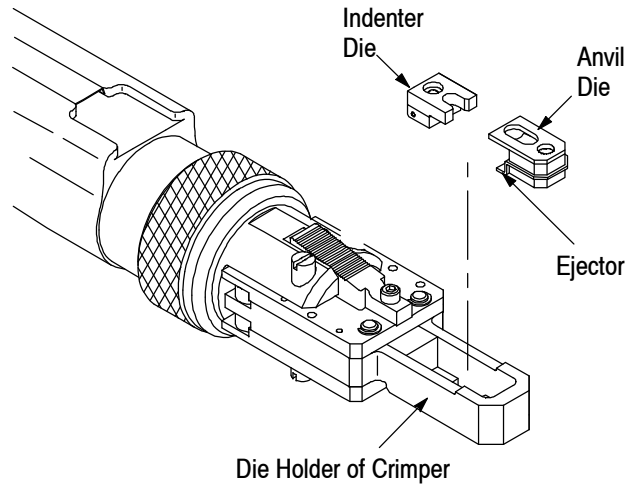

Figure 2

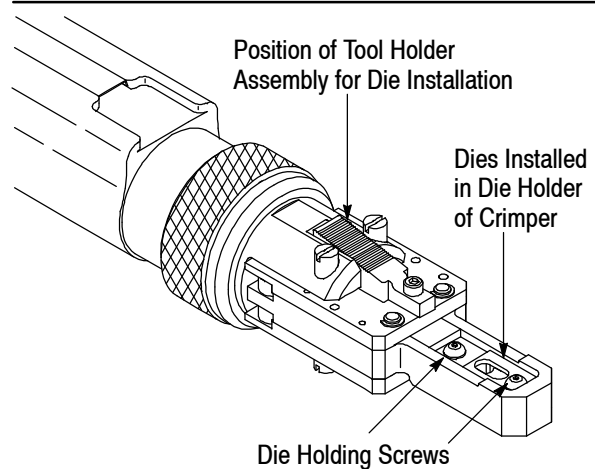



Figure 3

4. With the dies closed, tighten the die holding screws.
5. Connect the pneumatic tool to an adequate air supply (between 620 and 690 kPa [90 and 100 psi]). For specific information on air line requirements and air hose installation, refer to 409-5862.

NOTE  Removal is the reverse of installation.

Loctite is a trademark of Henkel Corporation.

4. MAINTENANCE AND INSPECTION

It is recommended that a maintenance and inspection program be performed periodically to ensure dependable and uniform terminations.



To avoid personal injury, ALWAYS disconnect the main air supply and electrical supply (if applicable) of the pneumatic tool system before performing maintenance or inspection.

4.1. Daily Maintenance

It is recommended that each operator be responsible for the following steps of daily maintenance:

1. Remove dust, moisture, and other contaminants with a clean, soft brush, or a lint-free cloth. DO NOT use objects that could damage the crimper.
2. Make sure that all pins, rings, and other components are in place and secure.
3. Make certain all surfaces are protected with a thin coat of any good SAE 20 motor oil. DO NOT oil excessively.
4. When the crimper is not in use, store it in a clean, dry area.

4.2. Periodic Inspection

Regular inspections should be performed by quality-control personnel. A record of scheduled inspections should remain with the crimper or be supplied to supervisory personnel responsible for the crimper. Though recommendations call for at least one inspection a month, the frequency should be based on amount of use, working conditions, operator training and skill, and your established company policies.

4.3. Visual Inspection

1. Remove all lubrication and accumulated film by immersing the crimper in a suitable commercial degreaser that will not affect paint or plastic.
2. Make certain all components are in place. If replacements are necessary, refer to Section 7, REPLACEMENT AND REPAIR.
3. Check all bearing surfaces for wear. Replace worn parts.

4.4. Lubrication

Lubricate all pins, pivot points, and bearing surfaces with a high-quality grease. Recommendations are for the use of Dow Corning Molykote paste, which is a commercially available lubricant. Lubricate according to the following schedule.

Crimper used in daily production — lubricate daily
 Crimper used daily (occasional) — lubricate weekly
 Crimper used weekly — lubricate monthly

5. OPTION FOR OPERATING CRIMPER WITH NORMALLY CLOSED DIES

Straight Action Crimper 217200-1 contains two internal springs (item 18, Figure 5) which spring-load the die holder of the crimper so that the dies are normally open. If it is desired to operate the crimper with the dies normally closed, the two springs (item 18) must be removed. To gain access to the internal die holder and springs, disassemble the crimper in accordance with the instructions in Section 6, CRIMPER DISASSEMBLY AND ASSEMBLY, then proceed as follows:

1. Lift the die holder assembly out from the center housing while being careful that the pins and rollers *do not* fall out of the links which are connected to the bottom of the die holder. Refer to Figure 4.
2. Insert the optional spring (item 13, Figure 5) between the links on the die holder assembly. First insert one end of the spring into the hole on the inside surface of one link then insert other end of spring into the hole on the inside surface of the other link.
3. While holding the ends of the two links together (compressing the spring), insert the die holder assembly back into the center housing. DO NOT re-install the two springs (item 18, Figure 5).
4. Re-assemble the crimper in accordance with the instructions in Section 6.

6. CRIMPER DISASSEMBLY AND ASSEMBLY

These instructions provide disassembly and assembly procedures which are to be used whenever internal parts of the crimper are to be replaced or removed.

6.1. Disassembly (Refer to Figure 4)

1. Obtain a 12.7-mm [.50-in.] thick wooden block with a surface area large enough to accommodate the crimper. Lay the flat side of the crimper (side opposite the plastic switch) on the work surface of the block and mark the block at the approximate locations of the two slotted spring pins that are inserted through the sides of the crimper. Using the marks, drill two $\frac{1}{4}$ -in. holes through the wooden block. The holes will facilitate driving the slotted spring pins out the bottom of the crimper.
2. Re-position the crimper on the block so that the slotted pins line up with the holes in the block. Using a $\frac{1}{8}$ -in. punch, drive the slotted pins approximately 6.35 mm [.250 in.] through the crimper housing.

SAE is a trademark of SAE International Corporation.

Dow Corning and Molykote are registered trademarks of Dow Corning Corporation.

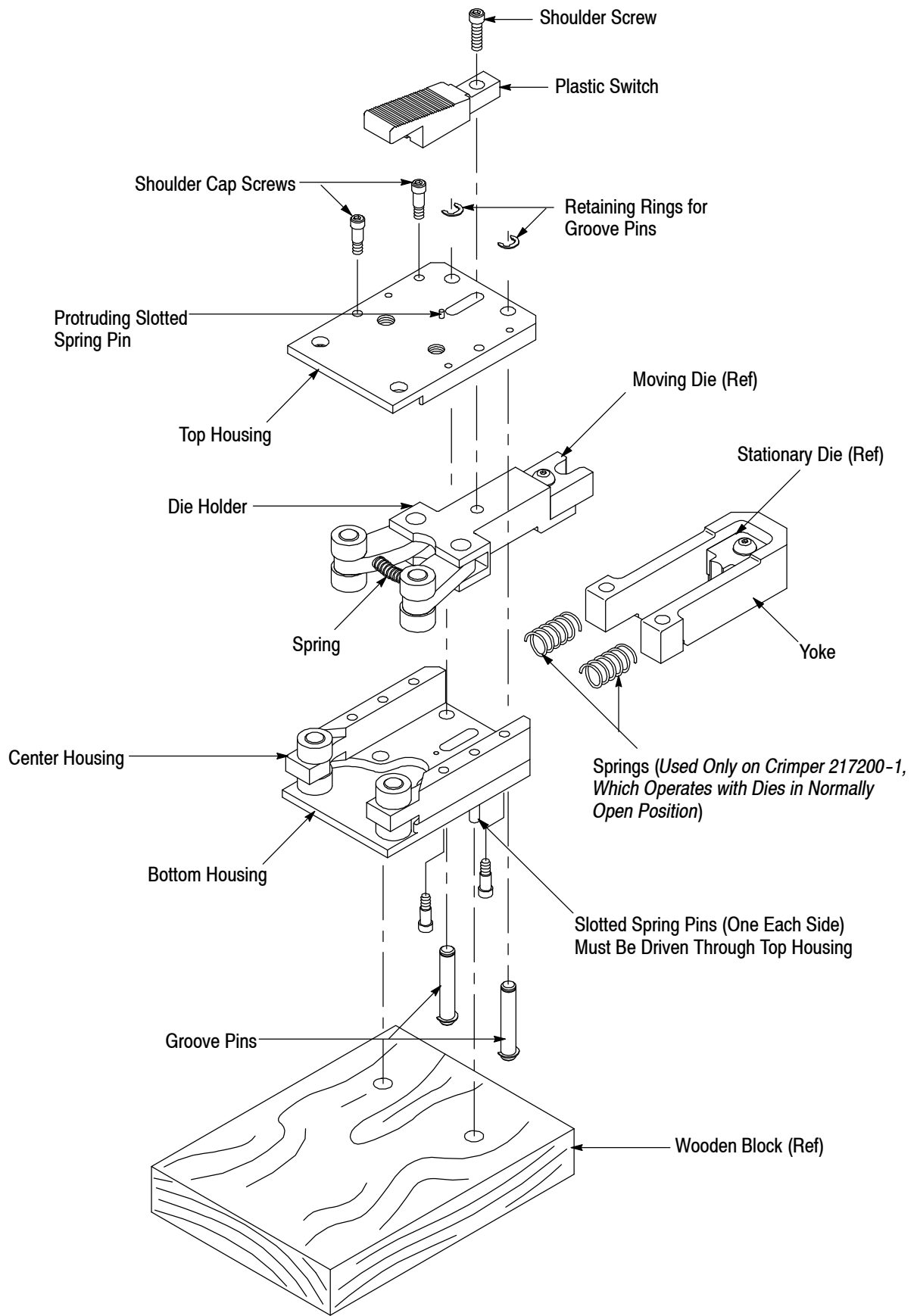

Figure 4

3. Remove two retaining rings securing the two groove pins at the top of the crimper housing (on either side of the plastic switch), then remove the groove pins.

NOTE

The groove pins secure the yoke, and it may be necessary to hold the yoke in place while removing the groove pins. When the groove pins are removed, the yoke will be pushed out of the housing by the two internal springs (if not previously removed).

4. Remove the shoulder screw which secures the plastic switch to the internal die holder and remove the plastic switch.

5. Remove the four shoulder cap screws which secure the two outer housings to the center housing, then remove the outer housing.

6.2. Assembly (Refer to Figure 4)

1. Properly position the die holder assembly in the center housing.

NOTE

If the optional spring (item 13, Figure 5) is to be installed, refer to Section 5, OPTION FOR OPERATING CRIMPER WITH NORMALLY CLOSED DIES, to install spring. Then proceed to Step 2 to complete assembly.

2. Re-install the outer housing and secure with the four shoulder cap screws. DO NOT tighten the screws.

3. Install the two springs (item 18, Figure 5) in the top end cavities of the housing.

4. Install the yoke into top of housing and, after aligning the groove pin holes in the yoke with the holes in the housing, install the groove pins and secure with retaining rings.

NOTE

It may be necessary to hold the yoke in place while installing the groove pins. If groove pins cannot be fully inserted through the housing, loosen the four shoulder cap screws (installed in Step 2) to provide more freedom of movement of the outer housing.

5. Position the plastic switch so that the protruding slotted spring pin fits into the groove on the bottom side of the switch. Then slide the switch to align its mounting hole with the hole in the die holder.

6. Insert the shoulder screw through the plastic switch into the hole in the die holder and tighten the screw.

7. Tighten the four shoulder cap screws.

8. Using a bench vice, press the two slotted spring pins back into the housing.

7. REPLACEMENT AND REPAIR

Customer-replaceable parts are provided in Figure 5. A complete inventory should be stocked and controlled to prevent lost time when replacement of parts is necessary. Order replacement parts through your Representative, or call 1-800-526-5142, or send a facsimile of your purchase order to 717-986-7605 or write to:

CUSTOMER SERVICE (038-035)
TYCO ELECTRONICS CORPORATION
PO BOX 3608
HARRISBURG PA 17105-3608

For customer repair service, call 1-800-526-5136.

8. REVISION SUMMARY

Revisions to this instruction sheet include:

- Added "Original Instructions" to page 1
- Removed Proper Use Guidelines (tools are not manually operated)
- Corrected Step 3 of Paragraph 6.2 (changed item 19 to 18)

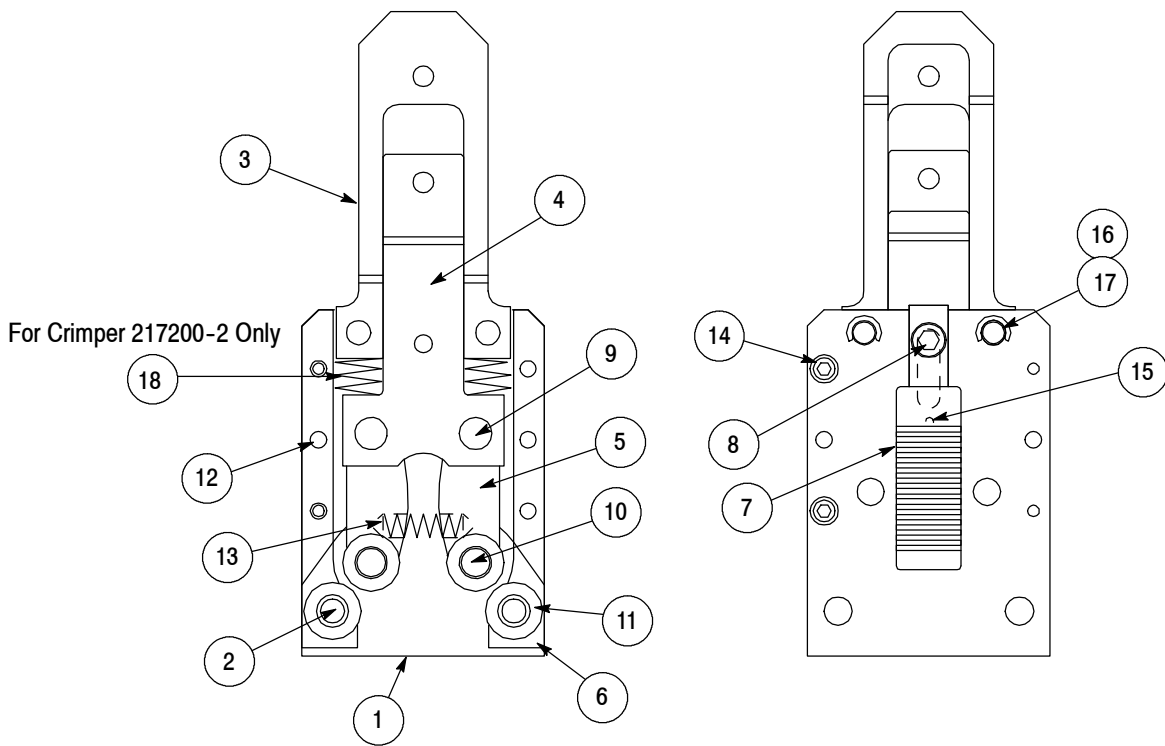

REPLACEMENT PARTS

ITEM	PART NUMBER	DESCRIPTION	QTY PER CRIMPER
1	217349-1	HOUSING	2
2	217347-1■	PIN, Fixed	2
3	217345-1	YOKE	1
4	217344-1	HOLDER, Die	1
5	217343-1	LINK	2
6	217342-1	HOUSING, Center	2
7	217340-1	SWITCH, Plastic	1
8	1-21989-1	SCREW, Shoulder	1
9	679495-1	PIN	2
10	217348-1■	PIN	2
11	314479-4■	ROLLER	8
12	4-21028-4	PIN, Slotted Spring	2
13	3-22279-8■	SPRING	1
14	6-21000-8	SCREW, Socket Head Cap, 4-40 UNC × .875-in.	4
15	21028-1	PIN, Slotted Spring	1
16	5-23619-3	PIN, Groove	2
17	21045-3	RING, Retaining	4
18	22282-4‡■	SPRING (Used Only For Normally Open Dies)	2

■ Recommended Spare Part

‡ For Crimper 217200-2 Only

Figure 5