

## Low-power single operational amplifier

Datasheet - production data

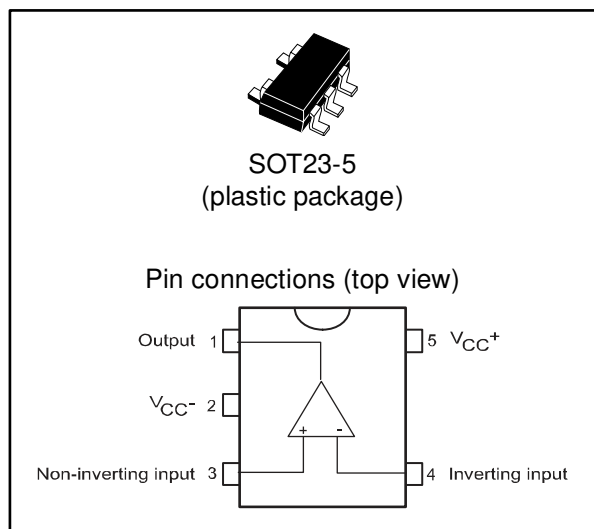

## Description

The TS321 device is intended for cost-sensitive applications where space-saving is of great importance. This bipolar operational amplifier (op amp) offers the benefits of a reduced component size (SOT23-5 package) with specifications that match (or are better than) industry standard devices (such as the popular LM358A, LM324, and other similar devices). The TS321 device has an input common mode range ( $V_{icm}$ ) that includes ground and therefore can be employed in single supply applications.

## Features

- Large output voltage swing
  - 0 to 3.5 V min ( $V_{CC} = 5$  V)
- Low supply current: 500  $\mu$ A
- Low input bias current: 20 nA
- Low input offset voltage
  - 2 mV max. for TS321A
  - 4 mV max. for TS321
- Wide power supply range
  - Single supply: 3 to 30 V
  - Dual supplies:  $\pm 1.5$  to  $\pm 15$  V
- Stable with high capacitive loads

# Contents

- 1 Schematic diagram..... 3**
- 2 Absolute maximum ratings and operating conditions ..... 4**
- 3 Electrical characteristics ..... 5**
- 4 Macromodel ..... 8**
  - 4.1 Important note concerning this macromodel ..... 8
  - 4.2 Macromodel code..... 8
  - 4.3 Electrical characteristics of the macromodel ..... 10
- 5 Package information ..... 11**
  - 5.1 SOT23-5 package information ..... 12
- 6 Ordering information..... 13**
- 7 Revision history ..... 14**

# 1 Schematic diagram

Figure 1: Schematic diagram

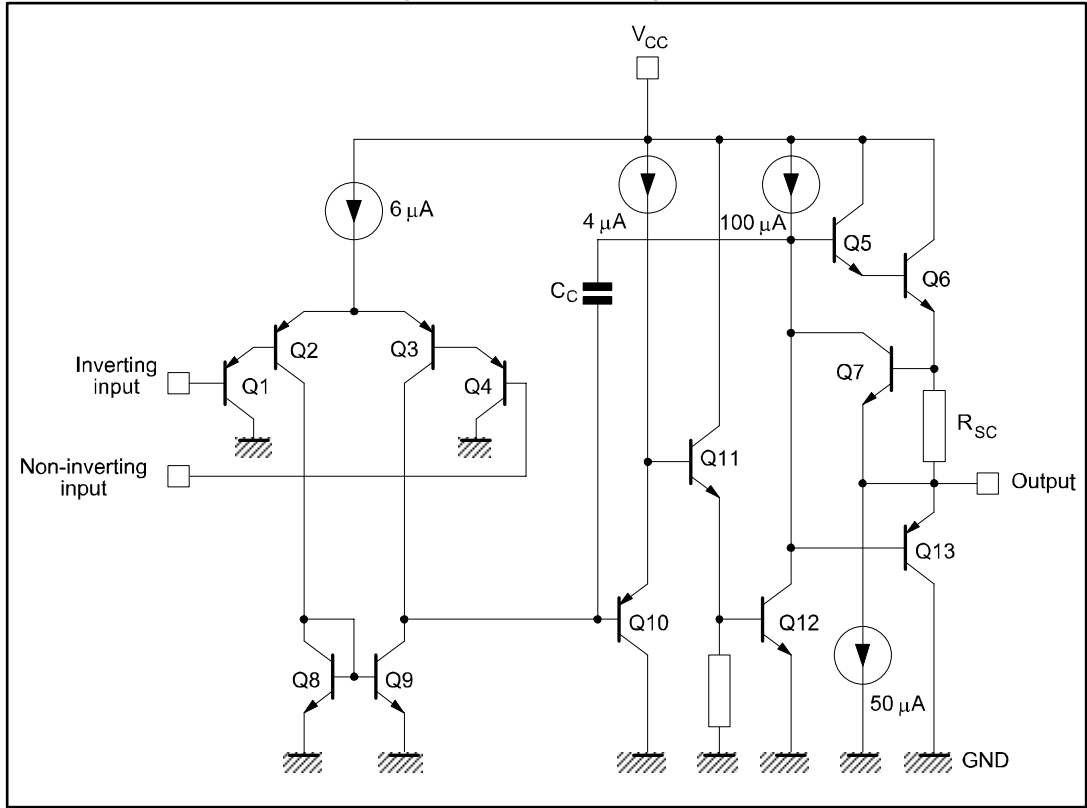

## 2 Absolute maximum ratings and operating conditions

Table 1: Absolute maximum ratings

Symbol	Parameter	Value	Unit
$V_{CC}^+$	Supply voltage	$\pm 16$ to 32	V
$V_{in}$	Input voltage	-0.3 to 32	
$V_{id}$	Differential input voltage	$\pm 32$	
	Output short-circuit duration <sup>(1)</sup>	Infinite	
$I_{in}$	Input current <sup>(2)</sup>	50	mA
$T_{stg}$	Storage temperature range	-65 to 150	°C
$T_j$	Maximum junction temperature	150	
$R_{thja}$	Thermal resistance junction-to-ambient <sup>(3)</sup>	250	°C/W
$R_{thjc}$	Thermal resistance junction-to-case <sup>(3)</sup>	81	
ESD	HBM: human body model <sup>(4)</sup>	500	V
	MM: machine model <sup>(5)</sup>	200	
	CDM: charged device model <sup>(6)</sup>	1000	

**Notes:**

<sup>(1)</sup>Short-circuits from the output to  $V_{CC}$  can cause excessive heating if  $V_{CC} > 15$  V. The maximum output current is approximately 40 mA independent of the magnitude of  $V_{CC}$ .

<sup>(2)</sup>This input current only exists when the voltage at any of the input leads is driven negative. It is due to the collector-base junction of the input PNP transistor becoming forward biased and thereby acting as input diodes clamps. In addition to this diode action, there is also NPN parasitic action on the IC chip. This transistor action can cause the output voltages of the op amp to go to the  $V_{CC}$  voltage level (or to ground for a large overdrive) for the time during which an input is driven negative. This is not destructive and normal output is restored when the input voltage goes back above -0.3 V.

<sup>(3)</sup>Short-circuits can cause excessive heating. Destructive dissipation can result from simultaneous short-circuits on all amplifiers. All values are typical.

<sup>(4)</sup>Human body model: a 100 pF capacitor is charged to the specified voltage, then discharged through a 1.5 kΩ resistor between two pins of the device. This is done for all couples of connected pin combinations while the other pins are floating.

<sup>(5)</sup>Machine model: a 200 pF capacitor is charged to the specified voltage, then discharged directly between two pins of the device with no external series resistor (internal resistor < 5 Ω). This is done for all couples of connected pin combinations while the other pins are floating.

<sup>(6)</sup>Charged device model: all pins and the package are charged together to the specified voltage and then discharged directly to ground through only one pin. This is done for all pins.

Table 2: Operating conditions

Symbol	Parameter	Value	Unit	
$V_{CC}^+$	Supply voltage	3 to 30	V	
$V_{icm}$	Input common mode voltage range ( $V_{CC}^+ = 30$ V)	$T_{amb} = 25$ °C		0 to ( $V_{CC}^+$ ) - 1.5
		$T_{min} \leq T_{amb} \leq T_{max}$		0 to ( $V_{CC}^+$ ) - 2
$T_{oper}$	Operating free air temperature range	-40 to 125	°C	



### 3 Electrical characteristics

Table 3: Electrical characteristics at  $V_{CC}^+ = 5\text{ V}$ ,  $V_{CC}^- = \text{ground}$ ,  $V_o = 1.4\text{ V}$ ,  $T_{\text{amb}} = 25\text{ }^\circ\text{C}$   
(unless otherwise specified)

Symbol	Parameter	Test conditions	Min.	Typ.	Max.	Unit
$V_{io}$	Input offset voltage <sup>(1)</sup>	TS321		0.5	4	mV
		TS321A			2	
		$T_{\text{min}} \leq T_{\text{amb}} \leq T_{\text{max}}$ , TS321			5	
		$T_{\text{min}} \leq T_{\text{amb}} \leq T_{\text{max}}$ , TS321A			3	
$I_{io}$	Input offset current			2	30	nA
		$T_{\text{min}} \leq T_{\text{amb}} \leq T_{\text{max}}$			50	
$I_{ib}$	Input bias current <sup>(2)</sup>			20	150	nA
		$T_{\text{min}} \leq T_{\text{amb}} \leq T_{\text{max}}$			200	
$A_{vd}$	Large signal voltage gain	$V_{CC}^+ = 15\text{ V}$ , $R_L = 2\text{ k}\Omega$ , $V_o = 1.4\text{ to }11.4\text{ V}$	50	100		V/mV
		$T_{\text{min}} \leq T_{\text{amb}} \leq T_{\text{max}}$ , $V_{CC}^+ = 15\text{ V}$ , $R_L = 2\text{ k}\Omega$ , $V_o = 1.4\text{ to }11.4\text{ V}$	25			
SVR	Supply voltage rejection ratio	$R_s \leq 10\text{ k}\Omega$ , $V_{CC}^+ = 5\text{ to }30\text{ V}$	65	110		dB
$I_{CC}$	Supply current, no load	$V_{CC}^+ = 5\text{ V}$		500	800	$\mu\text{A}$
		$V_{CC}^+ = 30\text{ V}$		600	900	
		$T_{\text{min}} \leq T_{\text{amb}} \leq T_{\text{max}}$ , $V_{CC}^+ = 5\text{ V}$		600	900	
		$T_{\text{min}} \leq T_{\text{amb}} \leq T_{\text{max}}$ , $V_{CC}^+ = 30\text{ V}$			1000	
CMR	Common mode rejection ratio	$R_s \leq 10\text{ k}\Omega$	65	85		dB
$I_{\text{source}}$	Output current source	$V_{id} = 1\text{ V}$ , $V_{CC}^+ = 15\text{ V}$ , $V_o = 2\text{ V}$	20	40		mA
$I_{\text{sink}}$	Output sink current	$V_{id} = -1\text{ V}$ , $V_{CC}^+ = 15\text{ V}$ , $V_o = 2\text{ V}$	10	20		mA
		$V_{id} = -1\text{ V}$ , $V_{CC}^+ = 15\text{ V}$ , $V_o = 0.2\text{ V}$	12	50		$\mu\text{A}$
$I_o$	Short-circuit to ground	$V_{CC}^+ = 15$		40	60	mA
$V_{OH}$	High-level output voltage	$V_{CC}^+ = 30\text{ V}$ , $R_L = 2\text{ k}\Omega$	26	27		V
		$T_{\text{min}} \leq T_{\text{amb}} \leq T_{\text{max}}$ , $V_{CC}^+ = 30\text{ V}$ , $R_L = 2\text{ k}\Omega$	25.5			
		$V_{CC}^+ = 30\text{ V}$ , $R_L = 10\text{ k}\Omega$	27	28		
		$T_{\text{min}} \leq T_{\text{amb}} \leq T_{\text{max}}$ , $V_{CC}^+ = 30\text{ V}$ , $R_L = 10\text{ k}\Omega$	26.5			
		$V_{CC}^+ = 5\text{ V}$ , $R_L = 2\text{ k}\Omega$	3.5			
		$T_{\text{min}} \leq T_{\text{amb}} \leq T_{\text{max}}$ , $V_{CC}^+ = 5\text{ V}$ , $R_L = 2\text{ k}\Omega$	3			
$V_{OL}$	Low level output voltage	$R_L = 10\text{ k}\Omega$		5	15	mV
		$T_{\text{min}} \leq T_{\text{amb}} \leq T_{\text{max}}$ , $R_L = 10\text{ k}\Omega$			20	
SR	Slew rate	$V_{CC}^+ = 15\text{ V}$ , $V_i = 0.5\text{ to }3\text{ V}$ , $R_L = 2\text{ k}\Omega$ , $C_L = 100\text{ pF}$ , unity gain		0.4		V/ $\mu\text{s}$

Symbol	Parameter	Test conditions	Min.	Typ.	Max.	Unit
GBP	Gain bandwidth product	$V_{CC}^+ = 30\text{ V}$ , $f = 100\text{ kHz}$ , $V_{in} = 10\text{ mV}$ , $R_L = 2\text{ k}\Omega$ , $C_L = 100\text{ pF}$		0.8		MHz
$\phi_m$	Phase margin			60		Degrees
THD	Total harmonic distortion	$f = 1\text{ kHz}$ , $A_v = 20\text{ dB}$ , $R_L = 2\text{ k}\Omega$ , $V_o = 2\text{ V}_{pp}$ , $C_L = 100\text{ pF}$ , $V_{CC}^+ = 30\text{ V}$		0.015		%
$e_n$	Equivalent input noise voltage	$f = 1\text{ kHz}$ , $R_s = 100\ \Omega$ , $V_{CC}^+ = 30\text{ V}$		40		$\frac{\text{nV}}{\sqrt{\text{Hz}}}$

**Notes:**

(1)  $V_o = 1.4\text{ V}$ ,  $R_s = 0\ \Omega$ ,  $5\text{ V} < (V_{CC}^+) < 30\text{ V}$ ,  $0 < V_{icm} < (V_{CC}^+) - 1.5\text{ V}$

(2) The direction of the input current is out of the IC. This current is essentially constant and independent of the state of the output. Therefore, there is no change in the load on the input lines.

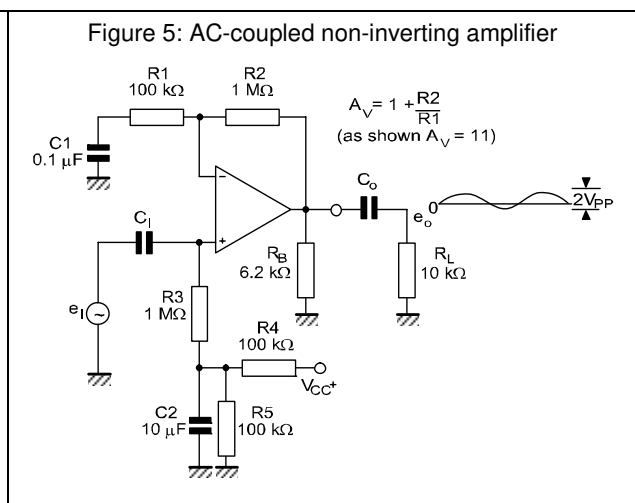
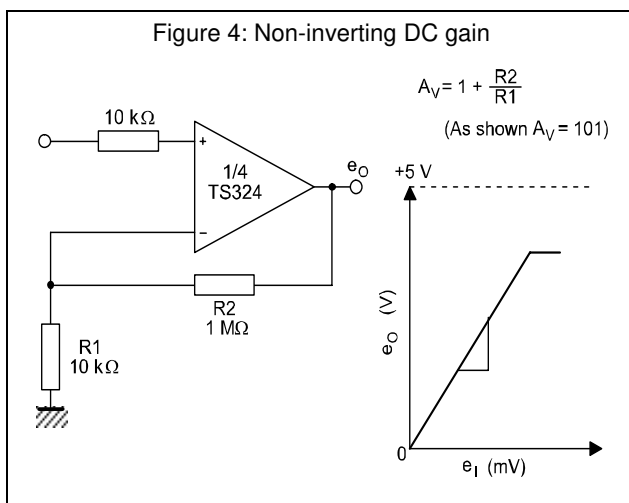
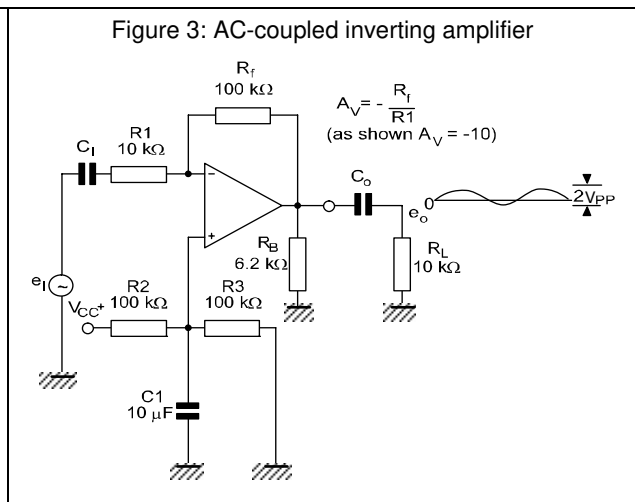
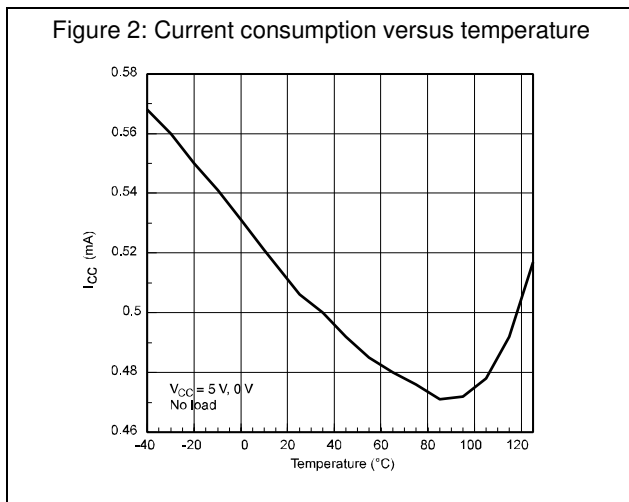
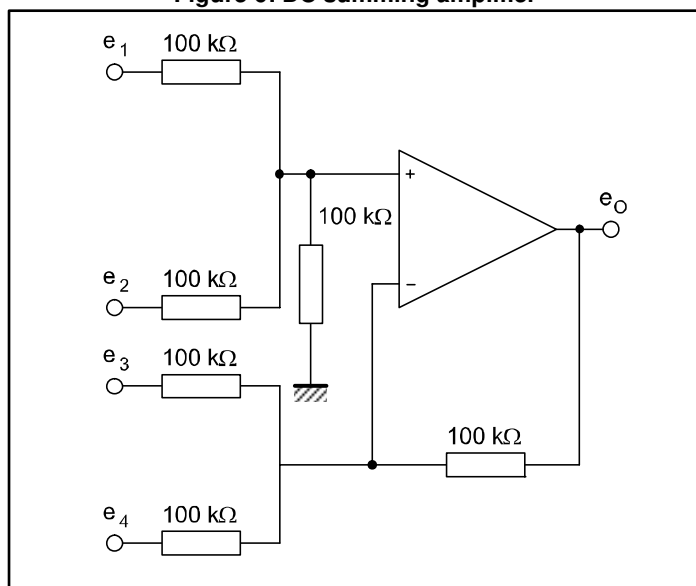

Figure 6: DC summing amplifier



## 4 Macromodel

### 4.1 Important note concerning this macromodel

Please note the following points before using this macromodel

- All models are a trade-off between accuracy and complexity (that is, simulation time)
- Macromodels are not a substitute for breadboarding, rather, they confirm the validity of a design approach and help to select surrounding component values.
- A macromodel emulates the nominal performance of a typical device within specified operating conditions (for example, temperature and supply voltage). Thus, the macromodel is often not as exhaustive as the datasheet. Its purpose is to illustrate the main parameters of the product.

Data derived from macromodels used outside the specified conditions (for example,  $V_{CC}$  and temperature) or even worse, outside of the device's operating conditions (for example,  $V_{CC}$  and  $V_{icm}$ ), are not reliable in any way.

### 4.2 Macromodel code

```
** Standard Linear Ics Macromodels, 1993.
** CONNECTIONS :
* 1 INVERTING INPUT
* 2 NON-INVERTING INPUT
* 3 OUTPUT
* 4 POSITIVE POWER SUPPLY
* 5 NEGATIVE POWER SUPPLY
.SUBCKT TS321 1 2 3 4 5
*****
.MODEL MDTH D IS=1E-8 KF=3.104131E-15 CJO=10F
* INPUT STAGE
CIP 2 5 1.000000E-12
CIN 1 5 1.000000E-12
EIP 10 5 2 5 1
EIN 16 5 1 5 1
RIP 10 11 2.600000E+01
RIN 15 16 2.600000E+01
RIS 11 15 2.003862E+02
DIP 11 12 MDTH 400E-12
DIN 15 14 MDTH 400E-12
VOFP 12 13 DC 0
VOFN 13 14 DC 0
IPOL 13 5 1.000000E-05
CPS 11 15 3.783376E-09
DINN 17 13 MDTH 400E-12
```



```
VIN 17 5 0.000000e+00
DINR 15 18 MDTH 400E-12
VIP 4 18 2.000000E+00
FCP 4 5 VOFP 3.400000E+01
FCN 5 4 VOFN 3.400000E+01
FIBP 2 5 VOFN 2.000000E-03
FIBN 5 1 VOFP 2.000000E-03
* AMPLIFYING STAGE
FIP 5 19 VOFP 3.600000E+02
FIN 5 19 VOFN 3.600000E+02
RG1 19 5 3.652997E+06
RG2 19 4 3.652997E+06
CC 19 5 6.000000E-09
DOPM 19 22 MDTH 400E-12
DONM 21 19 MDTH 400E-12
HOPM 22 28 VOUT 7.500000E+03
VIPM 28 4 1.500000E+02
HONM 21 27 VOUT 7.500000E+03
VINM 5 27 1.500000E+02
EOUT 26 23 19 5 1
VOUT 23 5 0
ROUT 26 3 20
COUT 3 5 1.000000E-12
DOP 19 25 MDTH 400E-12
VOP 4 25 2.242230E+00
DON 24 19 MDTH 400E-12
VON 24 5 7.922301E-01
.ENDS
```

### 4.3 Electrical characteristics of the macromodel

**Table 4: Electrical characteristics at  $V_{CC^+} = 3\text{ V}$ ,  $V_{CC^-} = 0\text{ V}$ ,  $R_L$  and  $C_L$  connected to  $V_{CC}/2$ ,  $T_{amb} = 25\text{ °C}$  (unless otherwise specified)**

Symbol	Conditions	Value	Unit
$V_{io}$		0	mV
$A_{vd}$	$R_L = 2\text{ k}\Omega$	100	V/mV
$I_{CC}$	No load, per operator	300	$\mu\text{A}$
$V_{icm}$		0 to 3.5	V
$V_{OH}$	$R_L = 2\text{ k}\Omega$	3.5	V
$V_{OL}$		5	mV
$I_{os}$	$V_o = 0\text{ V}$	40	mA
GBP	$R_L = 2\text{ k}\Omega$ , $C_L = 100\text{ pF}$	0.8	MHz
SR		0.4	V/ $\mu\text{s}$
$\phi_m$		60	Degrees

## 5 Package information

In order to meet environmental requirements, ST offers these devices in different grades of ECOPACK<sup>®</sup> packages, depending on their level of environmental compliance. ECOPACK<sup>®</sup> specifications, grade definitions and product status are available at: [www.st.com](http://www.st.com). ECOPACK<sup>®</sup> is an ST trademark.

### 5.1 SOT23-5 package information

Figure 7: SOT23-5 package mechanical drawing

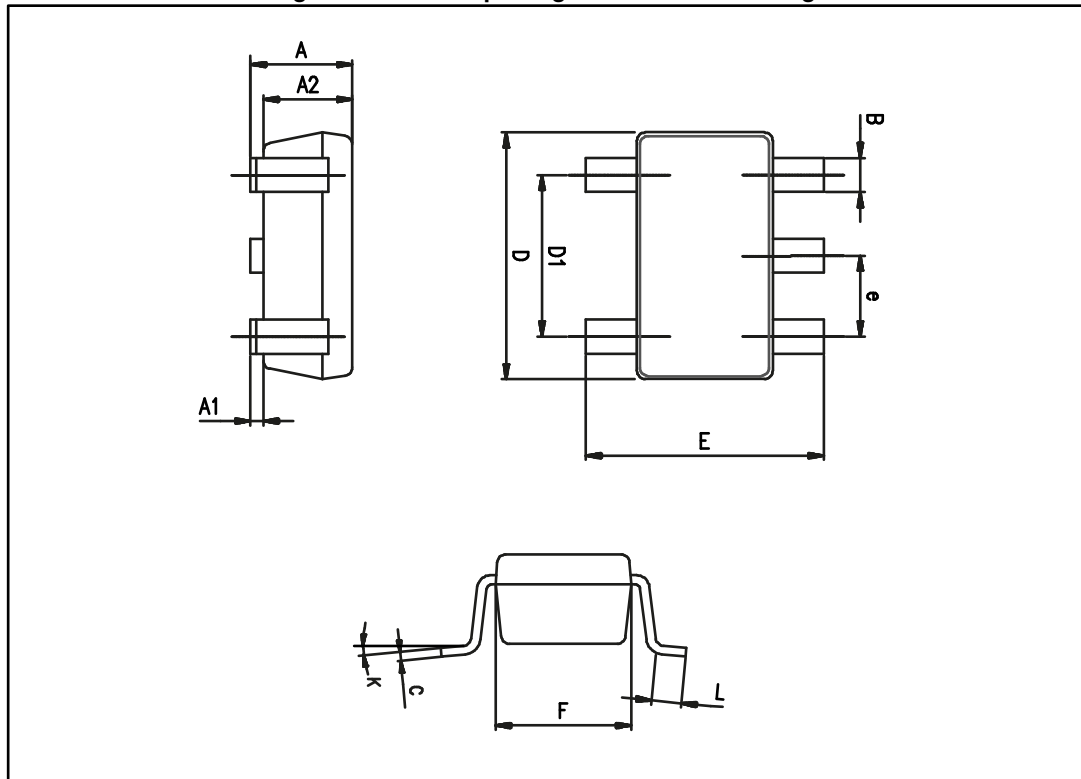

Table 5: SOT23-5 package mechanical data

Ref.	Dimensions					
	Millimeters			Inches		
	Min.	Typ.	Max.	Min.	Typ.	Max.
A	0.90	1.20	1.45	0.035	0.047	0.057
A1			0.15			0.006
A2	0.90	1.05	1.30	0.035	0.041	0.051
B	0.35	0.40	0.50	0.014	0.016	0.020
C	0.09	0.15	0.20	0.004	0.006	0.008
D	2.80	2.90	3.00	0.110	0.114	0.118
D1		1.90			0.075	
e		0.95			0.037	
E	2.60	2.80	3.00	0.102	0.110	0.118
F	1.50	1.60	1.75	0.059	0.063	0.069
L	0.10	0.35	0.60	0.004	0.014	0.024
K	0 degrees		10 degrees	0 degrees		10 degrees

## 6 Ordering information

Table 6: Order codes

Order code	Temperature range	Package	Packaging	Marking
TS321ILT	-40 °C to 125 °C	SOT23-5	Tape and reel	K401
TS321AILT				K402
TS321IYLT <sup>(1)</sup>				K406
TS321AIYLT <sup>(1)</sup>				K407

**Notes:**

<sup>(1)</sup> Qualified and characterized according to AEC Q100 and Q003 or equivalent, advanced screening according to AEC Q001 and Q 002 or equivalent.

## 7 Revision history

**Table 7: Document revision history**

Date	Revision	Changes
30-Jun-2001	1	Initial release
04-Jul-2005	2	PPAP references inserted in the datasheet, see order codes table. ESD protection inserted in <a href="#">Table 1: Absolute maximum ratings</a> .
06-Sep-2005	3	Correction of errors in package names and markings in order codes table. Minor grammatical and formatting corrections.
12-Dec-2005	4	Missing PPAP references inserted, see order codes table. Thermal resistance junction to ambient and thermal resistance junction to case information added in <a href="#">Table 1: Absolute maximum ratings</a> . Macromodel updated see <a href="#">Section 4: Macromodel</a> .
08-Nov-2007	5	Added CDM value for SO-8 in <a href="#">Table 1: Absolute maximum ratings</a> . Added Tj value in <a href="#">Table 1: Absolute maximum ratings</a> . Macromodel updated see <a href="#">Section 4: Macromodel</a> . Reformatted package information. Added footnote in <a href="#">Table 7: Order codes</a> . Removed TS321IYD/IYDT and TS321AIYD/AIYDT order codes.
08-Jul-2008	6	Added CDM value for SOT23-5 package in <a href="#">Table 1: Absolute maximum ratings</a> .
10-May-2010	7	Updated package information in <a href="#">Chapter 5</a> .
12-Sep-2010	8	Qualified status of TS321IYLT and TS321AIYLT order codes in <a href="#">Table 7: Order codes</a> , minor corrections throughout document.
12-Nov-2014	9	Removed SO8 package and all references to it <a href="#">Table 1: Absolute maximum ratings</a> : Updated ESD, HBM data <a href="#">Section 5.1</a> : updated SOT23-5 package information <a href="#">Table 7: Order codes</a> : removed obsolete order codes (TS321ID, TS321IDT, TS321AID, TS321AIDT)

**IMPORTANT NOTICE – PLEASE READ CAREFULLY**

STMicroelectronics NV and its subsidiaries ("ST") reserve the right to make changes, corrections, enhancements, modifications, and improvements to ST products and/or to this document at any time without notice. Purchasers should obtain the latest relevant information on ST products before placing orders. ST products are sold pursuant to ST's terms and conditions of sale in place at the time of order acknowledgement.

Purchasers are solely responsible for the choice, selection, and use of ST products and ST assumes no liability for application assistance or the design of Purchasers' products.

No license, express or implied, to any intellectual property right is granted by ST herein.

Resale of ST products with provisions different from the information set forth herein shall void any warranty granted by ST for such product.

ST and the ST logo are trademarks of ST. All other product or service names are the property of their respective owners.

Information in this document supersedes and replaces information previously supplied in any prior versions of this document.

© 2014 STMicroelectronics – All rights reserved