

CAB-S-S-25G-1M-C

Arista Networks® CAB-S-S-25G-1M Compatible TAA Compliant 25GBase-CU SFP28 Direct Attach Cable (Passive Twinax, 1m)

Features

- Up to 25Gb/s bi-directional data links
- Compliant with SFF-8402
- Operating case temperature: 0°C to 70°C
- Single 3.3V supply voltage
- AC coupled inputs and outputs
- Hot pluggable
- 100 Ohm differential impedance
- Enhanced EMI design
- Wire Gauge: 30AWG
- Compliant with IEEE 802.3by
- Compliant with RoHS



Application

- 25GBASE Ethernet

Product Description

This is an Arista Networks® CAB-S-S-25G-1M compatible 25GBase-CU SFP28 to SFP28 direct attach cable that operates over passive copper with a maximum reach of 1.0m (3.3ft). It has been programmed, uniquely serialized, and data-traffic and application tested to ensure it is 100% compliant and functional. This direct attach cable is TAA (Trade Agreements Act) compliant, and is built to comply with MSA (Multi-Source Agreement) standards. We stand behind the quality of our products and proudly offer a limited lifetime warranty.

ProLabs' direct attach cables are RoHS compliant and lead-free.

TAA refers to the Trade Agreements Act (19 U.S.C. & 2501-2581), which is intended to foster fair and open international trade. TAA requires that the U.S. Government may acquire only "U.S. – made or designated country end products."



Recommended Operating Conditions

Parameter	Symbol	Min.	Typ.	Max.	Unit	Notes
Operating Case Temperature	Tc	0		70	degC	
Storage Temperature	Ts	-40		85	degC	
Relative Humidity (non-condensing)	RH	5		85	%	
Input Voltage	Vcc	3.14	3.3	3.46	V	1
Power Supply Current	ICC			4	mA	1
Data Rate	DR		25		Gb/s	2
Bit Error Rate	BER			10 ⁻¹²		

Notes:

1. For electrical power interface
2. IEEE 802.3by

Pin Descriptions

Pin	Logic	Symbol	Name/Descriptions	Ref.
1		VeeT	Module Transmitter Ground	1
2	LVTTTL-O	Tx_Fault	Transmitter Fault	2
3	LVTTTL-I	Tx_Disable	Transmitter Disable	3
4	LVTTTL-I/O	SDA	MOD-DEF2 2-wire serial interface data line	4
5	LVTTTL-I/O	SCL	MOD-DEF1 2-wire serial interface clock line	4
6		Mod_Abs	Module Absent	5
7	LVTTTL-I	RS0	Rate Select Zero	
8	LVTTTL-O	Rx_LOS	Module Receiver Loss of Signal	2
9	LVTTTL-I	RS1	Rate Select One	
10		VeeR	Module Receiver Ground	1
11		VeeR	Module Receiver Ground	1
12	CML-O	RD-	Receiver Inverted Data Output	
13	CML-O	RD+	Receiver Non-Inverted Data Output	
14		VeeR	Module Receiver Ground	1
15		VccR	Module Receiver 3.3V Supply	
16		VccT	Module Transmitter 3.3V Supply	
17		VeeT	Module Transmitter Ground	1
18	CML-I	TD+	Transmitter Non-Inverted Data Input	
19	CML-I	TD-	Transmitter Inverted Data Input	
20		VeeT	Module Transmitter Ground	1

Notes:

1. The module signal grounds, VeeR and VeeT, shall be isolated from the module case.
2. This is an open collector/drain output and shall be pulled up with 4.7-10k to Vcc_Host on the host board. Pull ups can be connected to multiple power supplies, however the host board design shall ensure that no module has voltage exceeding module VccT/R + 0.5 V.
3. This is an open collector/drain input and shall be pulled up with 4.7-10k to VccT in the module.
4. See 2-wire electrical specification.
5. This shall be pulled up with 4.7-10k to Vcc_Host on the host board.

Host Board Connector Pinout for SFP28

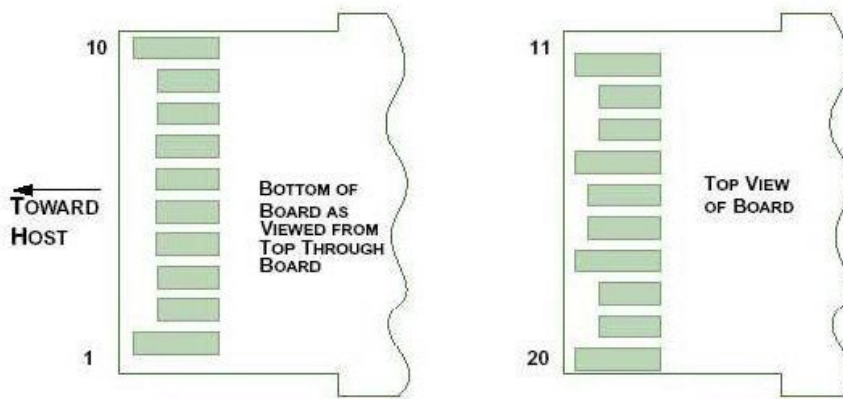

Mechanical Specifications

Parameter	Symbol	Minimum	Typical	Maximum	Unit
Wire Gauge		30AWG			AWG
Cable Impedance	Z	90	100	110	Ohm
Cable Diameter OD (30 AWG)			4.6		mm
Minimum Bending Radius R (30 AWG)		26			mm
Insertion Loss Level			CA-25G-N		
30AWG Product Weight	G _{D30}		78		g/PCS
30AWG Cable Weight	G _{C30}		32		g/M
Dust Cap Weight	G _s		0.80		g/PCS

Mechanical Dimensions

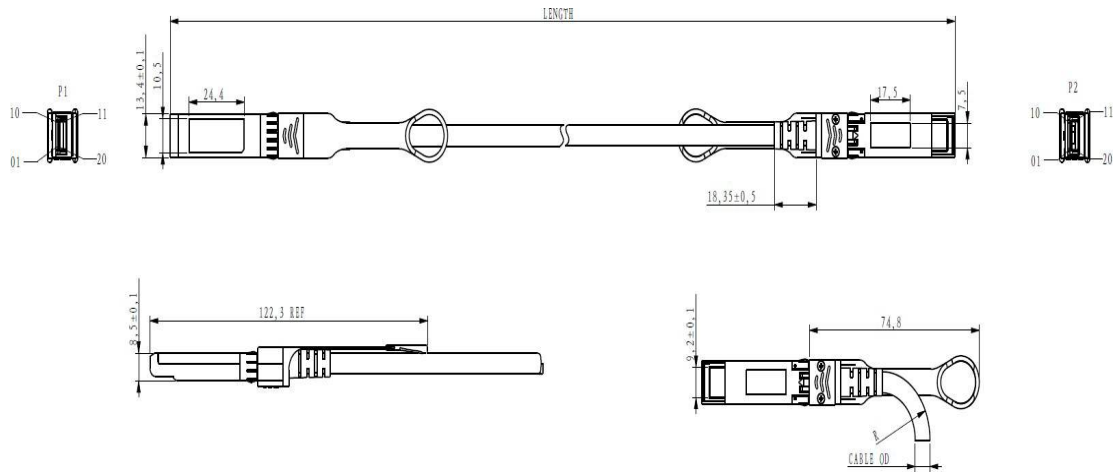

Length Tolerance

Nominal Length (m)	Tolerance Range ±(cm)
Length≤3	2
3<Length≤4	4
4<Length≤5	6

About ProLabs

Our experience comes as standard; for over 15 years ProLabs has delivered optical connectivity solutions that give our customers freedom and choice through our ability to provide seamless interoperability. At the heart of our company is the ability to provide state-of-the-art optical transport and connectivity solutions that are compatible with over 90 optical switching and transport platforms.

Complete Portfolio of Network Solutions

ProLabs is focused on innovations in optical transport and connectivity. The combination of our knowledge of optics and networking equipment enables ProLabs to be your single source for optical transport and connectivity solutions from 100Mb to 400G while providing innovative solutions that increase network efficiency. We provide the optical connectivity expertise that is compatible with and enhances your switching and transport equipment.

Trusted Partner

Customer service is our number one value. ProLabs has invested in people, labs and manufacturing capacity to ensure that you get immediate answers to your questions and compatible product when needed. With Engineering and Manufacturing offices in the U.K. and U.S. augmented by field offices throughout the U.S., U.K. and Asia, ProLabs is able to be our customers best advocate 24 hours a day.

Contact Information

ProLabs US

Email: sales@prolabs.com

Telephone: 952-852-0252

ProLabs UK

Email: salessupport@prolabs.com

Telephone: +44 1285 719 600