



SANYO Semiconductors

DATA SHEET

An ON Semiconductor Company

LV5215LF — Bi-CMOS LSI 4ch LED Driver

Overview

The LV5215LF is an LED driver IC for use in cell phones.

Features

- Four main LED driver circuits
- Supports two LED current modes
- Miniature package
- Thermal shutdown function

Specifications

Maximum Ratings at Ta = 25°C

Parameter	Symbol	Conditions	Ratings	Unit
Maximum supply voltage	V _{CC} max	V _{CC}	6	V
Maximum input voltage 1	V ₁ max	MLED1, MLED2, MLED3, MLED4	6	V
Maximum output current	I _O max	I _{LED}	25	mA
Allowable power dissipation	P _d max	Mounted on a circuit board.*	0.41	W
Operating temperature	T _{opr}		-30 to +75	°C
Storage temperature	T _{stg}		-40 to +125	°C

* Specified circuit board : 40×50×0.8mm³ : glass epoxy four-layer

Recommended Operating Conditions at Ta = 25°C

Parameter	Symbol	Conditions	Ratings	Unit
Supply voltage 1	VBAT		3.0 to 4.5	V

■ Any and all SANYO Semiconductor Co.,Ltd. products described or contained herein are, with regard to "standard application", intended for the use as general electronics equipment (home appliances, AV equipment, communication device, office equipment, industrial equipment etc.). The products mentioned herein shall not be intended for use for any "special application" (medical equipment whose purpose is to sustain life, aerospace instrument, nuclear control device, burning appliances, transportation machine, traffic signal system, safety equipment etc.) that shall require extremely high level of reliability and can directly threaten human lives in case of failure or malfunction of the product or may cause harm to human bodies, nor shall they grant any guarantee thereof. If you should intend to use our products for applications outside the standard applications of our customer who is considering such use and/or outside the scope of our intended standard applications, please consult with us prior to the intended use. If there is no consultation or inquiry before the intended use, our customer shall be solely responsible for the use.

■ Specifications of any and all SANYO Semiconductor Co.,Ltd. products described or contained herein stipulate the performance, characteristics, and functions of the described products in the independent state, and are not guarantees of the performance, characteristics, and functions of the described products as mounted in the customer's products or equipment. To verify symptoms and states that cannot be evaluated in an independent device, the customer should always evaluate and test devices mounted in the customer's products or equipment.

LV5215LF

Electrical Characteristics at Unless otherwise specified Ta = 25°C, VBAT = 3.7V

Parameter	Symbol	Conditions	Ratings			Unit
			min	typ	max	
[Analog Block] Current drain						
Current drain 1	I _{CC1}	VBAT + VDD current drain. CTL: low		0	5	μA
Current drain 2	I _{CC2}	CTL : H		3	5	mA
LED Driver Block at R1 = 110kΩ, R2 = 11kΩ						
LED current 1	I _{LED1}	V _O = 0.5V *1	1	2	3	mA
LED current 2	I _{LED2}	V _O = 0.5V *1	18	20	22	mA
Control Circuit Block						
High level 1	V _{INH1}	High-level input *2	1.5		VBAT	V
Low level 1	V _{INL1}	Low-level input *2	0		0.3	V
Switch on state resistance	RON	SWI pin : VBAT		200		Ω

*1 : ILED will have a value about 200 times that of the current (IRT) flowing in the current setting resistor (RT).

*2 : The IC operates when CTL is high, and stops when CTL is low.

Package Dimensions

unit : mm (typ)

3335

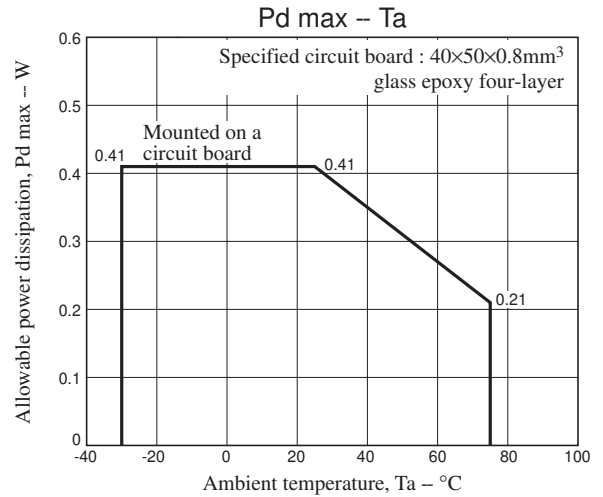
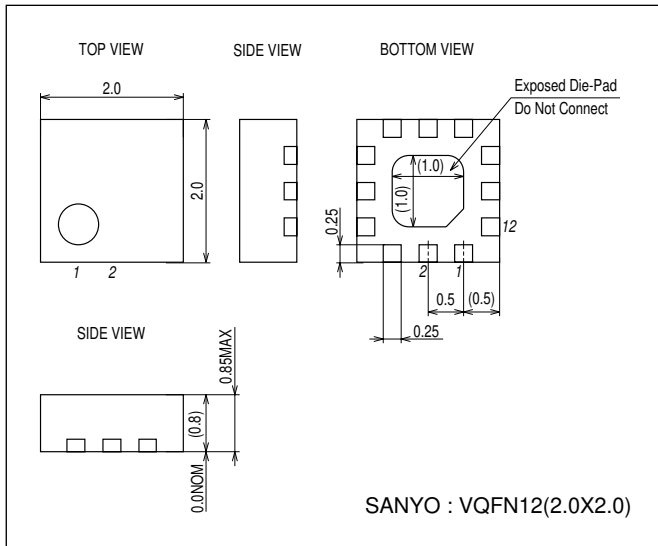

Pin Assignment

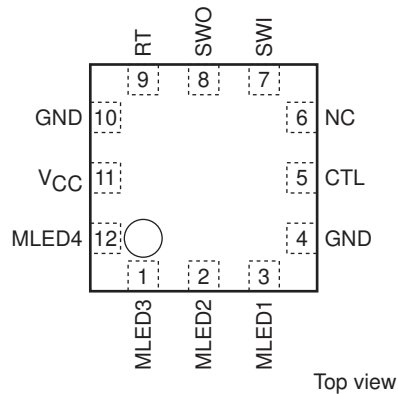

LV5215LF

Block Diagram

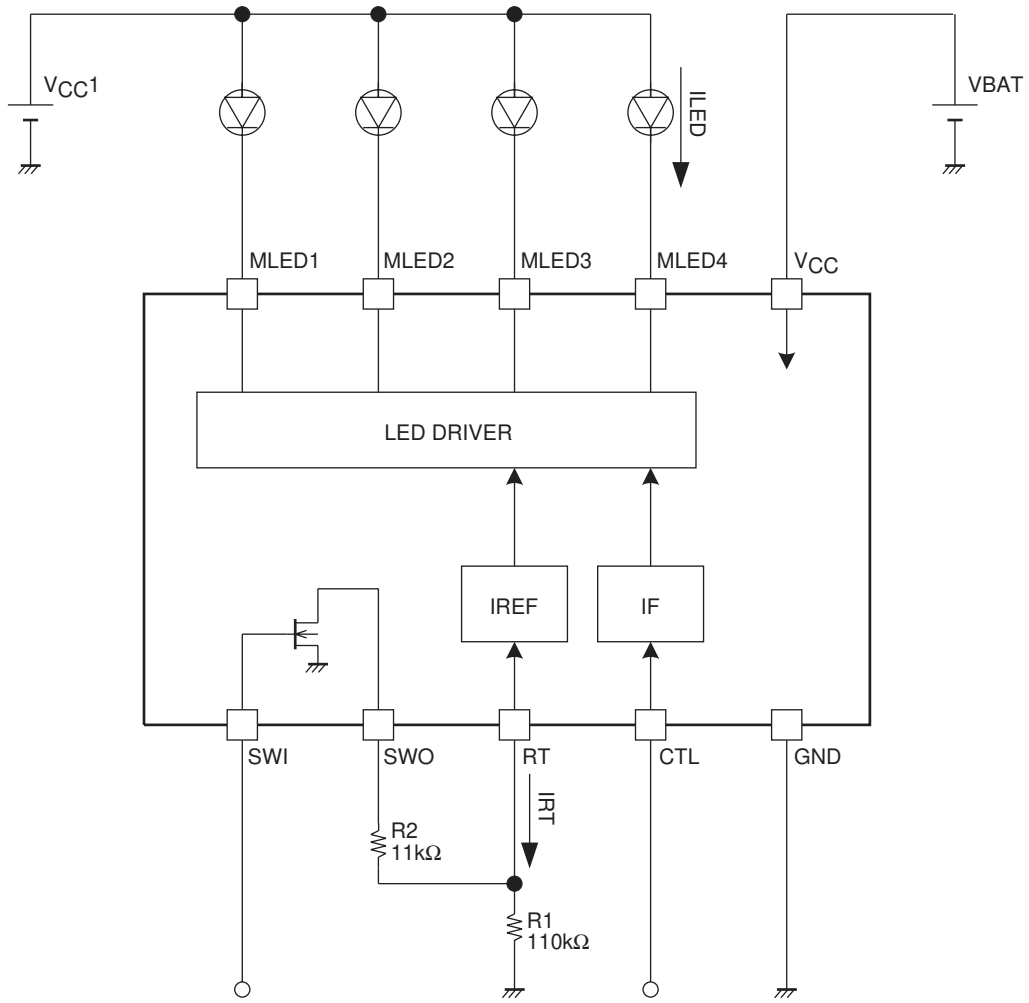

$$I_{LED} = 200 \times I_{RT}$$

LV5215LF

Pin Equivalent Circuit

Pin No.	Pin	Description	Equivalent Circuit
1 2 3 12	MLED3 MLED2 MLED1 MLED4	LED driver pin. Feedback is applied so that the current flowing in the output transistor becomes the set current value.	
11	VCC	Power supply.	
5	CTL	The circuits operate when CTL is high. The circuits stop when CTL is low.	
9	RT	Reference current setting resistor connection. The reference current is created by connecting an external resistor to ground. The pin voltage is about 1.0 V. The LED driver current value can be changed by changing this current value.	
7 8	SWI SWO	Current adjustment. The output current can be adjusted using the SWO pin sink current.	

- SANYO Semiconductor Co.,Ltd. assumes no responsibility for equipment failures that result from using products at values that exceed, even momentarily, rated values (such as maximum ratings, operating condition ranges, or other parameters) listed in products specifications of any and all SANYO Semiconductor Co.,Ltd. products described or contained herein.
- SANYO Semiconductor Co.,Ltd. strives to supply high-quality high-reliability products, however, any and all semiconductor products fail or malfunction with some probability. It is possible that these probabilistic failures or malfunction could give rise to accidents or events that could endanger human lives, trouble that could give rise to smoke or fire, or accidents that could cause damage to other property. When designing equipment, adopt safety measures so that these kinds of accidents or events cannot occur. Such measures include but are not limited to protective circuits and error prevention circuits for safe design, redundant design, and structural design.
- In the event that any or all SANYO Semiconductor Co.,Ltd. products described or contained herein are controlled under any of applicable local export control laws and regulations, such products may require the export license from the authorities concerned in accordance with the above law.
- No part of this publication may be reproduced or transmitted in any form or by any means, electronic or mechanical, including photocopying and recording, or any information storage or retrieval system, or otherwise, without the prior written consent of SANYO Semiconductor Co.,Ltd.
- Any and all information described or contained herein are subject to change without notice due to product/technology improvement, etc. When designing equipment, refer to the "Delivery Specification" for the SANYO Semiconductor Co.,Ltd. product that you intend to use.
- Information (including circuit diagrams and circuit parameters) herein is for example only; it is not guaranteed for volume production.
- Upon using the technical information or products described herein, neither warranty nor license shall be granted with regard to intellectual property rights or any other rights of SANYO Semiconductor Co.,Ltd. or any third party. SANYO Semiconductor Co.,Ltd. shall not be liable for any claim or suits with regard to a third party's intellectual property rights which has resulted from the use of the technical information and products mentioned above.

This catalog provides information as of October, 2010. Specifications and information herein are subject to change without notice.