

**ServiceGrade®  
Hand Crimp Tool**



**Application Tooling  
Specification Sheet**



**Order No. 64016-0204**

**FEATURES**

- A full cycle ratcheting hand tool ensures complete crimps
- Ergonomic soft grip handles for comfortable crimping
- For crimps conforming to WHMA-IPCA620 Class 2, use hand crimp tools 63811-3200, 63811-6800, 63811-7000, and/or 63811-7100

**SCOPE**

Products: See Charts Below.

<b>OEM equivalent Hand Crimp Tool: 63811-3200 14-24 AWG</b>									
<b>Products:</b> 2.36mm (.093") Diameter, Standard .093" Pin and Socket Crimp Terminals, Commoning Connector Crimp Terminals, Claspon™ Crimp Terminal Socket, and 3.18mm (.125") Diameter HCS-125 Pin and Socket Crimp Terminals.									
Terminal Series No.	Terminal Order No.			Wire Size		Insulation Diameter		Strip Length	
	Loose Piece		*Reel	AWG	mm²	mm	In.	mm	In.
1189	02-09-1102	02-09-5111	39-00-0291	14-20	2.08-0.52	1.65-4.06	.065-.160	3.30-3.80	.130-.150
	02-09-1104	39-00-0072	39-00-0294						
	02-09-3102	39-00-0135	39-00-0295						
	02-09-3104	39-00-0288	50-29-1617						
	02-09-5106	39-00-0289							
1190	02-09-2103	02-09-6110	39-00-0299	14-20	2.08-0.52	1.65-4.06	.065-.160	3.30-3.80	.130-.150
	02-09-4104	39-00-0106	39-00-0301						
	02-09-6106	39-00-0297							
1380	02-09-2118	02-09-6126	39-00-0304	18-22	0.82-0.32	1.52-3.05	.060-.120	3.30-3.80	.130-.150
	02-09-2119	39-00-0302	39-00-0306						
	02-09-6123								
1381	02-09-1118	39-00-0307	39-00-0313	18-22	0.82-0.32	1.52-3.05	.060-.120	3.30-3.80	.130-.150
	02-09-1119	39-00-0308	39-00-0314						
	02-09-5133	39-00-0310	40-01-1191						
	02-09-5142								
1457-1	05-02-0048		05-02-0047	18-22	0.82-0.32	1.55-2.59	.061-.102	3.30-3.80	.130-.150
	05-02-0057		05-02-0056						
			05-02-0058						
1457-2	05-02-0050		05-02-0049	14-16	2.08-0.82	3.56 Max.	.140 Max.	3.30-3.80	.130-.150
1881-2	02-08-1102			16-24	1.31-0.32	3.51 Max.	.138 Max.	3.30-3.80	.130-.150
1973	02-09-8104			18-22	0.82-0.32	3.51 Max.	.138 Max.	3.30-3.80	.130-.150
1973-2	02-09-8109			14-18	2.08-1.31	4.06 Max.	.160 Max.	3.30-3.80	.130-.150
2046	18-12-2222			16-18	2.08-1.31	3.05 Max.	.120 Max.	3.30-3.80	.130-.150
2047	18-12-1222			16-18	2.08-1.31	3.05 Max.	.120 Max.	3.30-3.80	.130-.150
2273	02-09-1123	02-09-1140		18-22	0.82-0.32	1.52-3.05	.060-.120	3.30-3.80	.130-.150
2282	18-09-2804	18-09-2807		14-18	2.08-0.82	3.56 Max.	.140 Max.	3.60-4.10	.140-.160
4272	02-09-1149			18-22	0.82-0.32	1.52-3.05	.060-.120	3.30-3.80	.130-.150

OEM equivalent Hand Crimp Tool: 63811-3200 14-24 AWG										
Products: 2.36mm (.093") Diameter, Standard .093" Pin and Socket Crimp Terminals, Commoning Connector Crimp Terminals, Claspon™ Crimp Terminal Socket, and 3.18mm (.125") Diameter HCS-125 Pin and Socket Crimp Terminals.										
Terminal Series No.	Terminal Order No.				Wire Size		Insulation Diameter		Strip Length	
	Loose Piece		*Reel		AWG	mm²	mm	In.	mm	In.
4549	02-09-2167				14-20	2.08-0.52	3.56 Max.	.140 Max.	3.30-3.80	.130-.150
4550	02-09-1206	02-09-5170			14-20	2.08-0.52	3.56 Max.	.140 Max.	3.30-3.80	.130-.150
6310	02-09-1211	02-09-5206			14-20	2.08-0.52	1.65-4.06	.065-.160	3.30-3.80	.130-.150
6271	02-09-1212				18-22	0.82-0.32	1.52-3.05	.060-.120	3.30-3.80	.130-.150
7238	02-09-1112				14-18	2.08-0.82	3.56 Max.	.140 Max.	3.60-4.10	.140-.160

\*Customer to cut off terminal from reel using the Cut-off Tab dimension from the terminals selected.

OEM equivalent Hand Crimp Tool: 63811-6800										
Products: MLX™ Pin and Socket Crimp Terminal 14 - 20 AWG.										
Terminal Series No.	Terminal Order No.				Wire Size		Insulation Diameter Maximum		Strip Length	
	Loose Piece		*Reel		AWG	mm²	mm	In.	mm	In.
42023	02-08-2004	02-08-2010	02-08-2003	02-08-2009	14-20	2.00-0.50	1.52-3.30	.060-.130	3.96-5.53	.156-.218
	02-08-2006	02-08-2012	02-08-2005	02-08-2011						
	02-08-2008		02-08-2007							
42024	02-08-1002	02-08-1006	02-08-1001	02-08-1005	14-20	2.00-0.50	1.52-3.30	.060-.130	3.96-5.53	.156-.218
	02-08-1004	02-08-1008	02-08-1003	02-08-1007						

\*Customer to cut off terminal from reel: 0.20mm (.008") maximum Cut-off Tab.

OEM equivalent Hand Crimp Tool: 63811-7000									
Products: Disk Drive Power Connection System Crimp Terminal 14-20 AWG.									
Terminal Series No.	Terminal Order No.			Wire Size		Insulation Diameter		Strip Length	
	Loose Piece	*Reel		AWG	mm²	mm	In.	mm	In.
8980	02-08-1202	02-08-1201	14-20	2.00-0.50	3.56 Max.	.140 Max.	4.75-5.54	.187-.218	

\*Follow the Cut-Off Tab specifications on Applicator specification sheets.  
 These Terminals cannot be removed from the reel by manual cutting.  
 An applicator must be used or the terminals will not function properly.

OEM equivalent Hand Crimp Tool: 63811-7100									
Products: .093" Pin and Socket 14-18 AWG and 24-30 AWG and Claspon™ Crimp Terminal Socket 14-18 AWG.									
Terminal Series No.	Terminal Order No.			Wire Size		Insulation Diameter		Strip Length	
	Loose Piece	*Reel		AWG	mm²	mm	In.	mm	In.
42477		02-09-1615		14-18	2.00-0.80	2.36-3.55	.093-.140	3.96-5.53	.156-.218
42478	02-09-2612	02-09-2611	02-09-2613	14-18	2.00-0.80	2.36-3.55	.093-.140	3.96-5.53	.156-.218

\*Customer to cut off terminal from reel: 0.25mm (.010") maximum Cut-off Tab.

### CRIMPING INFORMATION:

Crimp the terminal and appropriate gauge wire in the specified profile.

Terminal Series No	Wire Size		Pull Force Minimum ▼		Tool Crimp Profile		
	AWG	mm <sup>2</sup>	N	Lb.	A	B	C
8058, 42023, 42024	20	0.52	58	13	■		
2273, 4272, 6271	20	0.52	62	14	■		
1189, 1190, 1380, 1381, 1457, 1881, 4549, 4550	20	0.52	67	15	■		
8980	20	0.52	71	16	■		
1973	20	0.52	80	18	■		
1881	22	0.35	34	7.5	■		
8058	22	0.35	36	8	■		
2273, 4272, 6271	22	0.35	45	10	■		
1380, 1381, 1457, 1973	22	0.35	53	12	■		
1881	24	0.20	33	7.5	■		
2273, 4272, 6271, 8058, 2023, 42024, 42477, 42478, 8980	18	0.96	89	20		■	
1189, 1190, 1380, 1381, 1457, 1973, 2046, 2047, 2282, 4549, 4550, 7238, 42824, 42825	18	0.96	111	25		■	
8980, 42023, 42024, 42477, 42478	16	1.23	133	30			■
1189, 1190, 1457, 1881, 1973, 2046, 2047, 2282, 4549, 4550, 7238			155	35			■
1189, 1190, 1457, 1973, 2282, 4549, 4550, 7238	14	1.94	178	40			■
42023, 42024, 42477, 42478			222	50			■
8980			267	60			■

▼ Pull force test samples should not have the wire insulation crimped.

### OPERATION

**CAUTION:** Install only Molex terminals listed above with this tool. Do not crimp hardened objects as damage can occur to the tool or die.

Open the hand tool by squeezing the handles together; at the end of the closing stroke the anti-backup ratchet will release. Release the handles and the hand tool will open.

#### Crimping Terminals

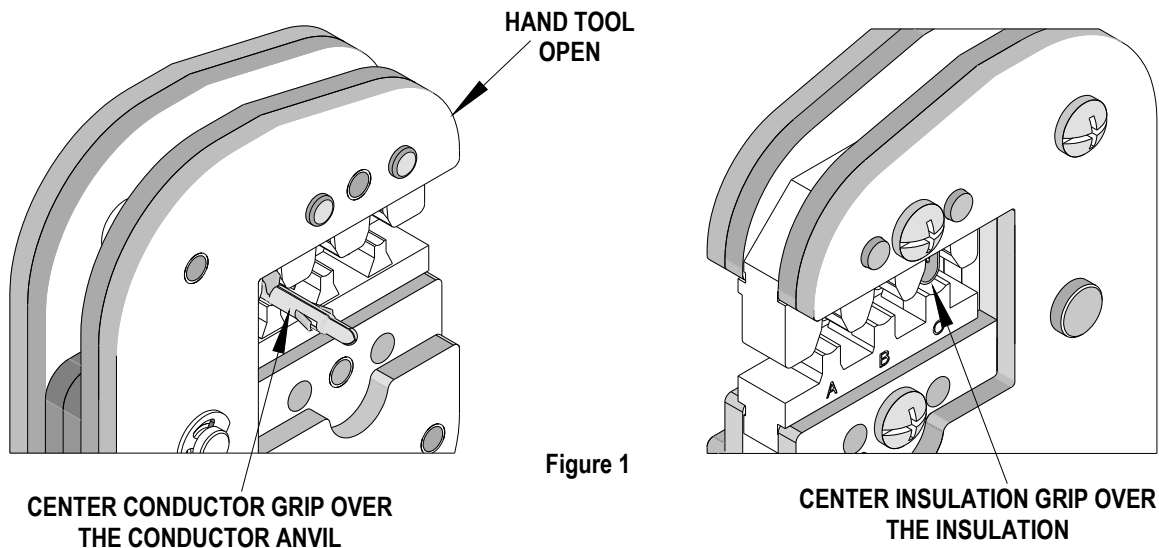

Figure 1

1. Select the desired terminal listed in the preceding charts.
2. Holding the terminal at the contact end, place the terminal on the appropriate anvil. See Figure 1.
3. Slowly close the handles of the tool until the terminal is held in place. If the handles are closed too far the terminal will begin to crimp.
4. Place a pre-stripped wire into the terminal (see Scope chart for recommended strip lengths). Position the wire so the conductor lies in the conductor grip. See Figure 2.
5. While holding the wire in place, slowly close the handles of the tool. If a jam occurs, stop closing the tool and release the anti-backup ratchet by lifting up the lever near the top of the moving handle. See Figure 3.

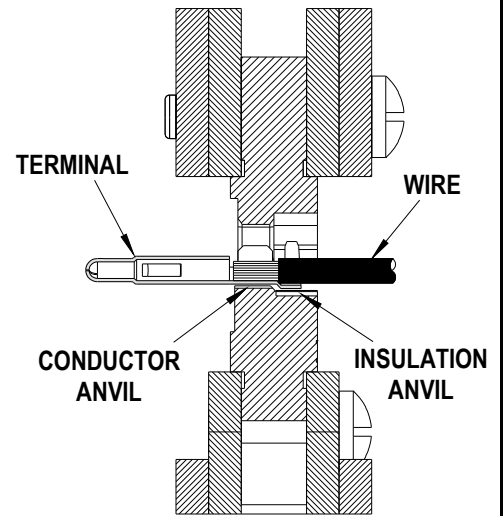
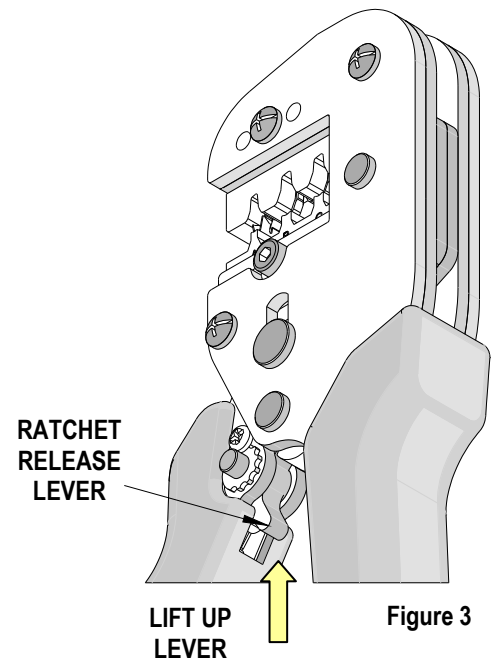

Figure 2

6. Continue to close the tool handles until the anti-backup ratchet releases. Allow the handles to open.
7. Remove the crimped terminal from the tool.
8. Inspect the crimp for loose wire strands, missing crimp, or other damage. Any minor terminal bending may be straightened by hand.

**Note:**

An occasional, destructive, pull force test with the terminal and wire crimped should be performed to check hand tool crimp. The pull force value must exceed the terminal’s minimum pull force specifications listed on page 2. If values do not exceed the minimum pull force when all instructions are followed then a new tool is required.



**Maintenance**

It is recommended that each operator of the tool be made aware of, and responsible for, the following maintenance steps:

1. Remove dust, moisture, and other contaminants with a clean brush, or soft, lint free cloth.
2. Do not use any abrasive materials that could damage the tool.
3. Make certain all pins; pivot points and bearing surfaces are protected with a thin coat of high quality machine oil. Do not oil excessively. Light oil (such as SAE30W oil) applied at the oil points, shown in Figure 4, every 5,000 crimps or 3 months, is recommended.
4. Wipe excess oil from hand tool, particularly from crimping area. Oil transferred from the crimping area onto certain terminations may affect the electrical characteristics of an application.

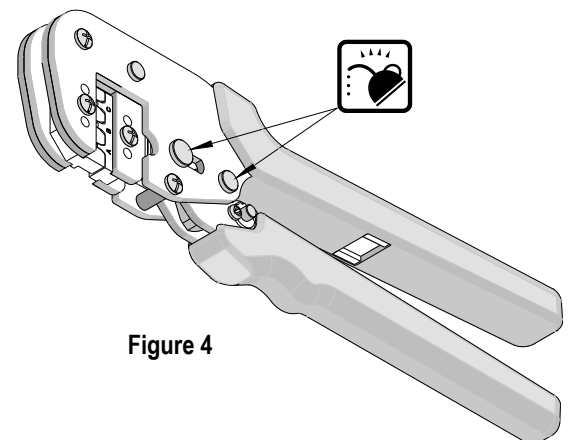

5. When tool is not in use, keep the handles closed to prevent objects from becoming lodged in the crimping dies, and store the tool in a clean, dry area.

## Miscrimps or Jams

If the tool ever becomes jammed in a partially closed position, **DO NOT** force the handles open or closed. The tool will open by lifting the ratchet release lever. See Figure 3.

## Tool Handle Preload

Tool handle preload cannot be adjusted.

This hand tool is set to a preload that will fully close the tool jaws without excessive force from the operator. Over the life of the tool the tool linkage can wear and handle preload force may decrease. It is the operator's responsibility to periodically perform a tensile pull test on the crimped wire. If the pull test value falls below specification, the tool should be replaced.

## Warranty

This tool is for electrical terminal crimping purposes only. All tools are warranted to be free of manufacturing defects for a period of 30 days. Should such a defect occur, the tool will be exchanged free of charge. This exchange will not be applicable to altered, misused, or damaged tools. This tool is designed for hand use only. Any clamping, fixturing, or use of handle extensions voids this warranty.

**CAUTION:** Molex crimp specifications are valid only when used with Molex terminals and tooling.

## CAUTIONS:

1. Manually powered hand tools are intended for low volume or field repair. This tool is **NOT** intended for production use. Repetitive use of this tool should be avoided.
2. Insulated rubber handles are not protection against electrical shock. **NEVER** perform crimps on active electrical circuits.
3. Wear eye protection at all times.
4. Use only the Molex terminals specified for crimping with this tool.

## Certification

Molex does not certify or re-certify ServiceGrade™ hand tools but rather supplies the following guidelines for customers to maintain their hand tools.

- % This tool is qualified to pull force only. To re-certify, crimp a terminal to a wire, which has been stripped 12.7mm (1/2") long, so there is no crimping of the insulation. Pull the terminal and wire at a rate no faster than 25mm (1.00") per minute. See the Molex web site for the Quality Crimp Handbook for more information on pull testing.
- % When the hand tool is no longer capable of achieving minimum pull force, it should be replaced.

<http://www.molex.com>