

SerialFlash™

Manual

All Mikroelektronika's development systems feature a large number of peripheral modules expanding microcontroller's range of application and making the process of program testing easier. In addition to these modules, it is also possible to use numerous additional modules linked to the development system through the I/O port connectors. Some of these additional modules can operate as stand-alone devices without being connected to the microcontroller.

Additional board

 **MikroElektronika**

SOFTWARE AND HARDWARE SOLUTIONS FOR EMBEDDED WORLD ...making it simple

SerialFlash

The SerialFlash additional board features 8Mbit serial flash memory. Due to a DIP switch and voltage translators provided on the board, it can be easily connected to various 3.3V or 5V development systems.

Key features:

- SPI bus compatible serial interface;
- 8 Mbit of Flash memory;
- 3.3 V or 5 V single supply voltage;
- Bulk Erase (8 Mbit) in 8 s (typical).

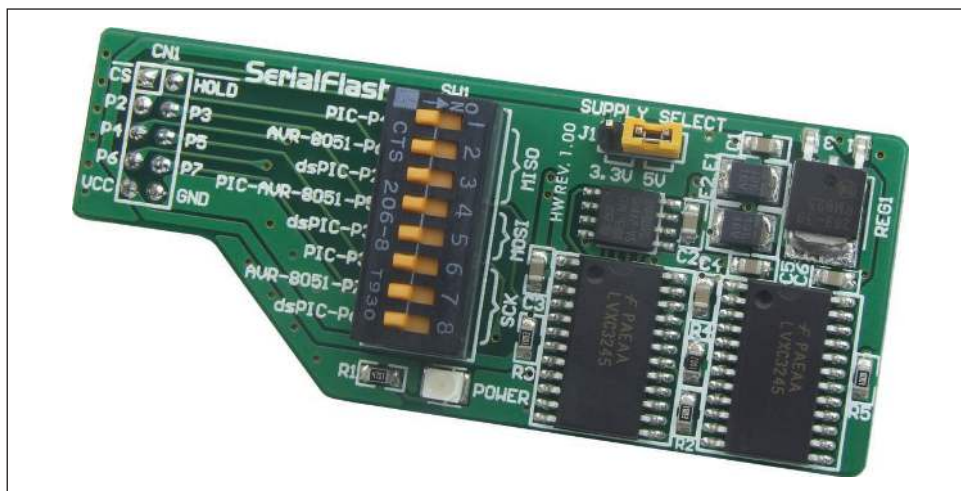

Figure 1: SerialFlash additional board

How to connect the board?

The SerialFlash additional board is connected to a development system via a 2x5 connector CN1 on the additional board and a 2x5 connector on a development system's port. Port selection depends on the arrangement of pins used for SPI communication. Depending on the development system in use, it is necessary to set the appropriate switches on DIP switch SW1 to the ON position, table 1. Jumper J1 is used to select power supply voltage (3.3V or 5V) to be used to power the additional board.

	MISO	MOSI	SCK
PIC	1 (P4)	4 (P5)	6 (P3)
dsPIC	3 (P2)	5 (P3)	8 (P6)
AVR-8051	2 (P6)	4 (P5)	7 (P7)
	Position of switches on DIP switch SW1 for appropriate dev.system		

Table 1

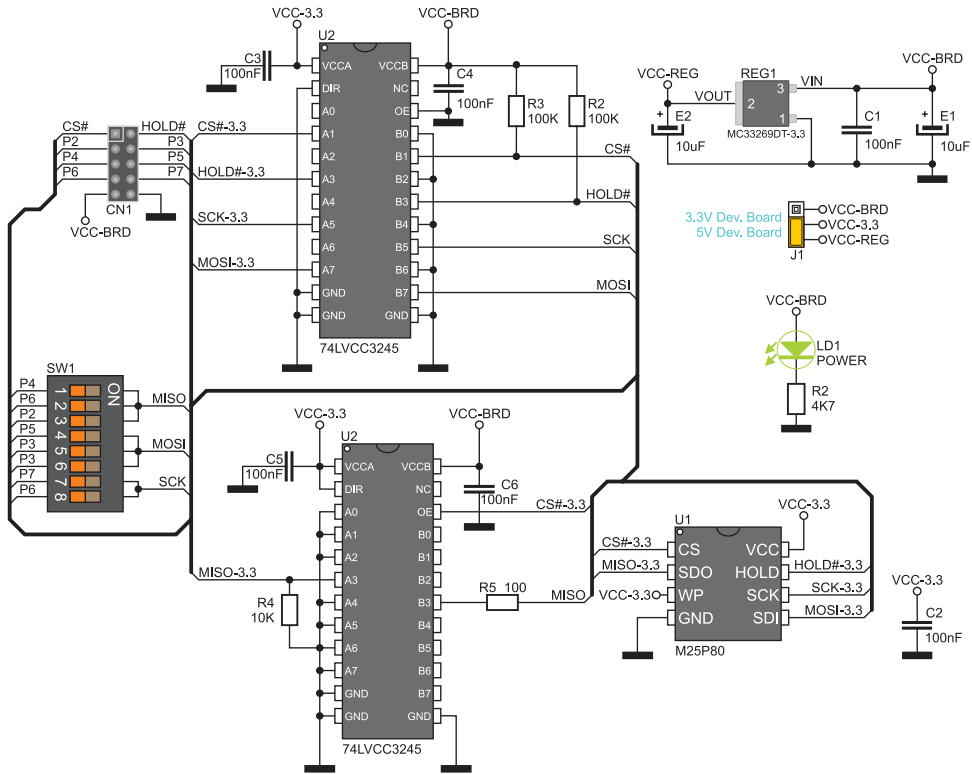

Figure 2: SerialFlash additional board connection schematic

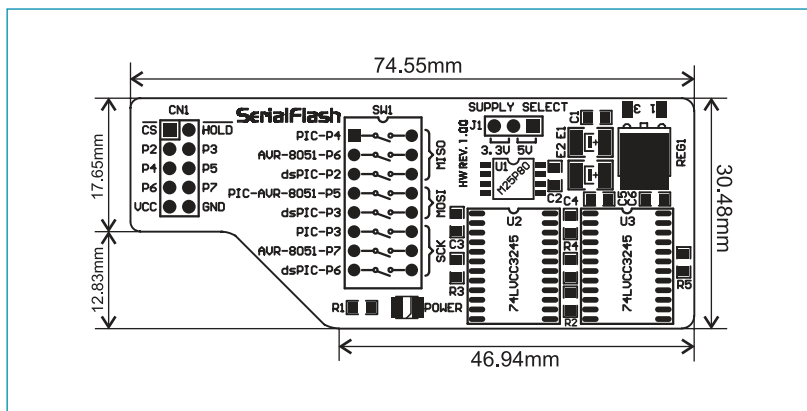

Figure 3: Dimensions of the SerialFlash additional board

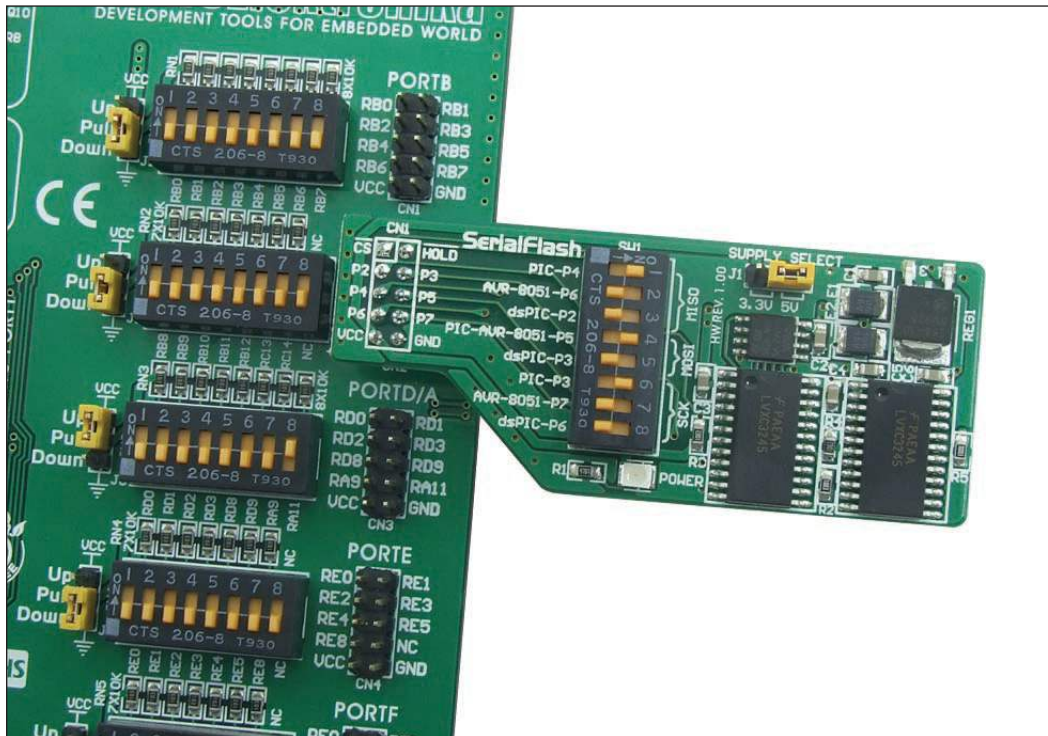

Figure 4: SerialFlash connected to a development system



MikroElektronika
SOFTWARE AND HARDWARE SOLUTIONS FOR EMBEDDED WORLD ...making it simple

If you want to learn more about our products, please visit our website at www.mikroe.com

If you are experiencing some problems with any of our products or just need additional information, please place your ticket at www.mikroe.com/en/support

If you have any questions, comments or business proposals, do not hesitate to contact us at office@mikroe.com