

THIS DRAWING IS UNPUBLISHED. RELEASED FOR PUBLICATION
 © COPYRIGHT - By - ALL RIGHTS RESERVED.

LOC	DIST	REVISIONS			
P	LTR	DESCRIPTION	DATE	DWN	APVD
FT	64	A1	REVISED PER ECO-11-004835	11MAR11	RK HMR

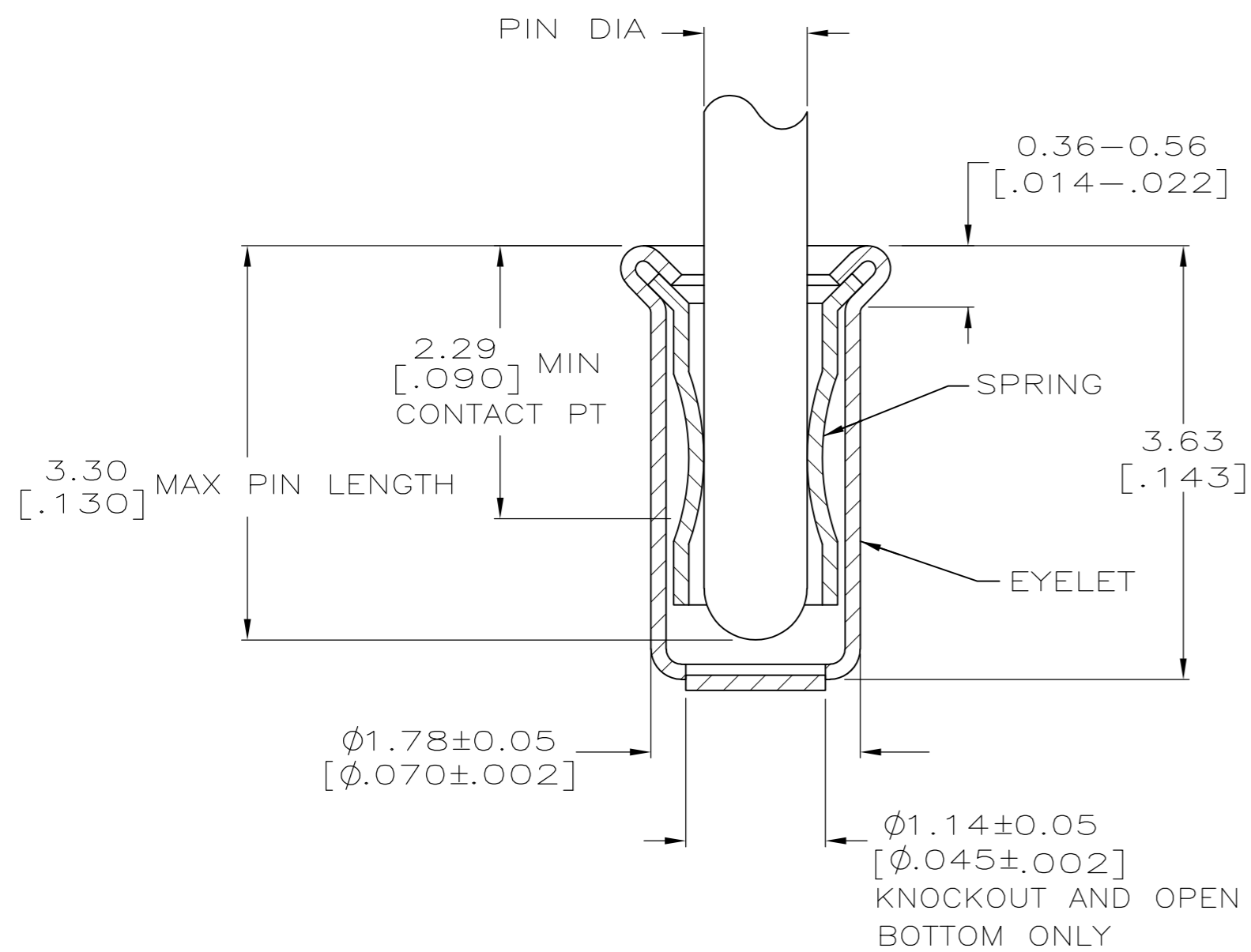
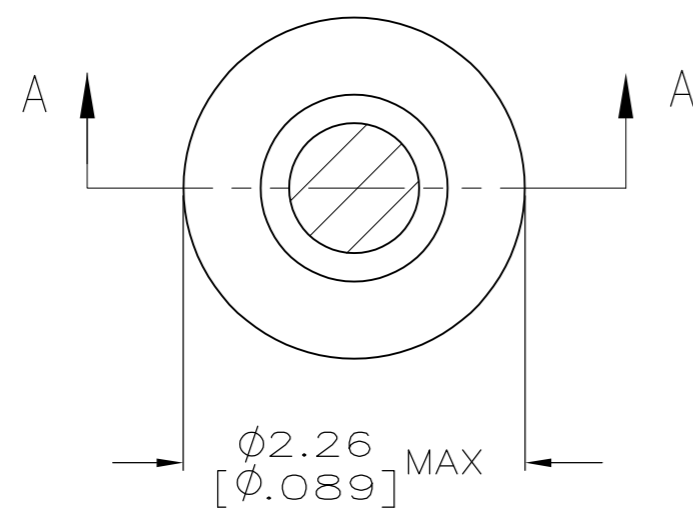

SECTION A-A

- 1. TIN PLATE PER ASTM B 545 0.00254 [.000100] MIN THICK.
- 2. NICKEL UNDERPLATE ALL OVER, MATING SURFACE PLATED TO MEET PERFORMANCE REQUIREMENTS OF TE CONNECTIVITY PRODUCT SPECIFICATION 108-14008.
- 3. RECOMMENDED HOLE SIZE, PLATED OR UNPLATED:
 - MACHINE INSERTION: $1.83^{+0.10}_{-0.08}$ [$.072^{+0.004}_{-0.003}$]
 - HAND INSERTION: $1.83^{+0.10}_{-0.00}$ [$.072^{+0.004}_{-0.000}$]
- 4. APPLICATION TOOL PART NUMBER: MACHINE NO. 682127-5
INSERTION HEAD NO. 682039-4
- 5. TO INSURE PROPER SPRING TENSION DO NOT EXCEED A 0.05 [.002] DIFFERENCE IN PIN DIA WHEN CHANGING TO A SMALLER PIN.
- 6. BOTTOM PLUG KNOCKOUT TOOL PART NUMBER 69729 WITH TIP PART NUMBER 69728-2.
- 7. MATERIAL:
SPRING: BERYLLIUM COPPER PER ASTM B 194
EYELET: COPPER PER ASTM B 152

OBSOLETE

OPEN	0.71-0.84 [.028-.033]	TIN	GOLD	4-5332070-4
KNOCKOUT	0.94-1.02 [.037-.040]		TIN	3-5332070-5
OPEN	0.94-1.02 [.037-.040]	TIN	TIN	2-5332070-9
	0.86-0.94 [.034-.037]		TIN	2-5332070-8
	0.76-0.84 [.030-.033]		GOLD	2-5332070-6
CLOSED	0.94-1.02 [.037-.040]	TIN	GOLD	2-5332070-5
	0.86-0.94 [.034-.037]		TIN	2-5332070-3
BOTTOM TYPE	RECOMMENDED PIN DIA	EYELET	GOLD	2-5332070-2
			SPRING	2-5332070-1
			FINISH	PART NO

THIS DRAWING IS A CONTROLLED DOCUMENT.		DWN	22APR2005	TE Connectivity	
		CHK	A. FERNANDEZ-DOCK5		
		APVD	J. HAVENER		
		PRODUCT SPEC	108-14008		
		APPLICATION SPEC	114-13152		
		WEIGHT	-		
		CUSTOMER DRAWING			
DIMENSIONS:	TOLERANCES UNLESS OTHERWISE SPECIFIED:				
INCHES	0 PLC ± -				
	1 PLC ± -				
	2 PLC ± -				
	3 PLC ± 0.20 [.008]				
	4 PLC ± -				
	ANGLES ± -				
MATERIAL	FINISH				
1	SEE TABLE				
		SIZE	CAGE CODE	DRAWING NO	RESTRICTED TO
		A2	00779	C=5332070	-
		SCALE	SHEET	REV	
		20:1	1 of 1	A1	