

PHOTONIC DETECTORS INC.

Silicon Photodiode, Blue Enhanced Photoconductive Hermetic Fiber Optic Detector Type PDB-C502-FC

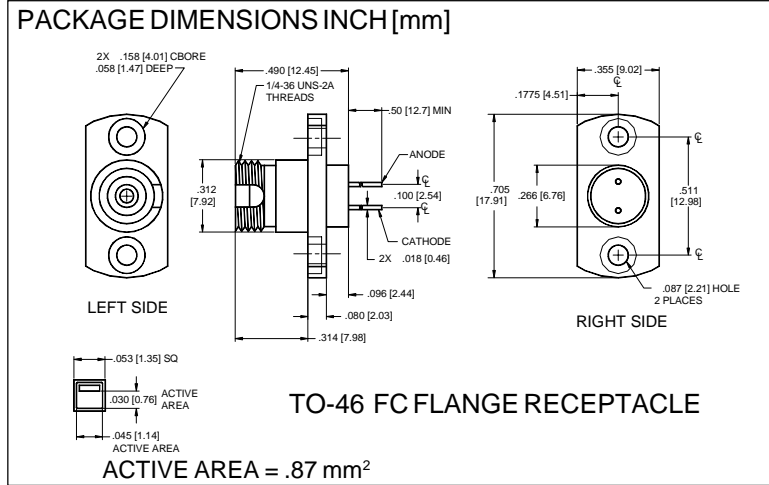

FEATURES

- High speed
- Low capacitance
- Blue enhanced
- Low dark current

DESCRIPTION

The **PDB-C502-FC** is a silicon, PIN planar diffused, blue enhanced photodiode. Ideal for high speed photoconductive applications. Packaged in a hermetic, TO-46 FC flange mount receptacle.

APPLICATIONS

- Industrial controls
- Video systems
- Laser power monitors
- Fiber optic links

ABSOLUTE MAXIMUM RATING (TA=25°C unless otherwise noted)

SYMBOL	PARAMETER	MIN	MAX	UNITS
V_{BR}	Reverse Voltage		100	V
T_{STG}	Storage Temperature	-55	+150	°C
T_O	Operating Temperature Range	-40	+125	°C
T_S	Soldering Temperature*		+240	°C
I_L	Light Current		0.5	mA

*1/16 inch from case for 3 secs max

SPECTRAL RESPONSE

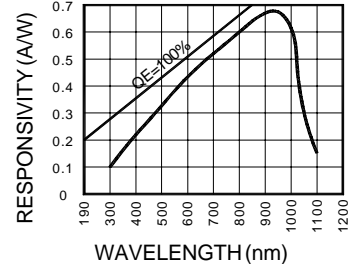

ELECTRO-OPTICAL CHARACTERISTICS (TA=25°C unless otherwise noted)

SYMBOL	CHARACTERISTIC	TEST CONDITIONS	MIN	TYP	MAX	UNITS
I_{SC}	Short Circuit Current	H = 100 fc, 2850 K	8.5	9		mA
I_D	Dark Current	H = 0, $V_R = 10$ V		45	150	pA
R_{SH}	Shunt Resistance	H = 0, $V_R = 10$ mV	0.5	2		GΩ
TCR_{SH}	RSH Temp. Coefficient	H = 0, $V_R = 10$ mV		-8		% / °C
C_J	Junction Capacitance	H = 0, $V_R = 10$ V**		4		pF
λ_{range}	Spectral Application Range	Spot Scan	350		1100	nm
λ_p	Spectral Response - Peak	Spot Scan		950		nm
V_{BR}	Breakdown Voltage	I = 10 mA	100	125		V
NEP	Noise Equivalent Power	$V_R = 10$ V @ Peak		10×10^{-14}		W / \sqrt{Hz}
tr	Response Time	RL = 1 KΩ $V_R = 50$ V		3.0		nS

Information in this technical data sheet is believed to be correct and reliable. However, no responsibility is assumed for possible inaccuracies or omission. Specifications are subject to change without notice. ** f = 1 MHz [FORM NO. 100-PDB-C502-FC REV N/C]