

### **3. PRODUCT INFORMATION**

#### **3.1. Description**

**FY07024DI26A67-FT is a color active matrix LCD module incorporating amorphous silicon TFT (Thin Film Transistor). It is composed of a color TFT-LCD panel, driver ICs, FPC and a backlight unit. The 7.0' ' display area contains 1024 (RGB) x 600 pixels**

#### **3.2. Applications**

- UMPC**
- Portable DVD**
- GPS**
- MID**

#### **3.3. Features**

- High Resolution:1024(RGB) x 600 Dots**
- adopting a high aperture ratio**
- 24 chip LED backlight**
- Dot-Inversion**

## 4. General Specifications

NO.	ITEM	SPECIFICATION	UNIT	REMARK
1	LCD size	7.0 (Diagonal)	inch	
2	Driver Method	a-si TFT active matrix	–	
3	Resolution	1024 × 3(RGB) × 600	dots	
4	Display mode	Normally Black, FFS	–	
5	Dot pitch	0.1506(H) × 0.1432(V)	mm	
6	Active area	154.21(H) × 85.92(V)	mm	
7	Panel size	163.64 (H) × 96.84(V) ×2.6(T)	mm	
8	Color Pixel	RGB vertical stripe	–	
9	Surface treatment	Anti-Glare	–	
10	View Direction	All	–	
11	Interface	RGB	–	

# 5. Mechanical drawing

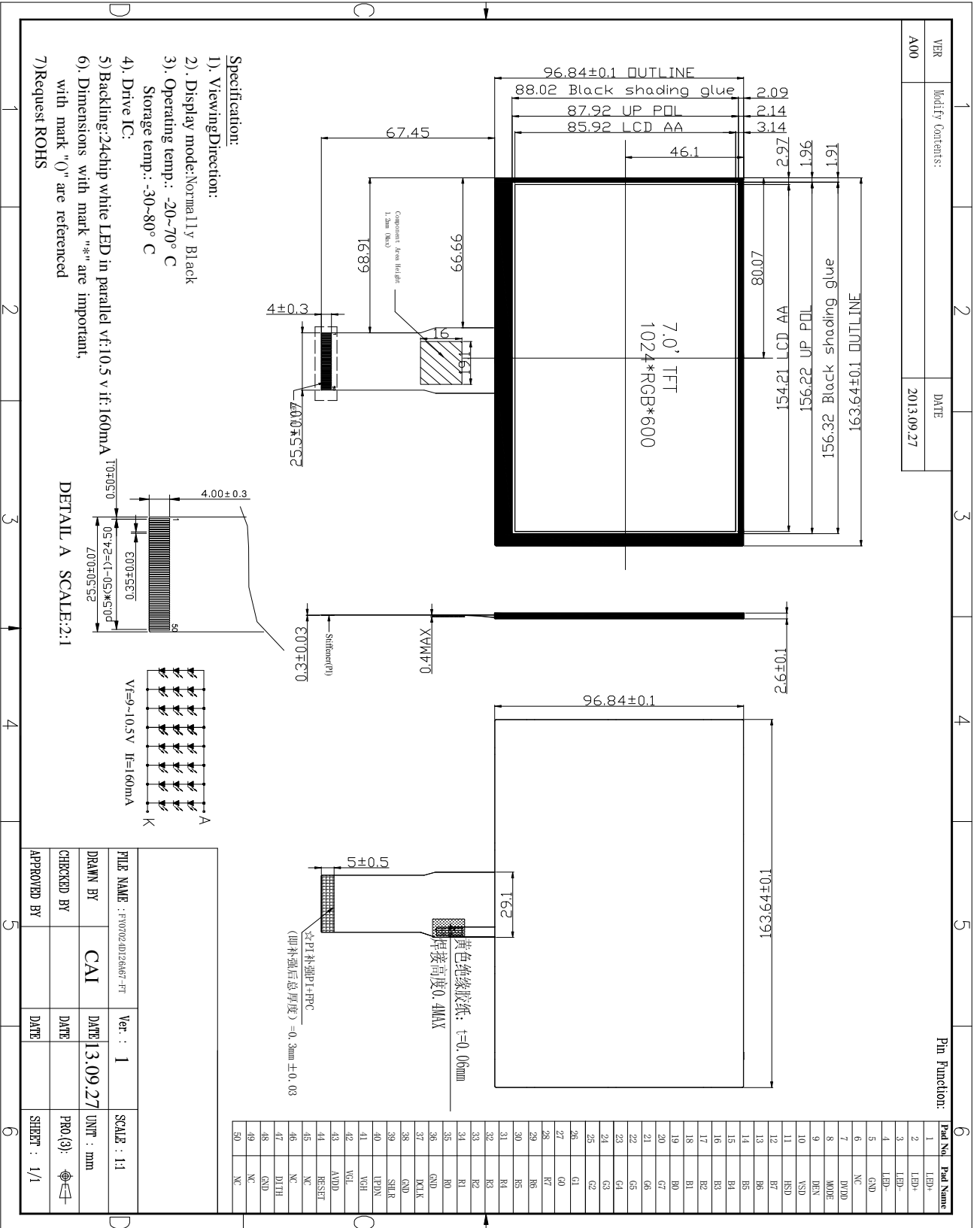

## 6. ABSOLUTE MAXIMUM RATINGS

The following are maximum values which, if exceeded, may cause faulty operation or damage to the unit.

Item	Symbol	Min.	Max.	Unit	Note
Digital Supply Voltage	DVDD	-0.3	3.96	V	-
Analog Supply Voltage	AVDD	-0.5	14.85	V	-
Gate On Voltage	VGH	-0.3	40	V	-
Gate Off Voltage	VGL	-20	0.3	V	-
Gate On-Gate Off Voltage	VGH-VGL	12	40	V	-
Operating Temperature	Topa	-20	70	°C	Note1
Storage Temperature	Tstg	-30	80	°C	Note1

Note1 : If users use the product out off the environmental operation range ( temperature and humidity,it will have visual quality concerns.

## 7.ELECTRICAL CHARACTERISTICS

### 7.1 Typical Operation Conditions

Ta=25°C

ITEM	SYMBOL	MIN	TYP	MAX	UNIT	NOTE
Digital Power Supply Voltage For LCD	DVDD	3	3.3	3.6	V	-
Analog Power Supply Voltage	AVDD	9.4	9.6	9.8	V	-
Gate On Power Supply Voltage	VGH	17	18	19	V	-
Gate Off Power Supply Voltage	VGL	-6.6	-6	-5.4	V	-
Logic Input Voltage	VIH	0.7*DVDD	-	DVDD	V	-
	VIL	GND	-	0.3*DVDD	V	

### 7.2 TFT-LCD Current Consumption

ITEM	SYMBOL	CONDITION	MIN	TYPE	MAX	UNIT	NOTE
Gate On Power Current	IVGH	VGH = 18V	--	0.5	1	mA	Note1
Gate Off Power Current	IVGL	VGL = -6V	--	0.5	1	mA	Note1
Digital Power Current	IDVDD	DVDD = 3.3V	--	30	45	mA	Note1
Analog Power Current	IAVDD	AVDD = 9.6V	--	35	45	mA	Note1
Total Power Consumption	PC		--	447	604	mW	Note1

Note1: Typ. specification : Gray-level test Pattern

Max. specification : White test Pattern



256 gray pattern



White Pattern

### 7.3 Power & Signal Sequence

Power On : DVDD→AVDD/VGL →VGH →Video & Logic Signal→Backlight

Power Off : Backlight→Video & Logic Signal→ VGH→AVDD/VGL→DVDD

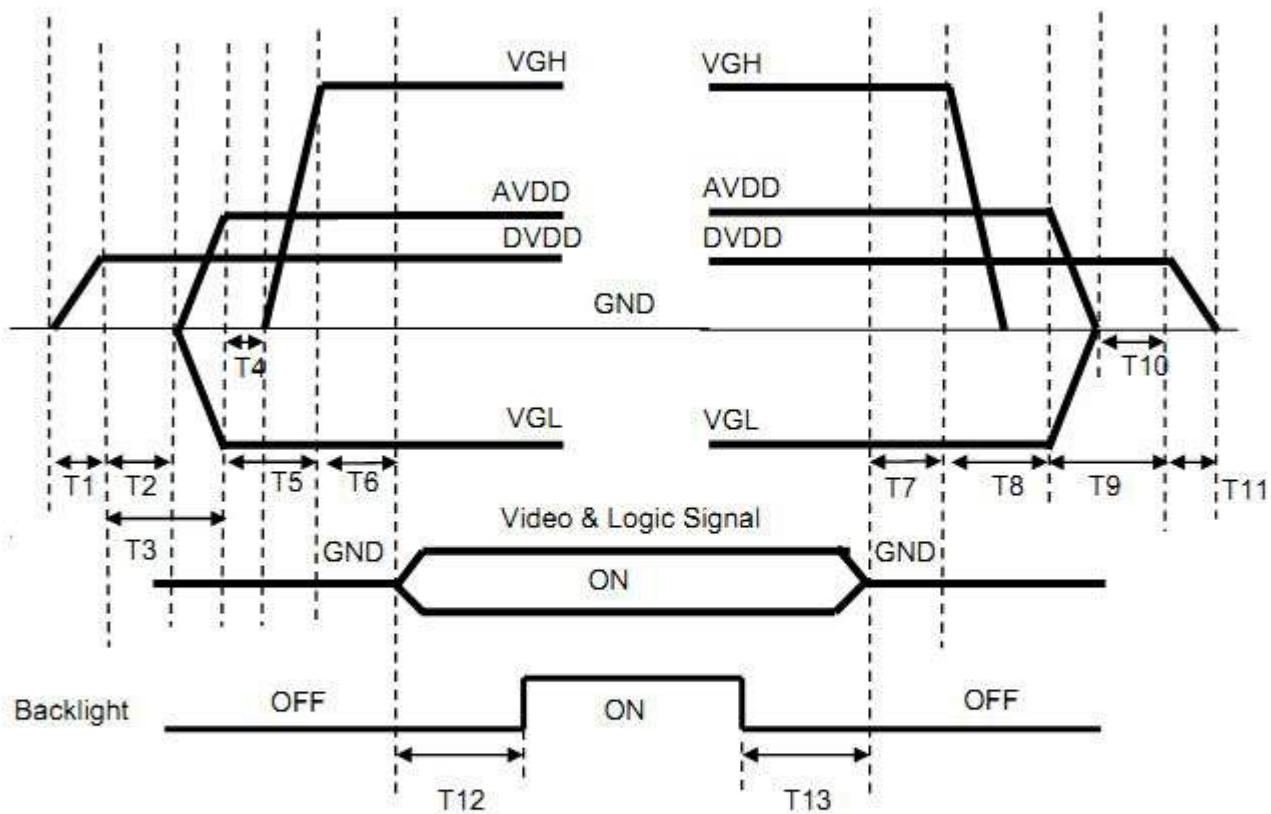

$0 < T1 \leq 10\text{ms}$   
 $T2 > 0\text{ms}$   
 $T3 > 20\text{ms}$   
 $T4 > 0\text{ms}$   
 $T5 > 10\text{ms}$   
 $0 < T6 \leq 10\text{ms}$   
 $T12 \geq 200\text{ms}$

$T7 > 0\text{ms}$   
 $T8 > 0\text{ms}$   
 $T9 > 0\text{ms}$   
 $T10 > 0\text{ms}$   
 $0 < T11 \leq 10\text{ms}$   
 $T13 \geq 200\text{ms}$

## 7.4 Timing Characteristics of Input Signals

### 7.4.1 Input Timing Table

	ITEM	SYMBOL	MIN.	TYP.	MAX.	UNIT	Note
<b>DE MODE</b>	Dot Clock	1/tCLK	45	51.2	57	MHz	
	DCLK Pulse Duty	Tcwh	40	50	60	%	
	Horizontal Total Time	tH	1324	1344	1364	tCLK	
	Horizontal Effective Time	tHA	1024			tCLK	
	Horizontal Blank Time	tHB	300	320	340	tCLK	
	Vertical Total Time	tV	625	635	645	tH	
	Vertical Effective Time	tVA	600			tH	
	Vertical Blank Time	tVB	25	35	45	tH	
<b>SYNC MODE</b>	Horizontal Total Time	TH	1324	1344	1364	tCLK	
	Horizontal Pulse Width	Thpw		20	-	tCLK	thb + thpw =160DCLK is fixed
	Horizontal Back Porch	Thb		140	-	tCLK	
	Horizontal Front Porch	Thfp	140	160	180	tCLK	
	Horizontal Effective Time	THA	1024			tCLK	
	Vertical Total Time	TV	625	635	645	tH	
	Vertical Pulse Width	Tvpw		3	-	th	tvpw + tvb =23th is fixed
	Vertical Back Porch	Tvb	-	20	-	th	
	Vertical Front Porch	Tvfp	2	12	22	th	
Vertical Valid	Tvd	600			th		

## 7.4.2 Input Clock and Data Timing Diagram

Parameter	Symbol	Spec.			Unit	Condition
		Min.	Typ.	Max.		
DVDD Power On Slew Rate	TPOR	-	-	20	ms	From 0V to 90% DVDD
RSTB Pulse Width	TRst	50	-	-	us	DCLK=65MHz
DCLK Cycle Time	Tcph	14	-	-	ns	
DCLK Pulse Duty	Tcwh	40	50	60	%	
VSD Setup Time	Tvst	5	-	-	ns	
VSD Hold Time	Tvhd	5	-	-	ns	
HSD Setup Time	Thst	5	-	-	ns	
HSD Hold Time	Thhd	5	-	-	ns	
Data Setup Time	Tdsu	5	-	-	ns	D0[7:0],D1[7:0],D2[7:0] to DCLK
Data Hold Time	Tdhd	5	-	-	ns	D0[7:0],D1[7:0],D2[7:0] to DCLK
DEN Setup Time	Tesu	5	-	-	ns	
DEN Hold Time	Tehd	5	-	-	ns	

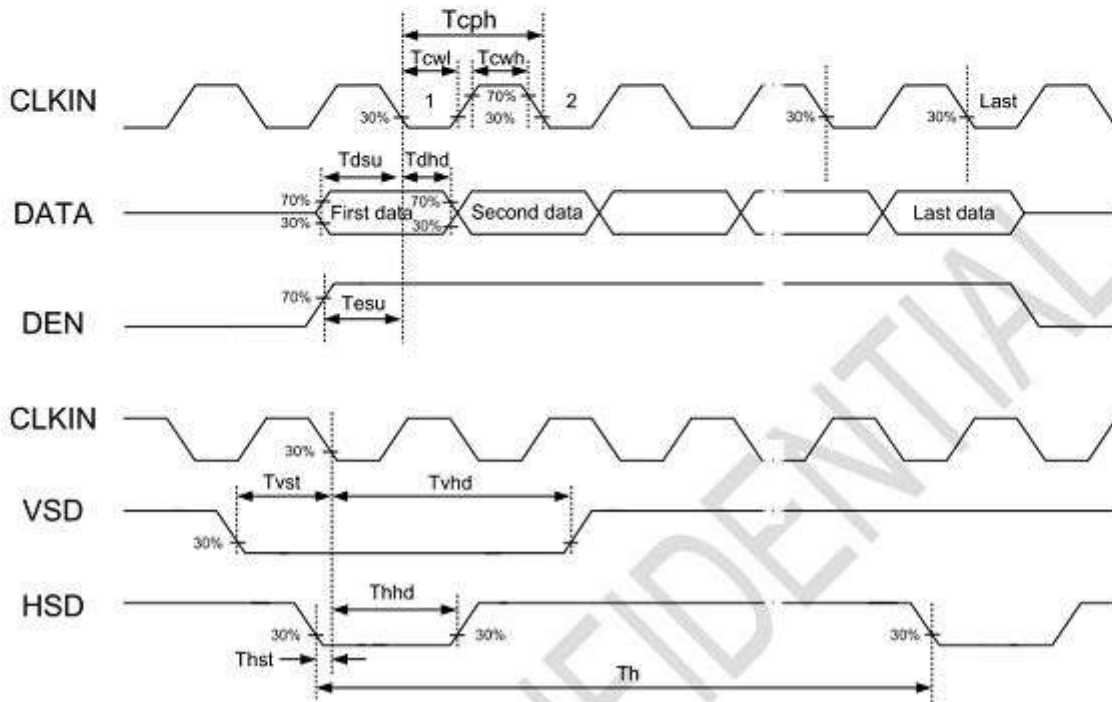



## 7.5 Timing Sequence(Timing Chart)

### 7.5.1 DE Mode

Horizontal timing :

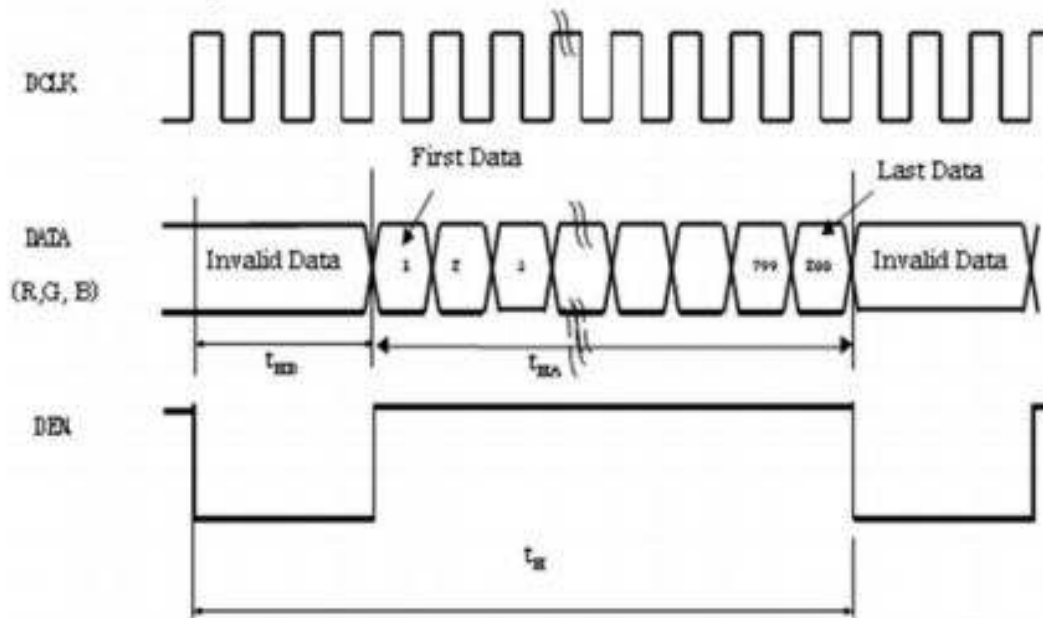

Vertical timing :

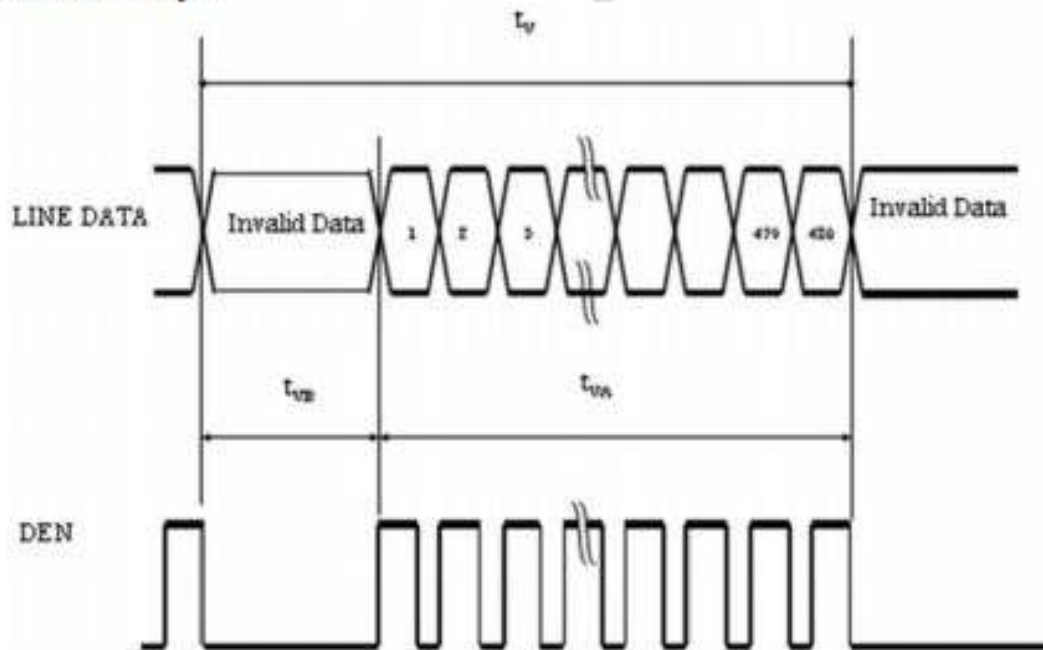

### 7.5.2 SYNC Mode

Horizontal timing :

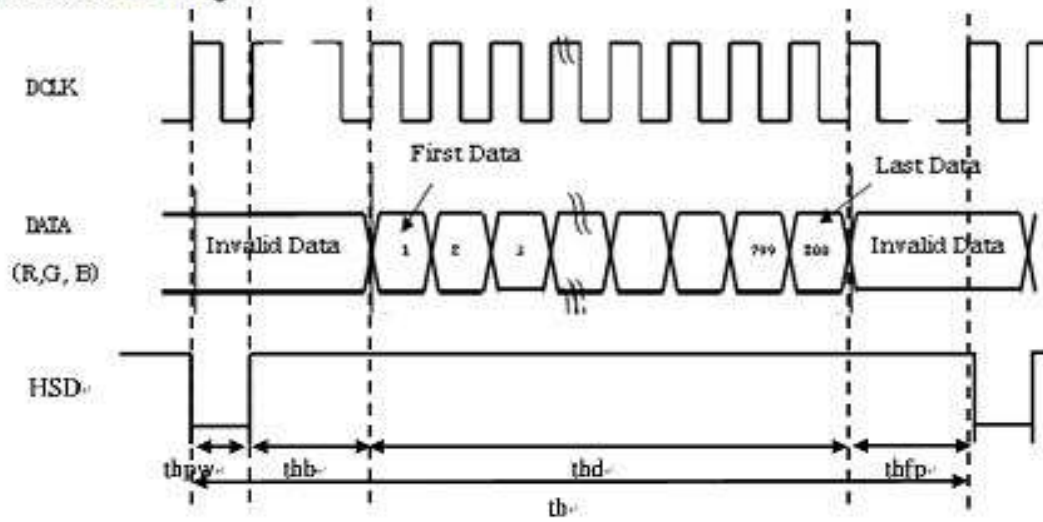

Vertical timing :

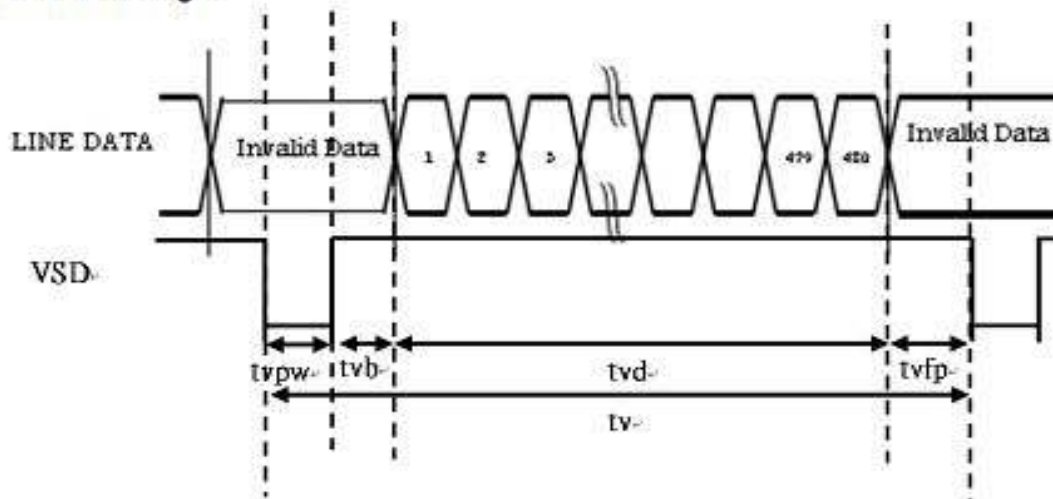

### 7.5.3 Data Input Format

#### Horizontal timing :

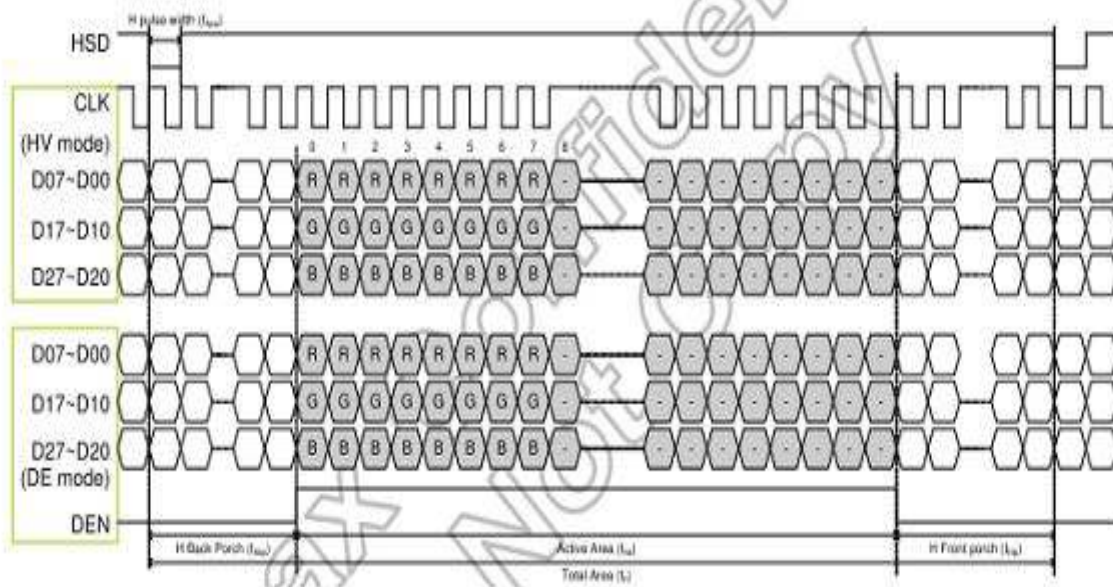

#### Vertical timing :

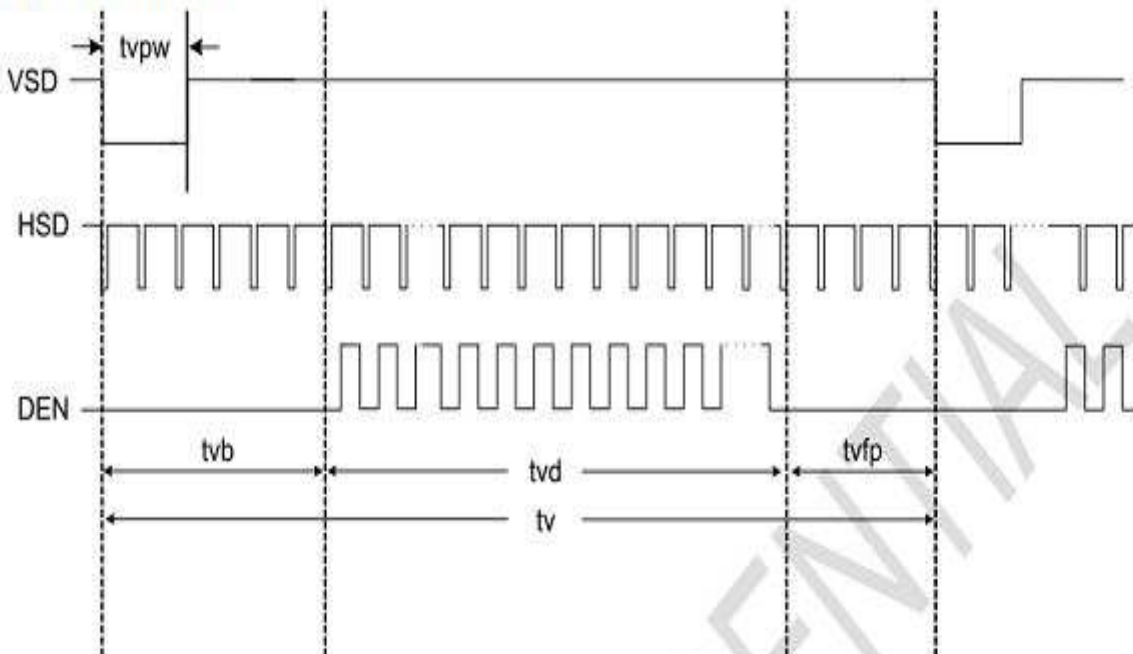

# . OPTICAL CHARACTERISTICS

( Use CPT LED Backlight )

Ta=25°C

ITEM	SYMBOL	CONDITION	MIN.	TYP.	MAX.	UNIT	NOTE
Panel Transmittance	T	--	3.8	4.1	--	%	
Contrast Ratio	CR	Point-5	600	800	--	--	2
Response Time	Tr + Tf	Point-5	--	30	50	ms	3
NTSC			45%	50%	--		
Viewing Angle	Left	$\phi$	Point-5 CR $\geq$ 10	80	85		4
	Right	$\phi$		80	85		4
	Upper	$\theta$		80	85		4
	Lower	$\theta$		80	85		4
Color Filter Chromaticity	White	x	$\theta = \phi = 0^\circ$	0.270	0.290	0.310	
		y		0.311	0.331	0.351	
	Red	x	$\theta = \phi = 0^\circ$	0.612	0.632	0.652	
		y		0.291	0.311	0.331	
	Green	x	$\theta = \phi = 0^\circ$	0.277	0.297	0.317	
		y		0.516	0.536	0.556	
	Blue	x	$\theta = \phi = 0^\circ$	0.120	0.140	0.160	
		y		0.134	0.154	0.174	

Note1: Measure condition : 25°C ± 2°C · 60 ± 10%RH · under 10 Lux in the dark room. BM-5A (TOPCON) · viewing angle 2° · Measurement after lighting on 10 mins.

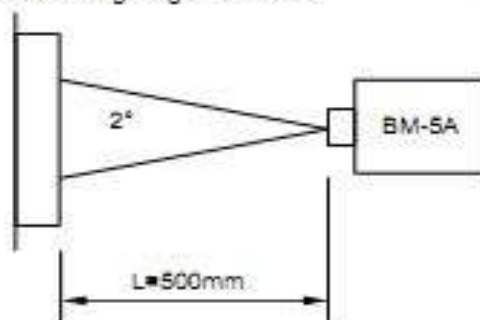

Note2: Definition of contrast ratio :

Contrast Ratio (CR) = (White) Luminance of ON + (Black) Luminance of OFF

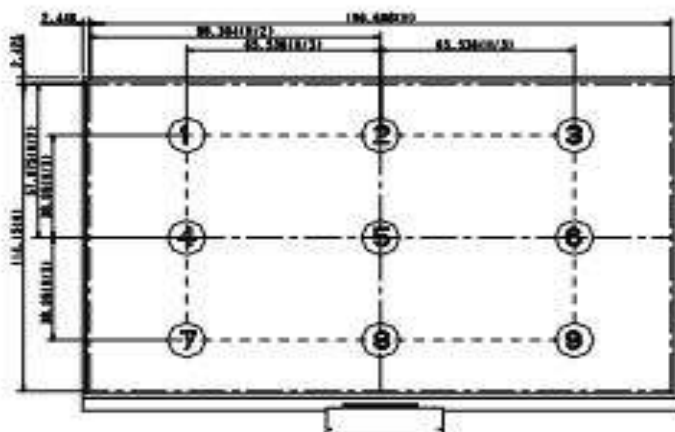

Fig. 6-1 Measuring point

Note 3: Definition of Response Time.(White-Black)

The response time is defined as the time interval between the 10% and 90% amplitudes.

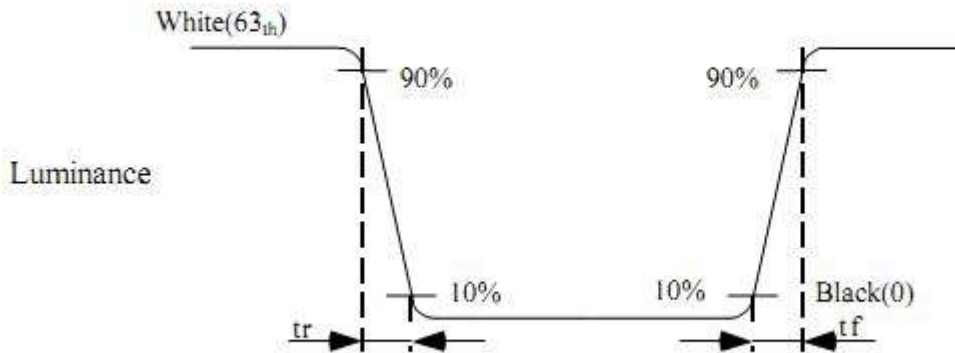

Fig. 6-2 Measuring point

Note 4: Definition of Viewing Angle( $\theta, \psi$ ), refer to Fig.6 as below :

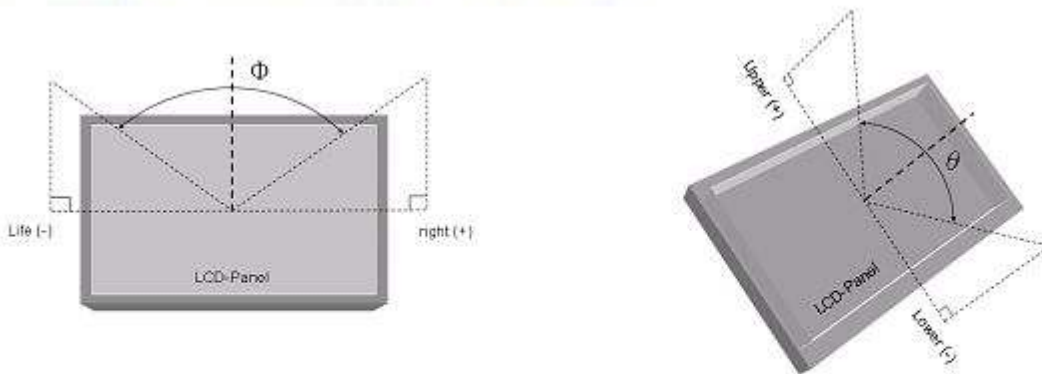

Fig.6-3 Definition of Viewing Angle

## 9. Backlight Driving Section

Item	Symbol	Min.	Typ.	Max.	Unit	Remark
LED Voltage	VF	9	9.8	10.5	V	
LED Current	IF	-	160	-	mA	
Number of LED	--	24			--	

**Note 1:** There are 1 Groups LED

**Note 2:** Ta = 25\_

**Note 3:** Brightness to be decreased to 50% of the initial value

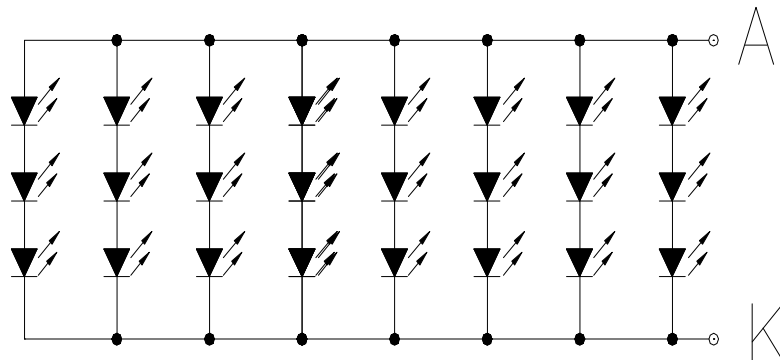

*BLU CIRCUIT DIAGRAM*

## 10. RGB Interface Pin Function

1-2	LED+	LED Anode
3-4	LED-	LED Cathode
5	GND	Ground
6	NC	Not Connect
7	DVDD	Digital Power
8	MODE	DE/SYNC mode select. Normally pull high H: DE mode. L: HSD/VSD mode
9	DEN	Data Enable signal
10	VSD	Vertical sync input. Negative polarity
11	HSD	Horizontal sync input. Negative polarity
12-19	B7-B0	Blue Data Input
20-27	G7-G0	Green Data Input
28-35	R7-R0	Red Data Input
36	GND	Power ground
37	DCLK	Clock input
38	GND	Power ground
39	SHLR	Left or Right Display Control【Note1】

40	UPDN	Up / Down Display Control
41	VGH	Positive Power for TFT
42	VGL	Negative Power for TFT
43	AVDD	Analog Power
44	RESET	Global reset pin. Active low to enter reset state. Suggest to connecting with an RC reset circuit for stability. Normally pull high. (R=10K $\Omega$ , C=1 $\mu$ F)
45	NC	Not connect
46	NC	Not connect
47	DITH	Dithering function enable control. Normally pull low DITHER = "1", Enable internal dithering function DITHER = "0", Disable internal dithering function
48	GND	Power ground
49	NC	Not connect
50	NC	Not connect



【Note1】 SHLR : left or right setting  
UPDN : up or down setting

UPDN	SHLR	FUNCTION
0	1	Normal Display
0	0	Inverse Left and Right
1	1	Inverse Up and Down
1	0	Inverse Left and Right Inverse Up and Down

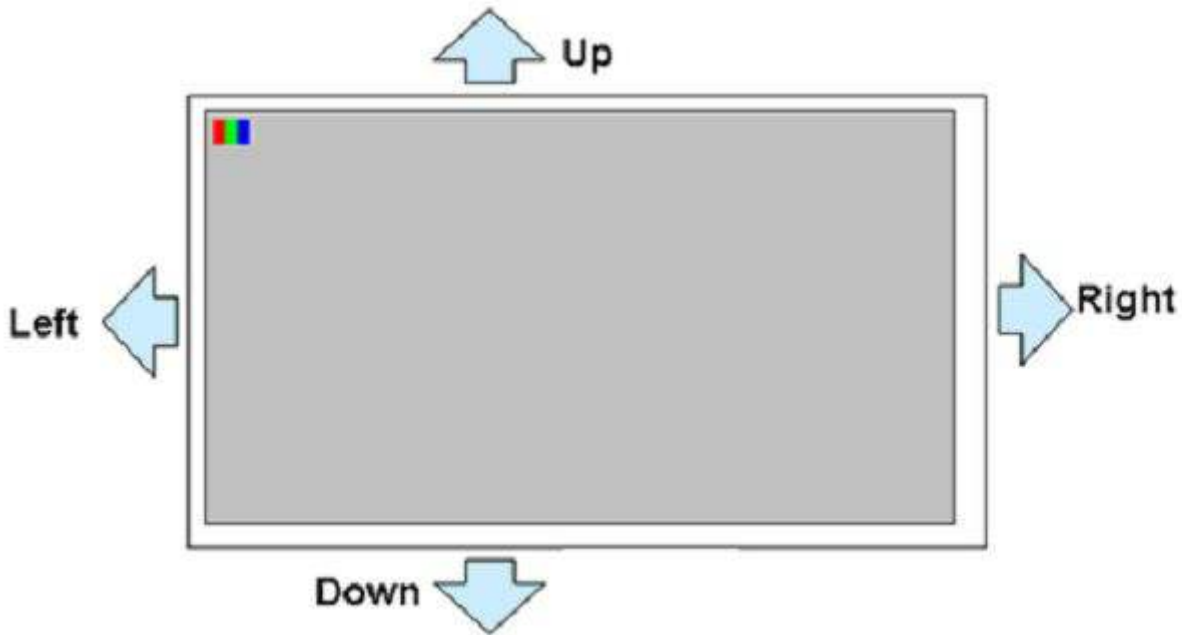

# 11. Caution

## 11.1 Handling of LCM

- . Be sure to ground the body when handling the LCM.**
- . Don't give external shock**
- . Don't apply excessive force on the surface.**
- . Liquid in LCD is hazardous substance. Must not lick and swallow.**  
**When the liquid is attach to your hand, skin, cloth etc. Wash it out thoroughly and immediately.**
- . Don't operate it above the absolute maximum rating.**
- . Don't disassemble the LCM**

## 11.2 Storage

- .Store in an ambient temperature of 5°C to 45°C, and in a relative humidity of 40% to 60%. Don't expose to sunlight or intensive ultraviolet rays**
- . Storage in a clean environment, free from dust, active gas, and solvent.**
- . Store in anti-static electricity container.**
- . Store without any physical load.**