



The Future of Analog IC Technology®

MP3021

1x, 1.5x, 2x Auto-Adjust Charge Pump White LED Backlight Driver

DESCRIPTION

The MP3021 is a WLED driver that can drive up to 4 backlight WLEDs at up to 30mA each. Backlight brightness is adjusted using a 5-bit register plus one bit for precise low brightness control.

The MP3021 employs a super efficient inductorless charge pump with 1x, 1.5x and 2x automatic mode control to achieve high efficiency power conversions.

Monolithic Power System's single wire MPC™ serial data link provides a simple and fast interface used to enable, disable and set current levels for each LED. In addition, soft-start limits the inrush current during startup and mode switching.

Each output is current limited, providing controlled brightness and short circuit protection. Thermal shutdown protection guards against excessive temperatures due to circuit loads and shorts.

The tiny 3mm x 3mm QFN 16-pin package and small external capacitors deliver the most compact white LED solution available.

FEATURES

- Backlight: up to 4 WLEDs at 30mA Each
- Single Wire Serial Bus (MPC™ Serial Data Link) Simple, Low Overhead Solution Fast Data Transfer Rate
- Good Current Matching at Low LED Current
- Thermal Shutdown Protection
- Under-Voltage Protection
- Available in a 3mm x 3mm 16-Pin QFN Package
- Low EMI Noise

APPLICATIONS

- Cellular Phones
- PDA Phones
- PDAs
- Other Small Portable Displays

"MPS" and "The Future of Analog IC Technology" are Registered Trademarks of Monolithic Power Systems, Inc.

"MPC" is a Trademark of Monolithic Power Systems, Inc.

TYPICAL APPLICATION

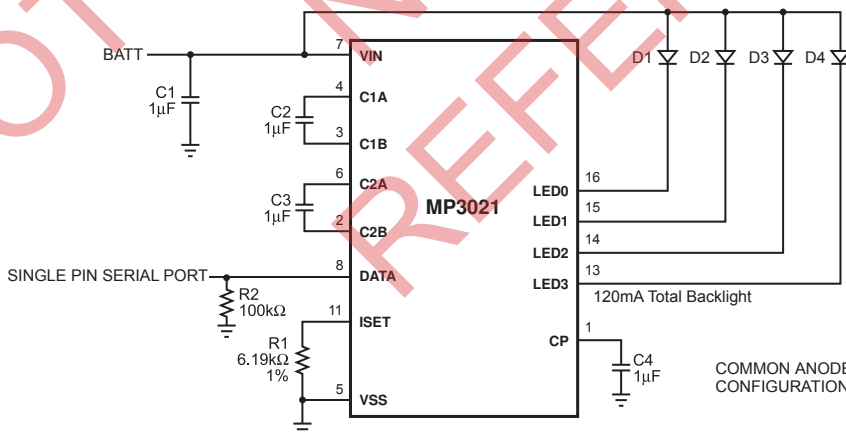

Efficiency vs Battery Voltage

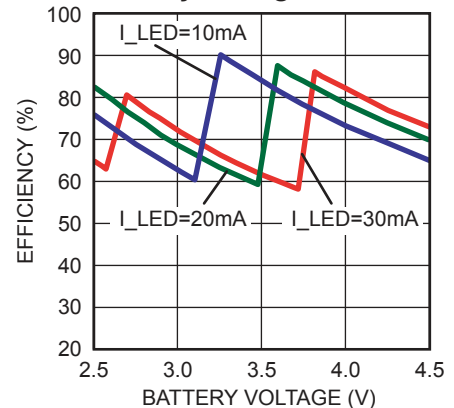

PACKAGE REFERENCE

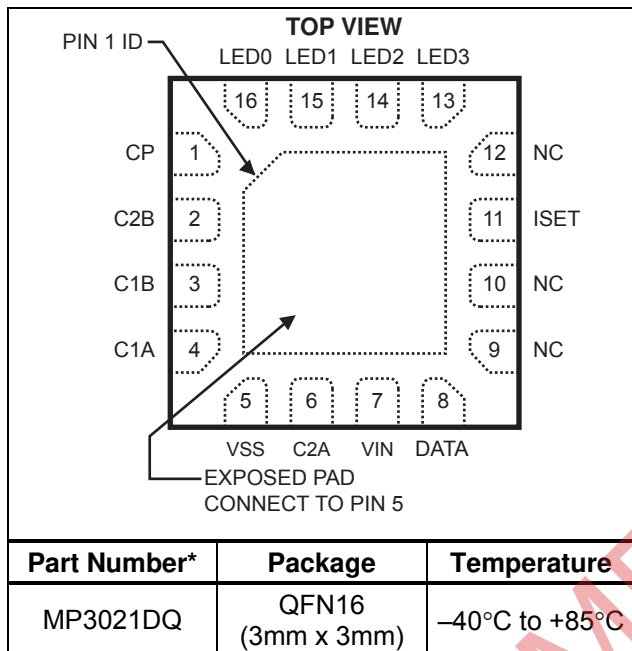

* For Tape & Reel, add suffix -Z (eg. MP3021DQ-Z)
 For RoHS compliant packaging, add suffix -LF (eg. MP3021DQ-LF-Z)

ABSOLUTE MAXIMUM RATINGS (1)

All Other Pins..... -0.3V to +6.5V
 Junction Temperature..... 150°C
 Lead Temperature 260°C
 Storage Temperature -65°C to +150°C
 Supply Voltage VIN 2.5V to 6V
 Operating Temperature -40°C to +85°C

Recommended Operating Conditions (2)

Supply Voltage VIN..... 2.7V to 5.5V
 Operating Temperature -40°C to +85°C

Thermal Resistance (3) θ_{JA} θ_{JC}
 QFN16 (3mm x 3mm)..... 60..... 12... °C/W

Notes:

- 1) Exceeding these ratings may damage the device.
- 2) The device is not guaranteed to function outside of its operating conditions.
- 3) Measured on approximately 1" square of 1 oz copper.

ELECTRICAL CHARACTERISTICS

VIN = 4.2V, TA = +25°C, unless otherwise noted.

Parameter	Symbol	Condition	Min	Typ	Max	Units
Input Supply Voltage	VIN		2.7		5.5	V
Supply Current	IIN	1X Mode; ILED ea = 20mA		83.6		mA
Supply Current Shutdown	IIN SHDN	VDATA = 0V		0.1	1.0	µA
Current Matching (4)	ILED MATCH	ILED = 20mA		1.5	3.0	%
DATA Voltage, High	VDATA (HIGH)		1.2			V
DATA Voltage, Low	VDATA (LOW)				0.4	V
DATA Pin Leakage	IDATA	VDATA = 5V	-1.0		+1.0	µA
Data Acceptance Pulse Width	TDA PW		1.5		3.5	µs
Data Stop Pulse Width	TDSPW		8			µs
Charge Pump Frequency	FCP	VIN = 3.3V	1.0	1.25	1.5	MHz
Voltage of ISET	VISET			1.25		V
Backlight LED Current for each LED	IBL	HC/LC = 0, R1=4.17kΩ		30		mA
		HC/LC = 1, R1=6.25kΩ		2	2.2	mA
		HC/LC = 0, R1=6.25kΩ		20	22	mA
Thermal Shutdown (5)	TS			150		°C

Note:

- 4) Current matching definition: (Max - Min)/(Max + Min)
- 5) Guaranteed by design.

PIN FUNCTIONS

Pin #	Name	Description
1	CP	Charge pump bypass for common anode version. Connect a 1 μ F bypass capacitor to GND.
2	C2B	Charge Pump Capacitor #2 Negative Node. Connect the negative side of the #2 charge pump capacitor to C2B.
3	C1B	Charge Pump Capacitor #1 Negative Node. Connect the negative side of the #1 charge pump capacitor to C1B.
4	C1A	Charge Pump Capacitor #1 Positive Node. Connect the positive side of the #1 charge pump capacitor to C1A. Typical applications require C1 to be 1 μ F.
5	VSS	Battery Power Ground. Connect the exposed pad to this pin.
6	C2A	Charge Pump Capacitor #2 Positive Node. Connect the positive side of the #2 charge pump capacitor to C2A. Typical applications require C2 to be 1 μ F.
7	VIN	Battery Power Input. Connect the 2.5V to 5.5V input source between BATT and GND. Bypass BATT to GND with a 1 μ F or greater capacitor.
8	DATA	Data Input and Single Pin Serial Port for Control of All Functions. See <i>Part Description</i> . An external pull-down resistor with a typical value of 100k Ω is required.
9, 10, 12	NC	No Connect.
11	ISET	Current Control Input. Connect a resistor between ISET and GND to set the backlight LED string current up to 30mA each
13	LED3	#4 LED Driver for Backlight. Connect a backlight LED between this pin and BATT, with the anode at BATT. If this pin is not used, leave the pin open.
14	LED2	#3 LED Driver for Backlight. Connect a backlight LED between this pin and BATT, with the anode at BATT. If this pin is not used, leave the pin open.
15	LED1	#2 LED Driver for Backlight. Connect a backlight LED between this pin and BATT, with the anode at BATT. If this pin is not used, leave the pin open.
16	LED0	#1 LED Driver for Backlight. Connect a backlight LED between this pin and BATT, with the anode at BATT. If this pin is not used, leave the pin open.

TYPICAL PERFORMANCE CHARACTERISTICS

$V_{BATT} = 4.2V$, $T_A = +25^{\circ}C$, unless otherwise noted.

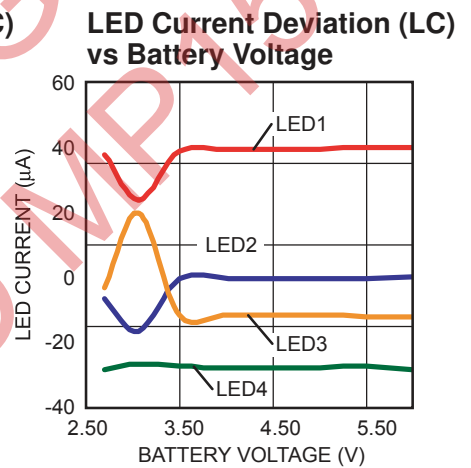
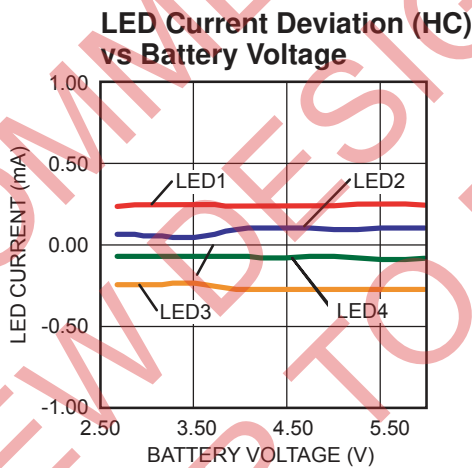
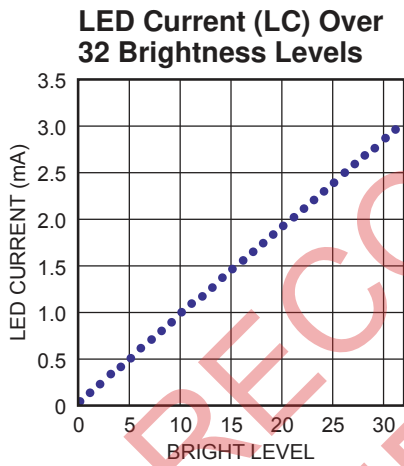
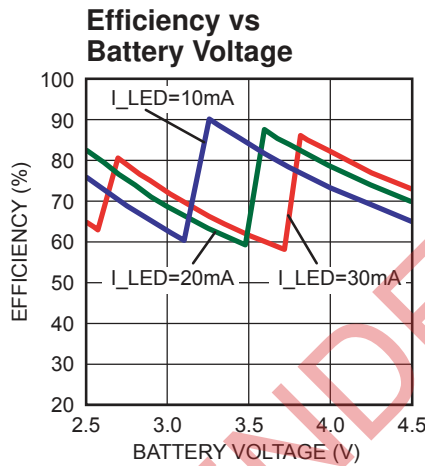
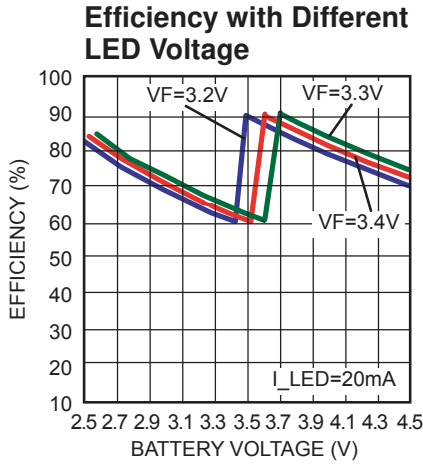

TYPICAL PERFORMANCE CHARACTERISTICS (continued)

$V_{BATT} = 4.2V$, $T_A = +25^\circ C$, unless otherwise noted.

Soft Start to 1X Mode

$V_{IN} = 4.2V$, 1X Mode, 4 LED Full Brightness

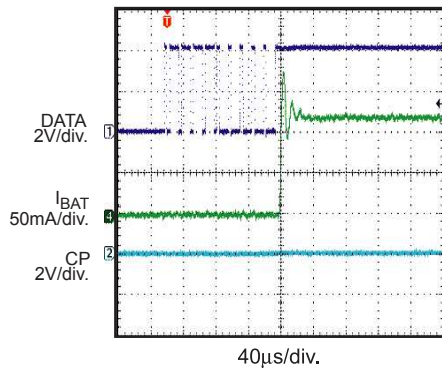

Soft Start to 1.5X Mode

$V_{IN} = 3.5V$, 1.5X Mode, 4 LED Full Brightness

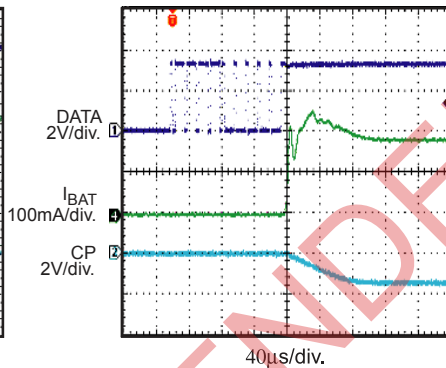

Soft Start to 2X Mode

$V_{IN} = 2.7V$, 2X Mode, 4 LED Full Brightness

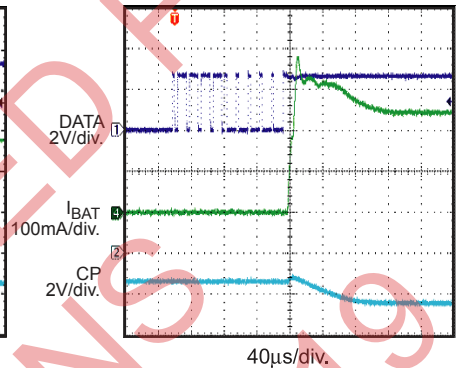

Mode Change From 1X to 1.5X

$V_{IN} = 3.3V$, 4 LED Full Brightness

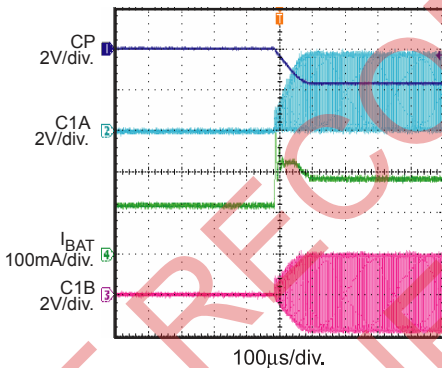

Mode Change From 1.5X to 2X

$V_{IN} = 2.7V$, 4 LED Full Brightness

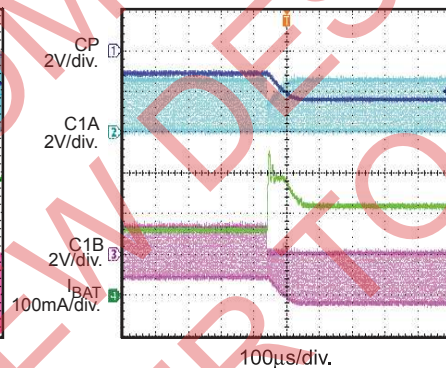

Charge Pump Waveform at 1.5X Mode

$V_{IN} = 3.06V$, 4 LED Full Brightness, 1.5X Mode

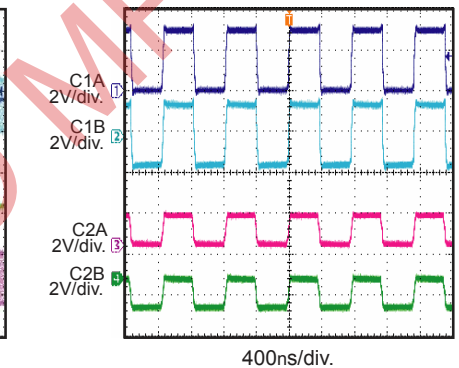

Charge Pump Waveform at 2X Mode

$V_{IN} = 3.06V$, 4 LED Full Brightness, 2X Mode

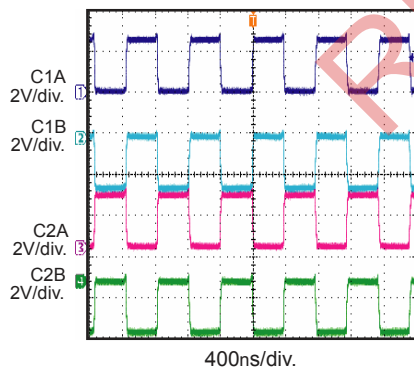

BLOCK DIAGRAM

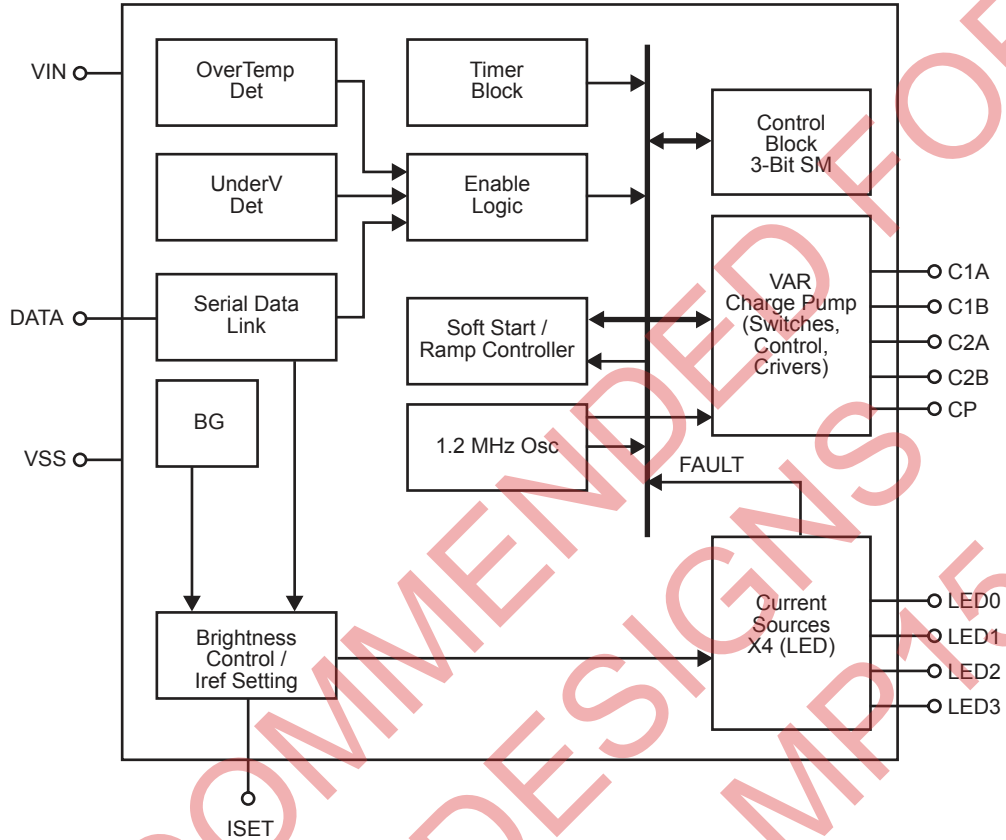

Figure 1—Functional Block Diagram

OPERATION

The MP3021 uses a charge pump architecture optimized to support white LED backlight driver needs. To maximize power efficiency, it automatically switches between 1X, 1.5X, and 2X modes. The device provides regulated current for up to four backlight LEDs.

The charge pump automatically responds to changing conditions such as supply voltage, forward diode voltage and mode selection in order to maintain LED current and maximize efficiency.

The single pin interface provides on/off control, individual WLED selection, and brightness control for the backlight. A 5-bit backlight brightness register provides 32 levels of current (brightness) control. ISET controls the maximum brightness of the backlights. Furthermore, the MP3021 is equipped with a low brightness backlight mode where the backlight current can be accurately set down to 100µA.

Soft-start and mode changes limit the inrush current in the MP3021. The MP3021 uses charge pump derating over a period of 200µs to limit inrush current. Before startup the part checks for a shorted charge pump and pre-charges its capacitors. This further prevents inrush and over-current situations.

Single Pin Serial Port Operation

The DATA pin acts as a single wire port for sending brightness data, LED selection and LED control to the MP3021. The MPC™ protocol is very flexible and easy to use and is based entirely on short and long pulses (see Table1). Short pulses having a width within the specified range are accepted as data. Polarity of the data matches the pulse polarity. Long pulses having a pulse width greater than the minimum specified serve two purposes in the communication. First, they are used to separate two similar data values. For example, back-to-back “1” data must be separated by a long low pulse otherwise a “0” would be seen between. Similarly, back-to-back “0”s must be separated by a long high. Second, long pulses are used to indicate end of communication by sending two back-to-back long pulses. Any number of bits up to a maximum of 11 can be entered during one communication, always starting with bit 0. The register value will not change until new input is received or the register is reset.

Table 1—MPC™ Pulse Detail

Parameter	Minimum	Maximum	Note
Tshort	1.5µs	3.5µs	Accepted Pulse
Tlong	8µs	NA	Ignored Pulse

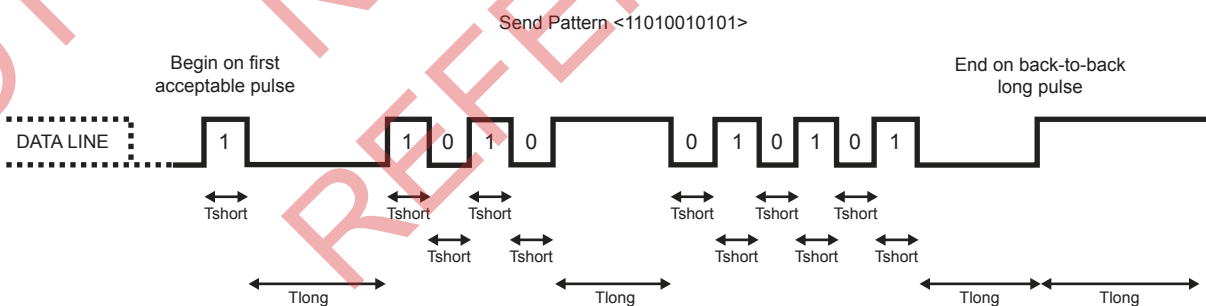

Figure 2—Protocol Waveforms

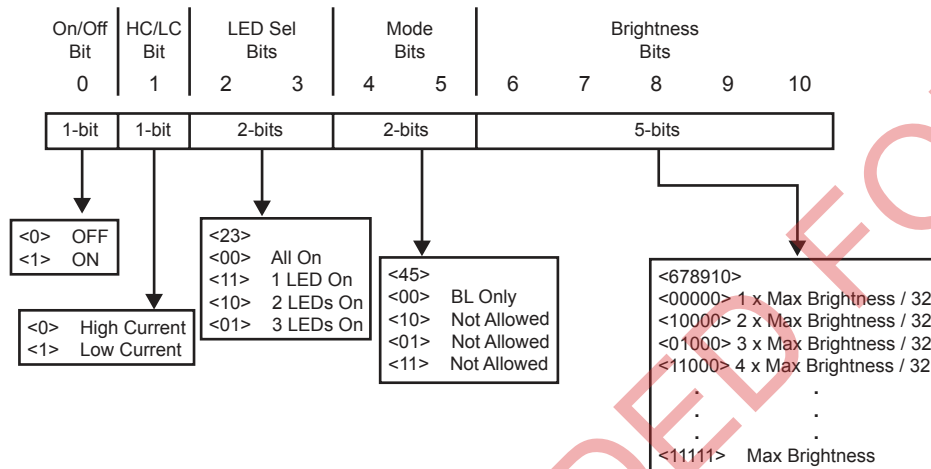

Figure 3—Control Register

Control Register Definition

The control register is as follows:

- Bit 0 is the enable bit and determines whether the part is active or in shutdown
- Bit 1 allows the part to be put into a low current mode
- Bits 2-3 control which backlight WLED pins are active
- Bits 4-5 control the mode [BL=backlight]. Always set B4B5 = <00>
- Bits 6-10 control the brightness. Step size and max brightness depend on R1 and Bit1. Bit 6 is the LSB.
- Default is all “0” and the register is reset only upon power up.

Shutdown

Setting the DATA-bit low [DATA:0] causes shutdown. During shutdown, the charge-pump output is switched to VSS through a weak path. The supply current will be less than 1µA in shutdown.

Soft-Start

During startup and mode switching, an internal soft-start prevents excessive input current thus preventing excessive loading of the battery or input power source.

Setting the Backlight LED Current

The full-scale backlight LED regulation current is set through the resistor R1 (refer to the typical application circuit on page 1). The voltage across R1 is fixed at 1.25V, and the internal current gain (I_{LED}/I_{R1}) is set at 100. Choose R1 for the desired full-scale LED current according to the equation:

$$R1 = 125k\Omega \times \frac{1mA}{I_{MAX}}$$

Where R1 is in kΩ, and I_{LED} is in mA. Suitable values for R1 are greater than 4.17kΩ.

The exact LED current between 0 and the max set by R1 is determined by the brightness code and the HC/LC bit.

The HC/LC bit allows for fine control at low current settings. The following table and graph exhibit the possible settings for a R1 of 4.17kΩ.

Table 2—Setting Backlight LED Current

5-Bit Brightness Code	I _{LED} (mA) HC/LC = 0	I _{LED} (mA) HC/LC = 1
0	0.94	0.09
1	1.88	0.19
2	2.81	0.28
3	3.75	0.38
4	4.69	0.47
5	5.63	0.56
6	6.56	0.66
7	7.50	0.75
8	8.44	0.84
9	9.38	0.94
10	10.31	1.03
11	11.25	1.13
12	12.19	1.22
13	13.13	1.31
14	14.06	1.41
15	15.00	1.50
16	15.94	1.59
17	16.88	1.69
18	17.81	1.78
19	18.75	1.88
20	19.69	1.97
21	20.63	2.06
22	21.56	2.16
23	22.50	2.25
24	23.44	2.34
25	24.38	2.44
26	25.31	2.53
27	26.25	2.63
28	27.19	2.72
29	28.13	2.81
30	29.06	2.91
31	30.00	3.00

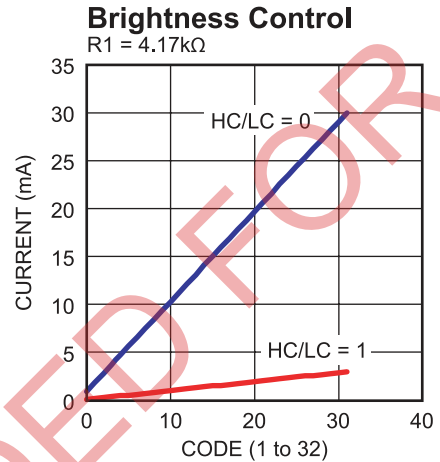

Figure 4—Brightness Control

CP Pin

Do not drive or force CP as it may be shorted to ground or pumped down by the controller in the MP3021 at any time. Excessive capacitance on the CP node can cause the internal controller to time out before the charge pump can be ready. Missing the timeouts will cause excessive pumping and a loss of efficiency. The MP3021 requires C1 and C2 be of the same value and type.

PACKAGE INFORMATION

QFN16 (3mm x 3mm)

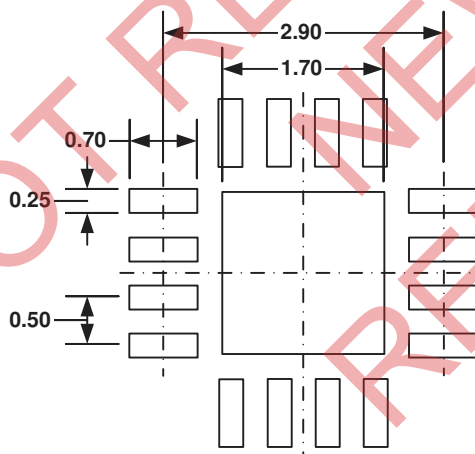
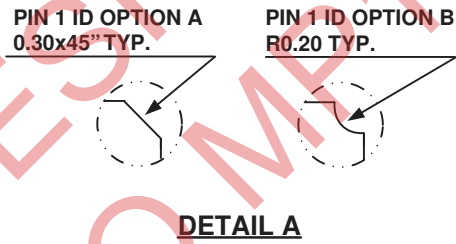
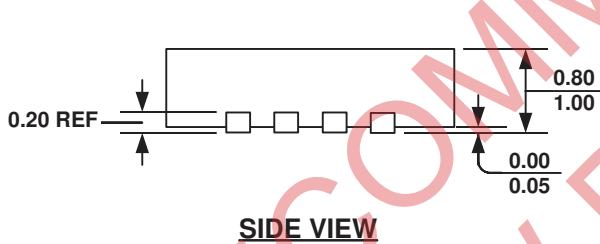
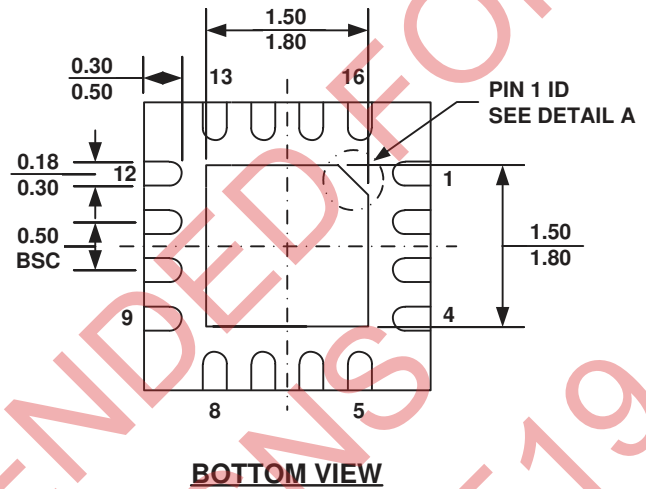
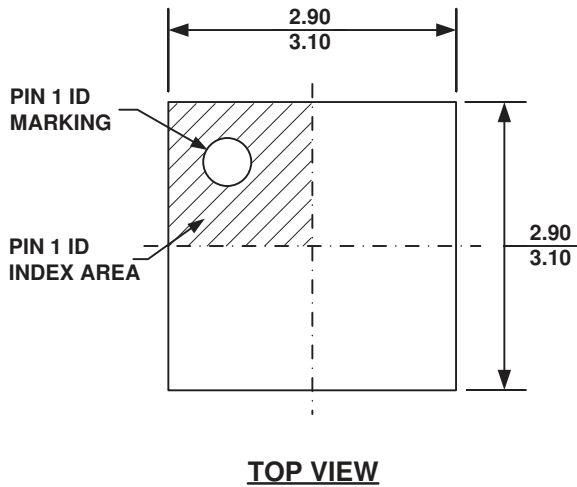

NOTE:

- 1) ALL DIMENSIONS ARE IN MILLIMETERS.
- 2) EXPOSED PADDLE SIZE DOES NOT INCLUDE MOLD FLASH.
- 3) LEAD COPLANARITY SHALL BE 0.10 MILLIMETER MAX.
- 4) DRAWING CONFORMS TO JEDEC MO-220, VARIATION VEED-4.
- 5) DRAWING IS NOT TO SCALE.

NOTICE: The information in this document is subject to change without notice. Users should warrant and guarantee that third party Intellectual Property rights are not infringed upon when integrating MPS products into any application. MPS will not assume any legal responsibility for any said applications.