

THIS COPY IS PROVIDED ON A RESTRICTED BASIS AND IS NOT TO BE USED IN ANY WAY DETRIMENTAL TO THE INTERESTS OF PANDUIT CORP.

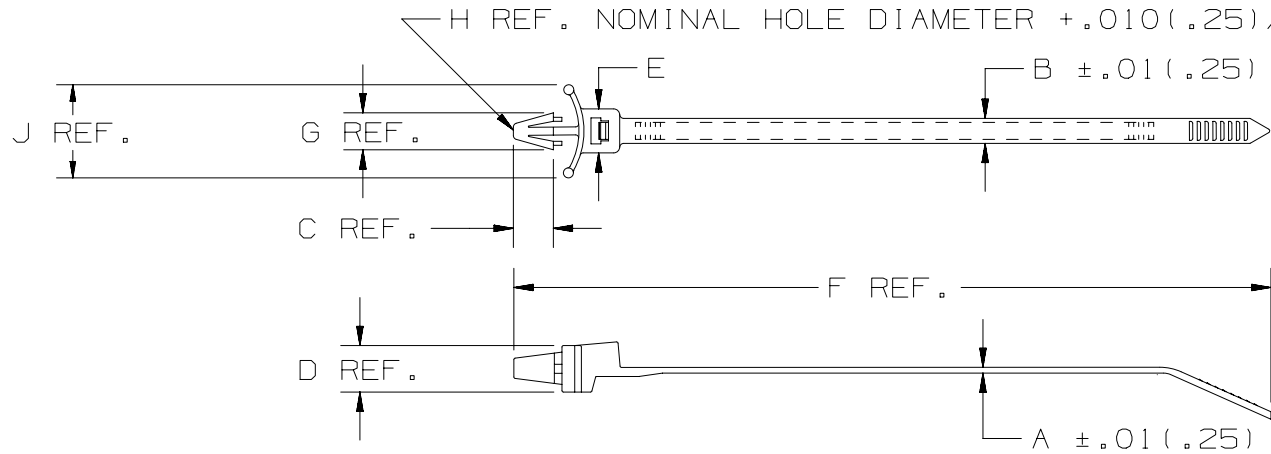

| PANDUIT PART NO. | BUNDLE DIAMETER | | A in (mm) | B in (mm) | REF. C in (mm) | REF. D in (mm) | E in (mm) | REF. F in (mm) | REF. G in (mm) | REF. H in (mm) | REF. J in (mm) | MAX PANEL THICKNESS in (mm) | MIN. LOOP TENSILE lbs (N) | CROSS SECTION | WEIGHT 100 pcs. lbs (g) |
|------------------|-----------------|-----------------|---------------|---------------|-------------------|-------------------|---------------|-------------------|-------------------|-------------------|-------------------|--------------------------------|------------------------------|---------------|-------------------------------|
| | MIN. in (mm) | MAX. in (mm) | | | | | | | | | | | | | |
| PLWP1M | .06 (1.5) | .87 (22.1) | .044 (1.1) | .098 (2.5) | .230 (5.8) | .220 (5.6) | .180 (4.6) | 4.3 (109) | .240 (6.1) | .187 (4.7) | .53 (13.5) | .093 (2.4) | 18 (80) | MINIATURE | .11 (50) |
| PLWP1.5I | .06 (1.5) | 1.25 (31.8) | .045 (1.2) | .135 (3.4) | .230 (5.8) | .280 (7.1) | .240 (6.1) | 6.0 (152) | .240 (6.1) | .187 (4.7) | .450 (11.4) | .093 (2.4) | 40 (178) | INTERMEDIATE | .17 (77) |
| PLWP1S | .06 (1.5) | 1.00 (25.4) | .052 (1.3) | .190 (4.8) | .300 (7.6) | .370 (9.4) | .316 (8.0) | 5.2 (132) | .330 (8.4) | .250 (6.4) | .74 (18.8) | .105 (2.7) | 50 (222) | STANDARD | .29 (132) |
| PLWP1.5S | .06 (1.5) | 1.50 (38.1) | .052 (1.3) | .190 (4.8) | .300 (7.6) | .370 (9.4) | .316 (8.0) | 6.8 (173) | .330 (8.4) | .250 (6.4) | .74 (18.8) | .105 (2.7) | 50 (222) | STANDARD | .34 (154) |
| PLWP2S | .06 (1.5) | 1.75 (44.5) | .052 (1.3) | .190 (4.8) | .300 (7.6) | .370 (9.4) | .316 (8.0) | 7.8 (198) | .330 (8.4) | .250 (6.4) | .74 (18.8) | .105 (2.7) | 50 (222) | STANDARD | .37 (168) |

NOTES:

1. RECOGNIZED UNDER THE COMPONENT PROGRAM OF UNDERWRITERS LABORATORIES INC.

DIMENSIONS IN PARENTHESES ARE IN METRIC UNITS

| REV | DATE | BY | CHK | APR | DESCRIPTION | ECN | TITLE | MATERIAL: | DRAWING NUMBER: | SIZE |
|-----|----------|-----|------|------|---|-------------|--|--------------------|-----------------|------------|
| | | | | | | | LOCKING WING PUSH MOUNT TIE - PLWP SERIES | NYLON 6.6 | SS-17564 | A |
| | | | | | | | CUSTOMER DRAWING | | | |
| | | | | | | | ITEM REVISION NAME | | | |
| | | | | | | | W10001BI/01 | | | |
| | | | | | | | DATASET FILE NAME | | | |
| | | | | | | | W10001BI/01-SS_17564_REV14 | | | |
| | | | | | | | UNLESS OTHERWISE SPECIFIED, DIMENSIONAL TOLERANCES ARE: IN [mm] | | | |
| | | | | | | | .x ± .1 (2.5) | .xxx ± .020 (.51) | | |
| | | | | | | | .xx ± .02 (.5) | ANGLES ± - - - - - | | |
| | | | | | | | THIRD ANGLE PROJECTION | | | |
| | | | | | | | UPDATED TITLE BORDER. | | | |
| 14 | 11/25/13 | BWG | JADE | JADE | REVISED REF. NOTES. SEE ECN FOR COMPLETE DETAILS. | SS-17564/14 | | | | |
| | | | | | | | DRAWN BY | DATE | CHK | SCALE |
| | | | | | | | C.HARVELL | 05/26/92 | HVP | NONE |
| | | | | | | | | | | SHT 1 OF 1 |

D10100DA/16