

## Notes:

1. No tracks or vias in the shaded "KEEP OUT" AREA.
2. No other track or signal within 0.020" of any contact pad.
3. Do not allow solder paste on the contact pads. It is essential to eliminate any hole in the solder paste-mask (solder stencil) layer. If this is not possible make the contact pads thru-hole with finished hole size of 0.008" or less.
4. To avoid ordering confusion, please specify DNL in your BOM.

## FOOTPRINT FOR TC2050-IDC-NL PLUG OF NAILS<sup>(TM)</sup> CABLE

REV	TC2050-IDC-NL-FP	12/2/10	MS
-----	------------------	---------	----

5. The TC2050-CLIP board can attach to the three alignment pins from underneath the PCB to temporarily retain the cable in place.

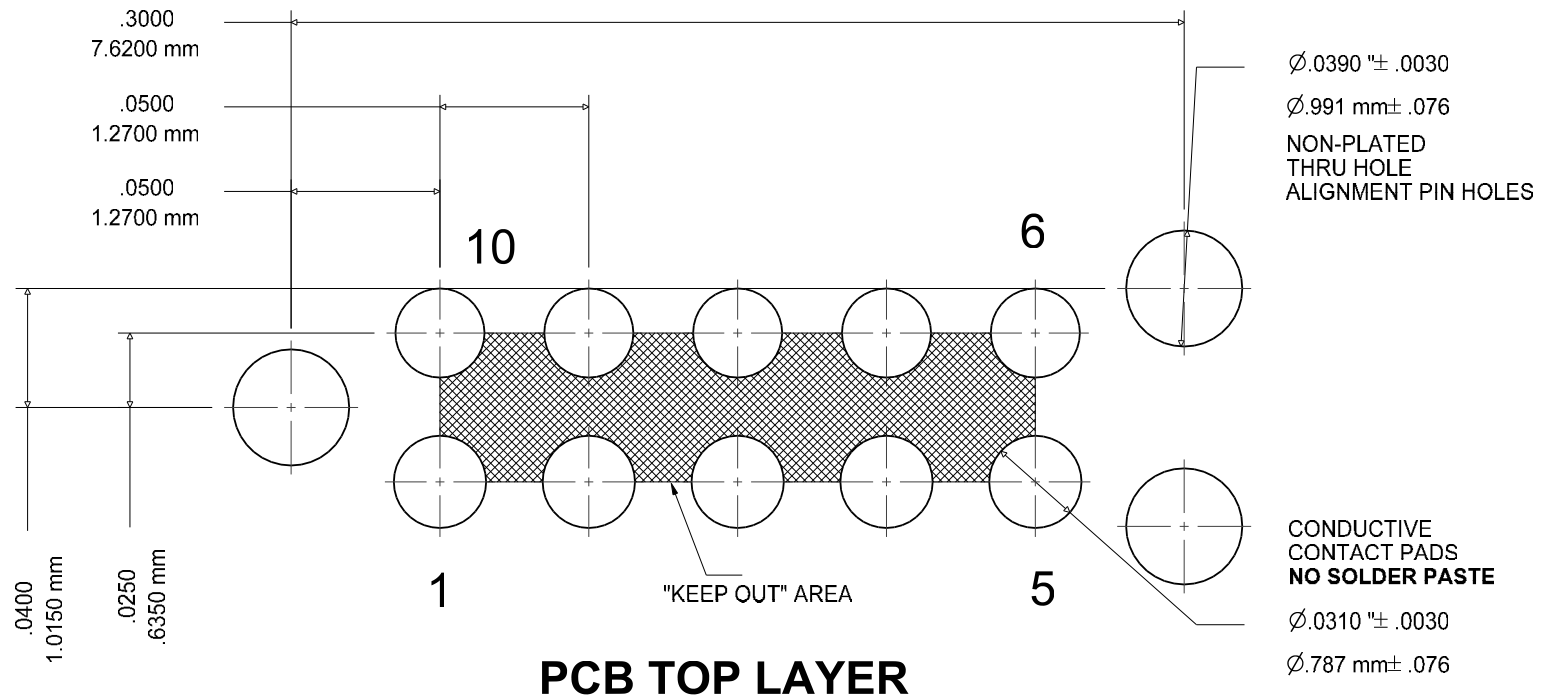

SIZE <b>A</b>	FSCM NO.	DWG NO. <b>FOOTPRINT FOR TC2050-IDC-NLFP</b>	REV <b>A</b>
SCALE 10:1	www.TAG-CONNECT.com	SHEET 1 of 3	

NOTE:  
**Dimensions subject to change**

# TC2050-IDC-NL PLUG-OFF-NAILS™ CABLE

ZONE	REV	TC2050-IDC-NL	12/2/10	MS
------	-----	---------------	---------	----

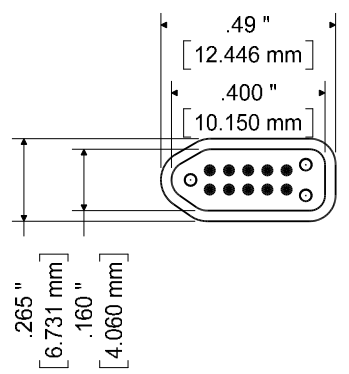
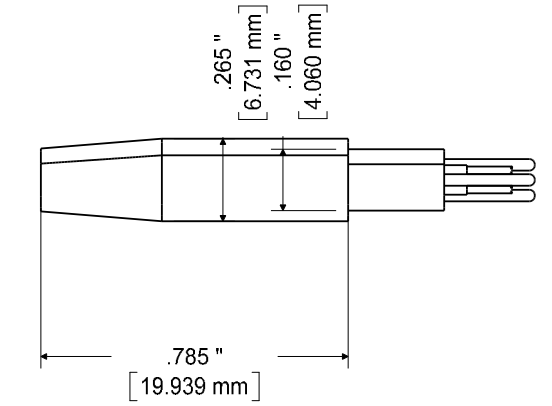
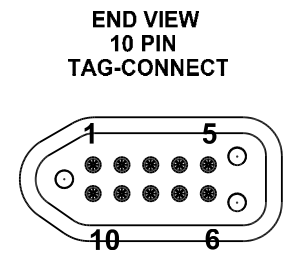
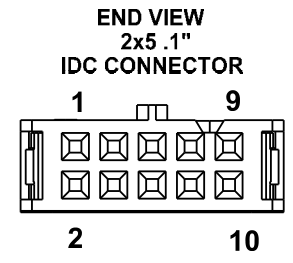
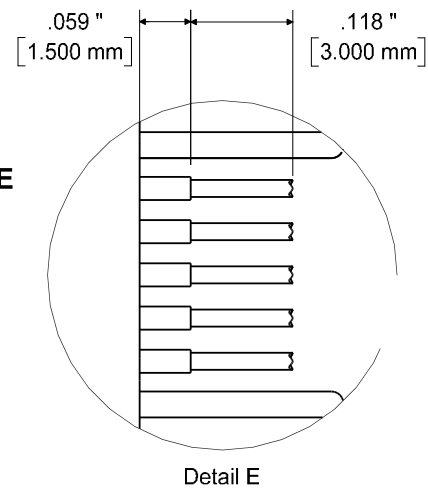
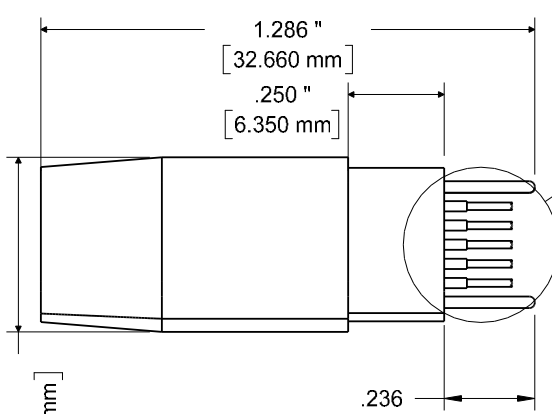
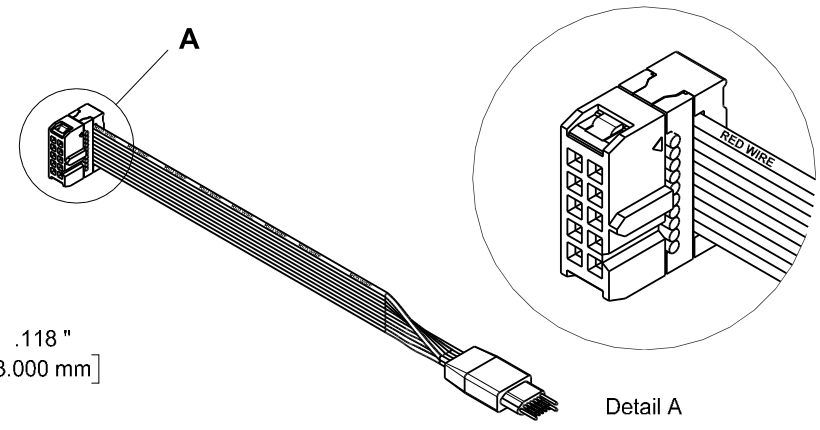
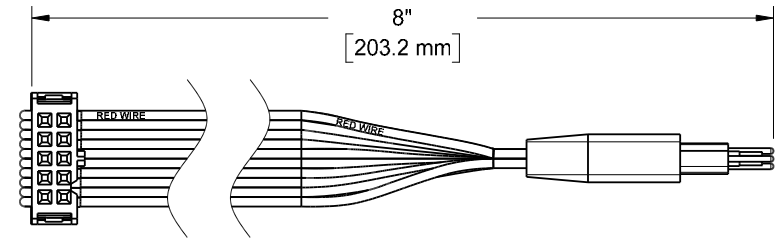

SIZE <b>A</b>	FSCM NO.	DWG NO. <b>TC2050-IDC-NL</b>	REV <b>A</b>
SCALE	<a href="http://www.TAG-CONNECT.com">www.TAG-CONNECT.com</a>		SHEET 2 OF 3

# Layout Problems to Avoid

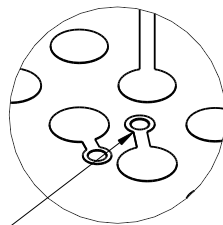
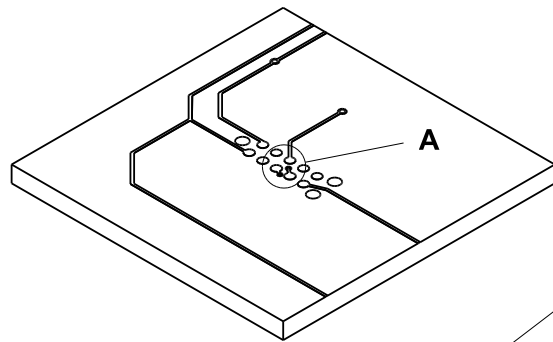

Detail A

Vias between contact pads

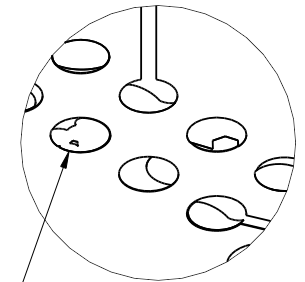
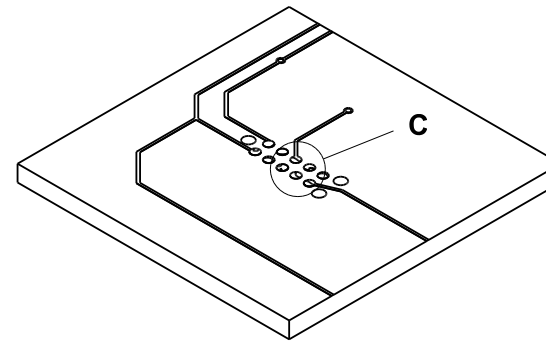

Detail C

Do not deposit solder paste on contact pads. View Solder Paste Mask (Solder Stencil) layer in pad-stack and eliminate any hole.

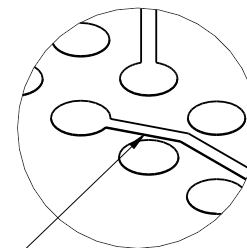
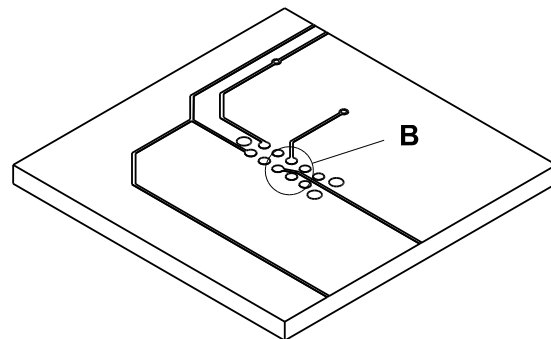

Detail B

Traces less than .02" away from contact pad or in "KEEP OUT" area