

Tous droits strictement reserves. Reproduction ou communication a des tiers interdite sous quelque forme que ce soit sans autorisation ecrite du proprietaire. Propriete de c FCI. Droits de reproduction FCI.

All rights strictly reserved. Reproduction or issue to third parties in any form whatever is not permitted without written authority from the proprietor. Property of FCI. Copyright FCI.

PRODUCT NO.
SEE SHT. 2

SIDE VIEW OF ASS'Y.
AFTER TERMINATION

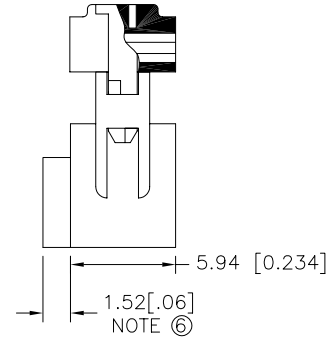
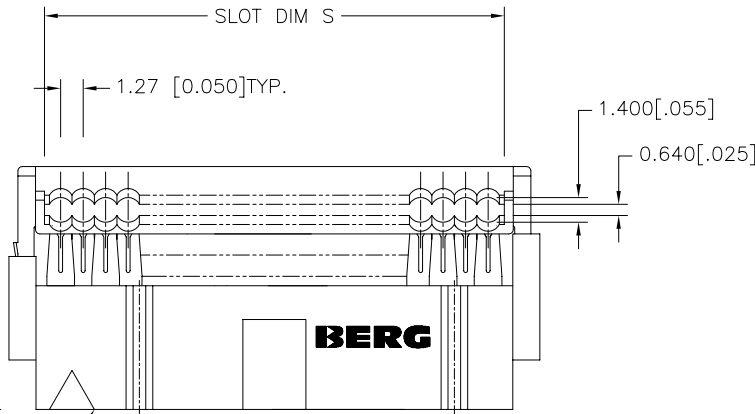
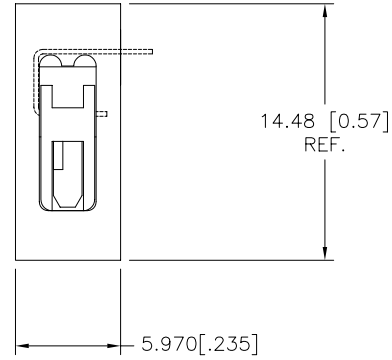
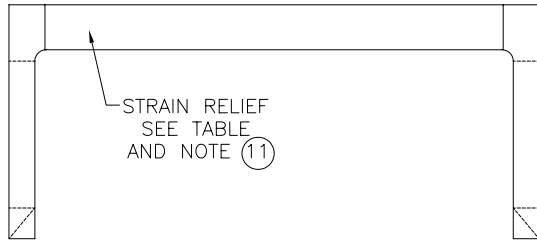

TRIANGLE INDICATES POSITION ONE

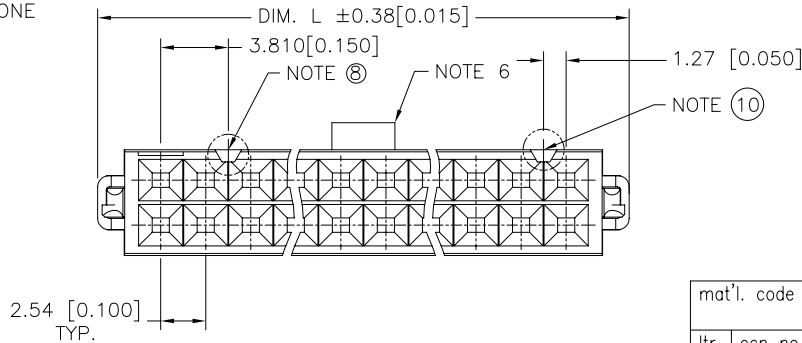

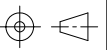
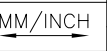
mat'l. code				tolerances unless otherwise specified			CUSTOMER COPY	 www.fciconnect.com	
ltr	ecn no	dr	date	linear	.xx ±.01/.x±.3		projection	title	
E	TRANSFER	RHA	11/23/81		.xxx ±.005/.xx±.13				QUICKIE L.P ASS'Y STRAIN RELIEF
F	RELEASED	BLI	1/82	angles	.xxxx ±.0020/.xxx±.051				product family QUICKIE
G	5003	BLI	8/83		0° ±2°			MM/INCH	code
H	N10816	CN	10/88	dr	R.G. Draggoo	10/2/98	scale		size
J	V81770	RGD	10/2/98	enr	M. SYMK	10/2/98		1:1	dwg no
K	V90596	RGD	3/2/99	chr	M. SYMK	10/2/98	A		66564
L	N05-0060	MHT	03/04/05	appd	M. SYMK	10/2/98		sheet	
sheet index		revision sheet		L	L		cage code		
		1 2					22526		

Tous droits strictement reserves. Reproduction ou communication a des tiers interdite sous quelque forme que ce soit sans autorisation ecrite du proprietaire. Propriete de c FCI. Droits de reproduction FCI.

FCI

All rights strictly reserved. Reproduction or issue to third parties in any form whatever is not permitted without written authority from the proprietor. Property of FCI. Copyright FCI.

1 | 2

3 |

4

PRODUCT NO.	SIZE	DIM "L"	DIM "S"	LEAD FREE OPTION
66564-X06	2x3	12.19/[.480]	8.128/[.320]	NOTE 13, 14
66564-X08	2x4	14.73/[.580]	10.668/[.420]	
66564-X10	2x5	17.27/[.680]	13.210/[.520]	
-X14	2x7	22.35/[.880]	18.290/[.720]	
-X16	2x8	24.89/[.980]	20.830/[.820]	
-X20	2x10	29.97/[1.180]	25.910/[1.020]	
-X26	2x13	37.59/[1.480]	33.530/[1.320]	
-X34	2x17	47.75/[1.880]	43.690/[1.720]	
-X40	2x20	55.37/[2.180]	51.310/[2.020]	
-X50	2x25	68.07/[2.680]	64.010/[2.520]	
66564-X60	2x30	80.77/[3.180]	76.710/[3.020]	

X	COVER		POL. KEY	STR REL.	
	STYLE	ENTRY			
5	THRU	DUAL	NO	NO	SEE NOTE 12
6	THRU	DUAL	NO	NO	SEE NOTE 11
7	THRU	DUAL	YES	NO	SEE NOTE 11
8	THRU	DUAL	YES	YES	
9	THRU	DUAL	NO	YES	

NOTES:

1. TERMINAL MAT'L: PHOS BRONZE, FULL HARD, ALLOY UNS-C51000.
2. TERMINAL PLATING: 0.7u/30u" GOLD IN CONTACT AREA OVER 1.27u 50u" NICKEL. REMAINDER OF TERM. 1.27u 50u" NICKEL.
3. MOLDING MAT'L: BASE AND COVER- GLASS FILLED POLYESTER, FLAME RETARDANT PER UL 94V-0: COLOR- BLUE
4. CONNECTOR ASS'YS PACKAGED IN TUBES THEN BOXED IN LOTS OF 100.
5. THE FIRST TWO CAVITY POSITIONS AND THE LAST TWO ARE IDENTIFIED BY NUMBER
6. POLARIZING FEATURE OPTIONAL, SEE TABLE.
7. MOLDING MAT'L: STRAIN RELIEF- UNFILLED THERMOPLASTIC, FLAME-RETARDANT: UL 94 V-0: COLOR-BLUE.
8. THE POLARIZING FEATURE ON THIS END IS NON EXISTENT ON 6,8,10, AND 14 POS. CONNECTORS.
9. 10 POSITION CONNECTOR NOT AVAILABLE WITH BOTH POL. SLOTS AND KEY.
10. THE POLARIZING FEATURE ON THIS END IS NON EXISTENT ON 6 AND 8 POS. CONNECTORS.
11. THE PRODUCT NUMBERS 66564-6XX AND 66564-7XX ONLY COUNT FOR 2x3 AND 2x4 POS. CONNECTORS FOR ALL OTHER VERSIONS WITHOUT STRAIN RELIEF (2x5---2x30) REFER TO P/N 66900
12. PRODUCT NUMBER 66564-506 ONLY WITHOUT BERG LOGO.
13. ADD "LF" SUFFIX AT THE END OF PART NUMBER FOR LEAD FREE OPTION.
14. THESE PRODUCTS MEET EUROPEAN UNION DIRECTIVES AND OTHER COUNTRY REGULATION AS DESCRIBED IN GS-22-008.
15. THE PRODUCT IS NOT INTENDED TO BE EXPOSED TO A MANUFACTURING SOLDER PROCESS.

COVER ORIENTATION

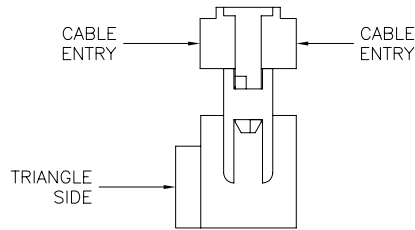

DUAL ENTRY

mat'l. code				tolerances unless otherwise specified			CUSTOMER COPY		FCI		
-									www.fciconnect.com		
ltr	ecn no	dr	date	linear	.xx ±.01/.x±.3		projection	title			
L					.xxx ±.005/.xx±.13				QUICKIE L.P. ASS'Y		
					.xxx ±.0020/.xxx±.051				STRAIN RELIEF		
				angles	0° ±2'			product family		code	
				dr	R.G Draggo	10/2/98		QUICKIE		-	
				enr	M. SYMK	10/2/98		size	dwg no	sheet	
				chr	M. SYMK	10/2/98		scale		2 of	
				appd	M. SYMK	10/2/98	1:1	A	66564		
sheet index	revision sheet										

1 | 2

3 |

4

ACAD

PDM: Rev:L

STATUS: Released

Printed: Feb 09, 2010

cage code
22526