

## Evaluation Board for the **AD5233** Digital Potentiometer

### FEATURES

Full featured evaluation board for the **AD5233**  
Several test circuits  
Various ac/dc input signals  
PC control via a separately purchased system demonstration platform (SDP-B)  
PC control software  
12 extra bytes in EEMEM for user-defined information  
Resistor tolerance error stored in EEMEM

### PACKAGE CONTENTS

**EVAL-AD5233SDZ** board

CD that includes

- Self-installing software that allows users to control the board and exercise all functions of the device
- Electronic version of the **AD5233** data sheet
- Electronic version of the **UG-350** user guide

### GENERAL DESCRIPTION

This user guide describes the evaluation board for evaluating the **AD5233**—a quad-channel, 64-position, nonvolatile memory digital potentiometer. With versatile programmability, the **AD5233** allows multiple modes of operation, including read/write access in the RDAC and EEMEM registers, increment/decrement of resistance, resistance changes in  $\pm 6$  dB scales, wiper setting read-back, and extra EEMEM for storing user-defined information, such as memory data for other components or a lookup table.

The **AD5233** supports dual-supply  $\pm 2.5$  V to  $\pm 2.75$  V operation and single-supply 2.7 V to 5.5 V operation, making the device suited for battery-powered applications and many other applications. In addition, the **AD5233** uses a versatile SPI-compatible serial interface, allowing speeds of up to 50 MHz.

The **EVAL-AD5233SDZ** can operate in single-supply and dual-supply mode and incorporates an internal power supply from the USB.

Complete specifications for the **AD5233** part can be found in the **AD5233** data sheet, which is available from Analog Devices, Inc., and should be consulted in conjunction with this user guide when using the evaluation board.

### DIGITAL PICTURE OF EVALUATION BOARD WITH SYSTEM DEMONSTRATION PLATFORM

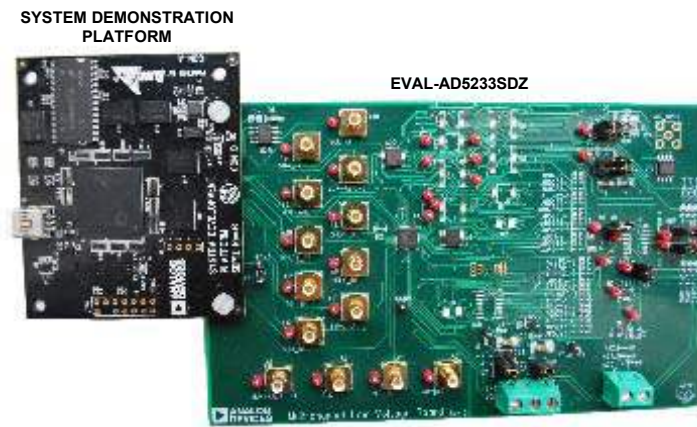

Figure 1.

**TABLE OF CONTENTS**

Features .....	1	Test Circuits .....	4
Package Contents.....	1	Evaluation Board Software.....	6
General Description .....	1	Installing the Software .....	6
Digital Picture of Evaluation Board with System Demonstration Platform .....	1	Running the Software .....	6
Revision History .....	2	Software Operation .....	7
Evaluation Board Hardware .....	3	Evaluation Board Schematics and Artwork .....	8
Power Supplies .....	3	Ordering Information.....	14
Link Options .....	3	Bill of Materials.....	14

**REVISION HISTORY**

12/11—Revision 0: Initial Version

## EVALUATION BOARD HARDWARE

### POWER SUPPLIES

The [EVAL-AD5233SDZ](#) supports the use of single and dual power supplies.

In single-supply mode, the evaluation board can be powered either from the SDP port or externally by the J1-1, J1-2, and J1-3 connectors, as described in Table 1.

If dual-supply mode is required, the J1-1, J1-2, and J1-3 connectors must provide the external power supply, as described in Table 1.

All supplies are decoupled to ground using 10  $\mu$ F tantalum and 0.1  $\mu$ F ceramic capacitors.

**Table 1. Maximum and Minimum Voltages of the Connectors**

Connector No.	Label	Voltage
J1-1	EXT VDD	Analog positive power supply, $V_{DD}$ . For single-supply operation, it is 2.7 V to 5.5 V. For dual-supply operation, it is 2.5 V to 2.75 V.
J1-2	GND	Analog ground.
J1-3	EXT VSS	Analog negative power supply, $V_{SS}$ . For single-supply operation, it is 0V. For dual-supply operation, it is -2.5 V to -2.75 V.

**Table 3. Link Functions**

Link No.	Power Supply	Options
A25	$V_{DD}$	This link selects one of the following as the positive power supply: 5 V (from SDP-B). 3.3 V (from SDP-B). EXT VDD (external supply from the J1-1 connector).
A24	$V_{SS}$	This link selects one of the following as the negative power supply: GND (analog ground). EXT VSS (external supply from the J1-3 connector).

### LINK OPTIONS

Several link and switch options are incorporated in the evaluation board and should be set up before using the board. Table 2 describes the positions of the links to control the evaluation board by a PC, via the SDP-B board, using the [EVAL-AD5233SDZ](#) in single-supply mode. The functions of these link and switch options are described in detail in Table 3 through Table 6.

**Table 2. Link Options Setup for SDP-B Control (Default)**

Link No.	Option
A25	3.3 V
A24	GND

**TEST CIRCUITS**

The EVAL-AD5233SDZ incorporates several test circuits to evaluate the AD5233 performance.

**DAC**

RDAC1 can be operated as a digital-to-analog converter (DAC), as shown in Figure 2.

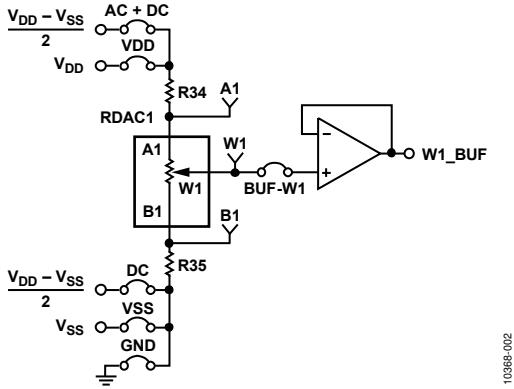

Figure 2. DAC

Table 4 shows the options available for the voltage references.

**Table 4. DAC Voltage References**

Terminal	Link	Options	Description
A1	A20	AC + DC	Connects Terminal A1 to $(V_{DD} - V_{SS})/2$
		VDD	Connects Terminal A1 to $V_{DD}$
W1	BUF-W1		Connects Terminal W1 to an output buffer
B1	A21	DC	Connects Terminal B1 to $(V_{DD} - V_{SS})/2$
		VSS	Connects Terminal B1 to $V_{SS}$
		GND	Connects Terminal B1 to analog ground

The output voltage is defined in Equation 1.

$$V_{OUT} = (V_{A1} - V_{B1}) \times \frac{RDAC1}{64} \quad (1)$$

where:

$RDAC1$  is the code loaded in the RDAC1 register.

$V_{A1}$  is the voltage applied to the A1 terminal (A20 link).

$V_{B1}$  is the voltage applied to the B1 terminal (A21 link).

Using the R34 and R35 external resistors, the user can reduce the voltage of the voltage references. In this case, use the A1 and B1 test points to measure the voltage applied to the A1 and B1 terminals and recalculate  $V_{A1}$  and  $V_{B1}$  in Equation 1.

**AC Signal Attenuation**

RDAC1 can be used to attenuate an ac signal, which must be provided externally using the AC\_INPUT connector, as shown in Figure 3.

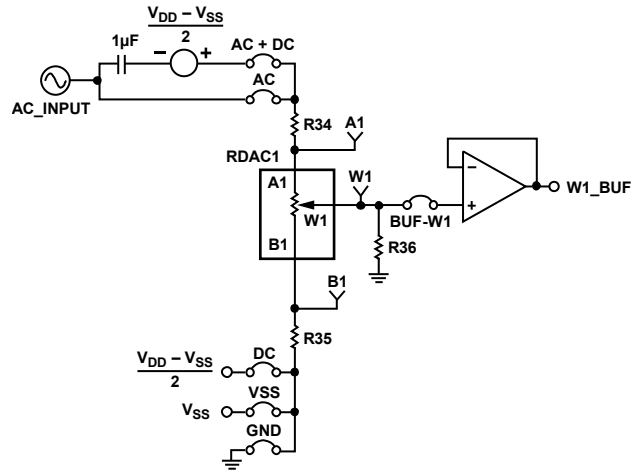

Figure 3. AC Signal Attenuator

Depending on the voltage supply rails and the dc offset voltage of the ac signal, various configurations can be used, as described in Table 5.

**Table 5. AC Signal Attenuation Link Options**

Voltage Supply	Maximum AC Signal Amplitude	Link	Options	Conditions
Single	$V_{DD}$	A20	AC + DC	No dc offset voltage. AC signal is outside the voltage supply rails due to the dc offset voltage. DC offset voltage $\neq V_{DD}/2$ . <sup>1</sup> All other conditions.
			AC	All other conditions.
		A21	DC	Use in conjunction with AC + DC link. All other conditions.
			GND	All other conditions.
Dual	$V_{DD}/V_{SS}$	A20	AC + DC	AC signal is outside the voltage supply rails due to the dc offset voltage. DC offset voltage $\neq 0$ V. <sup>1</sup> All other conditions.
			AC	All other conditions.
		A21	GND	Use in conjunction with AC + DC link. All other conditions.
			VSS	All other conditions.

<sup>1</sup> Recommended to ensure optimal total harmonic distortion (THD) performance.

The signal attenuation is defined in Equation 2.

$$Attenuation (dB) = 20 \times \log \left( \frac{R_{WB1} + R_W}{R_{END-TO-END}} \right) \quad (2)$$

where:

$R_{WB1}$  is the resistor between the W1 and B1 terminals.

$R_W$  is the wiper resistance.

$R_{END-TO-END}$  is the end-to-end resistance value.

In addition, R36 can be used to achieve a pseudologarithmic attenuation. To do so, adjust the R36 resistor until a desirable transfer function is found.

**Signal Amplifier**

RDAC2 can be operated as an inverting or noninverting signal amplifier supporting linear or pseudologarithmic gains. Table 6 shows the available configurations.

**Table 6. Amplifier Selection Link Options**

Amplifier	Gain	Link	Label <sup>1</sup>
Noninverting	Linear	A27	LINEAR
		A29	NON-INVERTING
		A30	NON-INVERTING
	Pseudologarithmic	A27	PSEUDOLOG
		A29	NON-INVERTING
		A30	NON-INVERTING
Inverting	Linear	A27	LINEAR
		A29	INVERTING
		A30	INVERTING
	Pseudologarithmic	A27	PSEUDOLOG
		A29	INVERTING
		A30	INVERTING

<sup>1</sup> See Figure 17.

The noninverting amplifier with linear gain is shown in Figure 4, and the gain is defined in Equation 3.

$$G = 1 + \frac{R_{WB2}}{R38} \tag{3}$$

where  $R_{WB2}$  is the resistor between the W2 and B2 terminals.

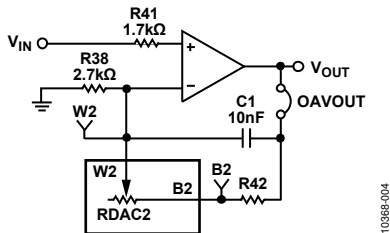

Figure 4. Linear Noninverting Amplifier

The noninverting amplifier with pseudologarithmic gain is shown in Figure 5, and the gain is defined in Equation 4.

$$G = 1 + \frac{R_{WB2}}{R_{AW2}} \tag{4}$$

where:

$R_{WB2}$  is the resistor between the W2 and B2 terminals.

$R_{AW2}$  is the resistor between the A2 and W2 terminals.

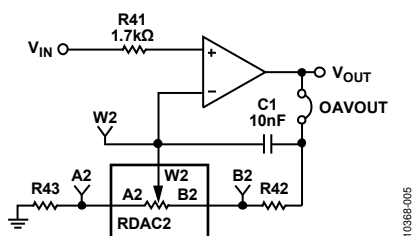

Figure 5. Pseudologarithmic Noninverting Amplifier

R43 and R42 can be used to set the maximum and minimum gain limits.

The inverting amplifier with linear gain is shown in Figure 6, and the gain is defined in Equation 5.

$$G = -\frac{R_{WB2}}{R38} \tag{5}$$

where  $R_{WB2}$  is the resistor between the W2 and B2 terminals.

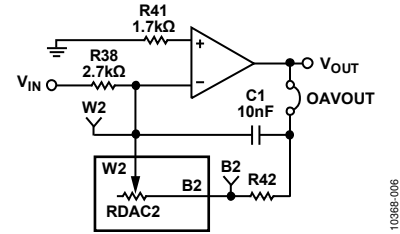

Figure 6. Linear Inverting Amplifier

The inverting amplifier with pseudologarithmic gain is shown in Figure 7, and the gain is defined in Equation 6.

$$G = -\frac{R_{WB2}}{R_{AW2}} \tag{6}$$

where:

$R_{WB2}$  is the resistor between the W2 and B2 terminals.

$R_{AW2}$  is the resistor between the A2 and W2 terminals.

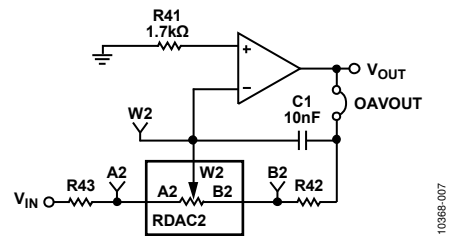

Figure 7. Pseudologarithmic Inverting Amplifier

R43 and R42 can be used to set the maximum and minimum gain limits.

**Output Buffers**

RDAC3 and RDAC4 can be connected to an output buffer as shown Figure 8 and Figure 9, respectively.

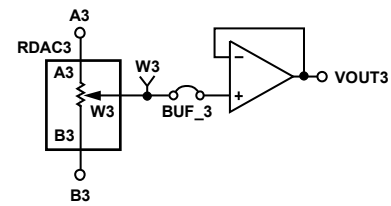

Figure 8. RDAC3

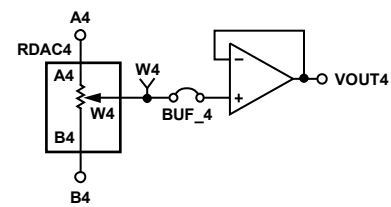

Figure 9. RDAC4

# EVALUATION BOARD SOFTWARE

## INSTALLING THE SOFTWARE

The EVAL-AD5233SDZ evaluation kit includes evaluation board software provided on a CD. The software is compatible with Windows® XP, Windows Vista, and Windows 7 (both 32-bit and 64-bit).

Install the software before connecting the SDP-B board to the USB port of the PC to ensure that the SDP-B board is recognized when it is connected to the PC.

1. Start the Windows operating system and insert the CD.
2. The installation software opens automatically. If it does not, run the **setup.exe** file from the CD.
3. After installation is completed, power up the evaluation board as described in the Power Supplies section.
4. Plug the EVAL-AD5233SDZ into the SDP-B board and the SDP-B board into the PC using the USB cable included in the box.
5. When the software detects the evaluation board, follow the instructions that appear to finalize the installation.

To uninstall the program, click **Start > Control Panel > Add or Remove Programs > AD5233 Eval Board**.

## RUNNING THE SOFTWARE

To run the evaluation board software, do the following:

1. Click **Start > All Programs > Analog Devices > AD5233 > AD5233 Eval Board**.
2. If the SDP-B board is not connected to the USB port when the software is launched, a connectivity error is displayed (see Figure 10). Connect the evaluation board to the USB port of the PC, wait a few seconds, click **Rescan**, and follow the instructions.

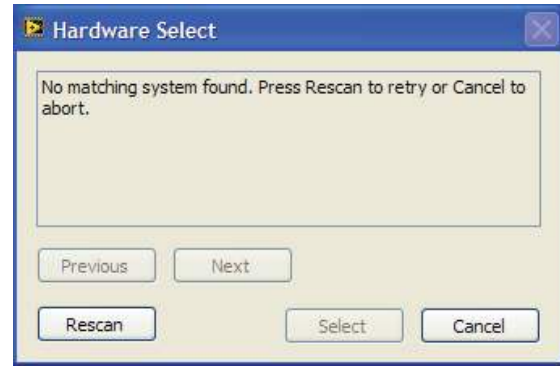

Figure 10. Pop-Up Window Error

The main window of the EVAL-AD5233SDZ software then opens, as shown in Figure 11.

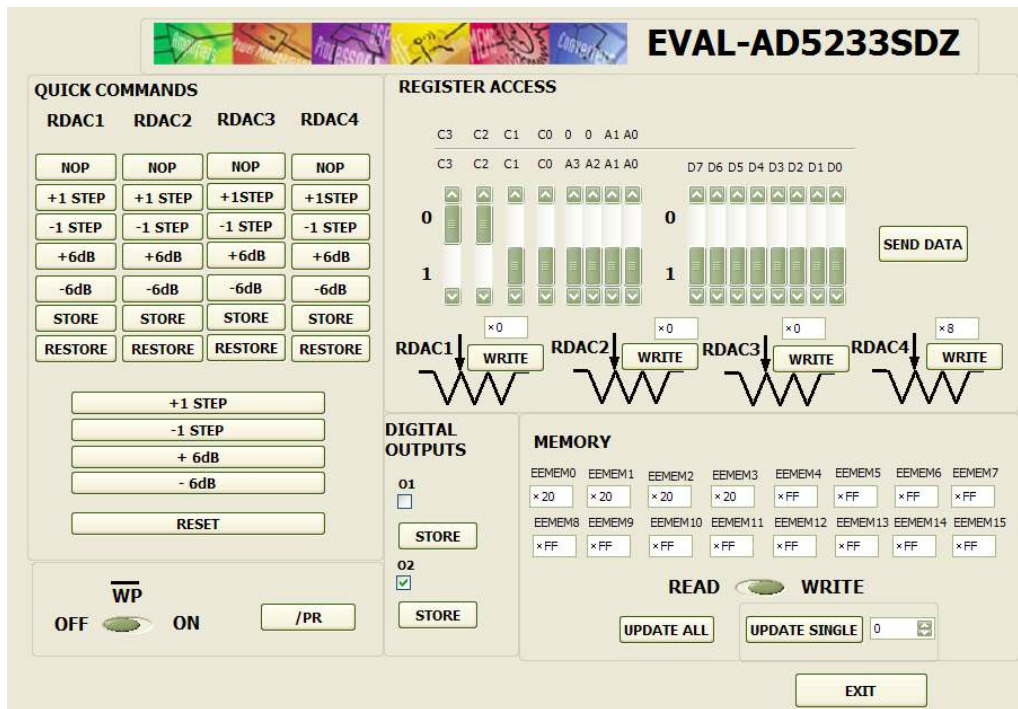

Figure 11. EVAL-AD5233SDZ Software Main Window

## SOFTWARE OPERATION

The main window of the [EVAL-AD5233SDZ](#) software is divided into the following sections: **QUICK COMMANDS**, **REGISTER ACCESS**, **WP**, **DIGITAL OUTPUTS**, and **MEMORY**. The features of the main window are as follows:

- The **QUICK COMMANDS** section allows you to send the [AD5233](#) quick commands directly to the AD5233.
- The **REGISTER ACCESS** section can be used to update the RDAC registers by typing a value into a window and clicking **WRITE**. Alternatively, you can send a customized I<sup>2</sup>C data word by manually switching the scroll bars from 0 to 1 or from 1 to 0, as desired, and then clicking **SEND DATA**. When **WRITE** is clicked or a quick command is executed, a write-read operation is performed, and the values displayed in this section are updated with the actual RDAC register values. This function can be used to verify whether the write operation was completed successfully. The scroll bars are updated upon each write transfer.
- The **WP** section enables or disables the [AD5233 WP](#) pin.
- The **/PR** button generates a pulse in the [PR](#) pin.
- You can pull the digital output pins, O1 and O2, high or low in the **DIGITAL OPUTPUTS** section. Clicking the **STORE** button stores the value in memory.
- The **MEMORY** section displays the data stored in the memory block. The data can be updated by switching the scroll bar from **READ** to **WRITE**, updating a particular window value, clicking **UPDATE ALL** or **UPDATE SINGLE**, and selecting the memory location to write.
- Clicking **EXIT** closes the program but does not reset the part.

EVALUATION BOARD SCHEMATICS AND ARTWORK

10968-010

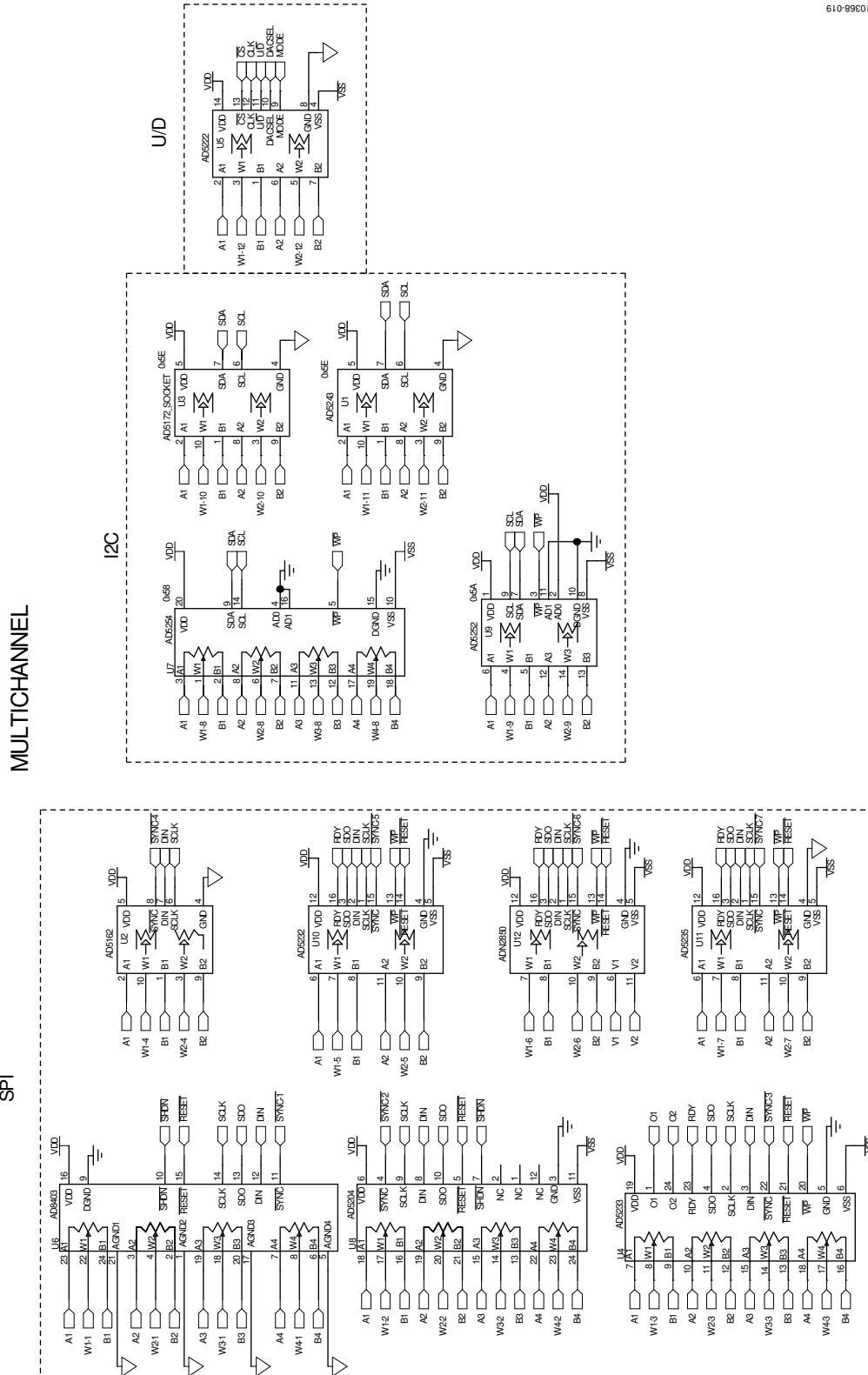

Figure 12. Schematic of Multiboard Digital Potentiometers



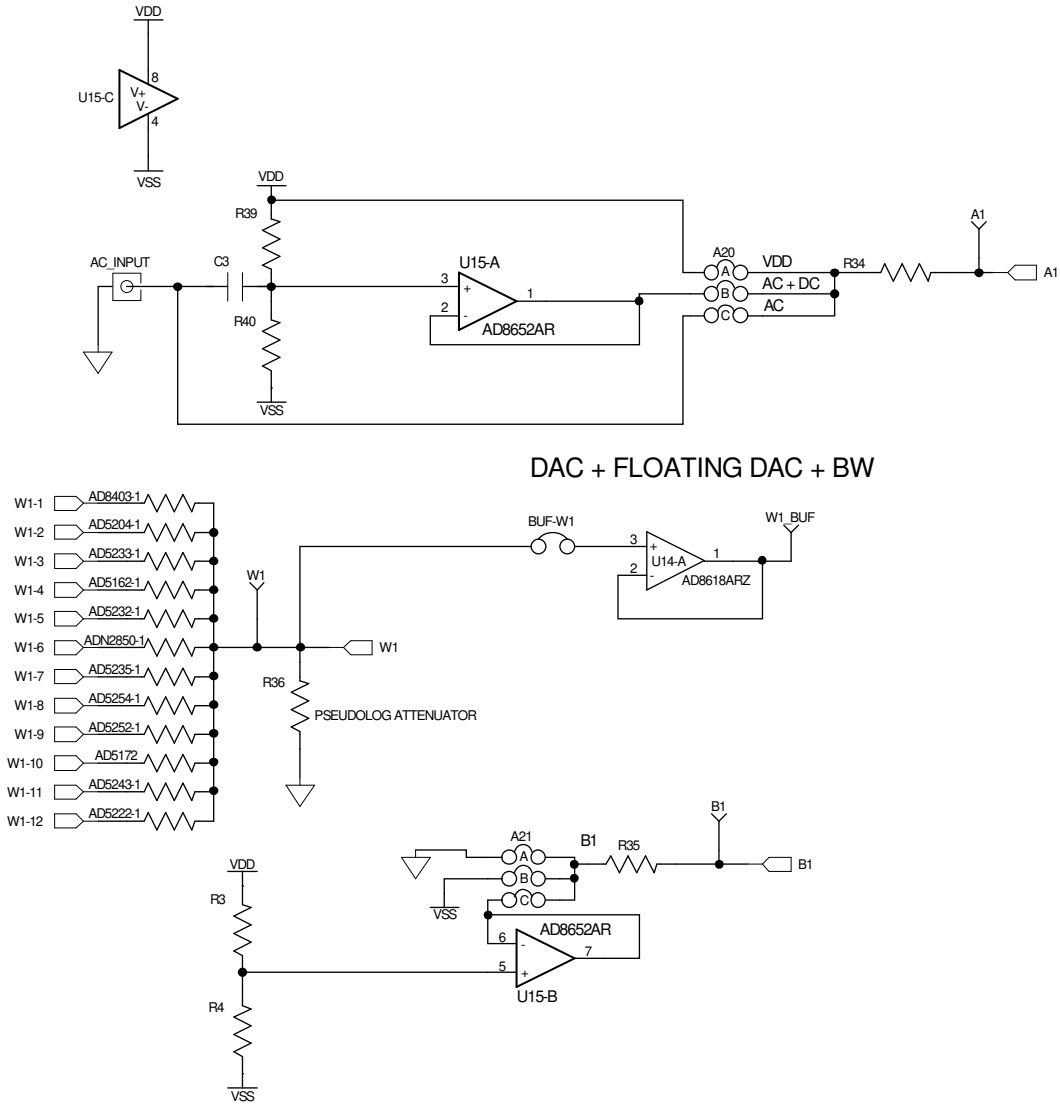

Figure 13. Schematic of Multiboard RDAC0 Circuits

**INVERTING AND NON-INVERTING WITH LINEAR AND PSEUDO-LOG GAIN**

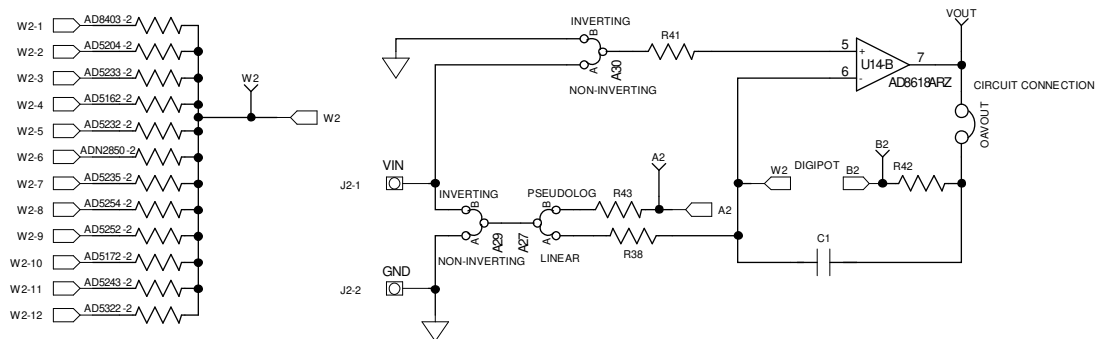
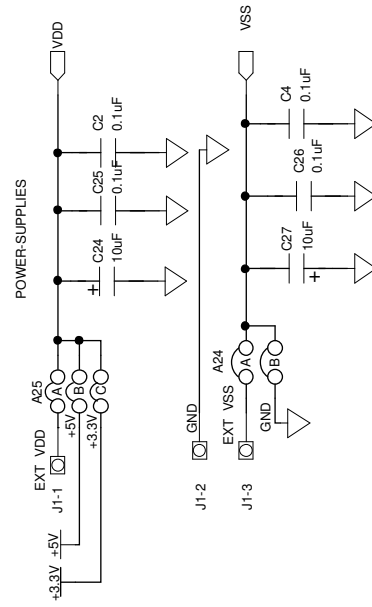

Figure 14. Schematic of Multiboard RDAC1 Circuits

10986-017

POWER-SUPPLY



CURRENT MONITOR

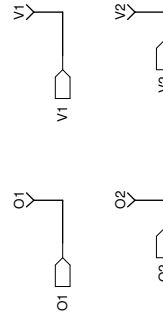

DIGITAL PINS

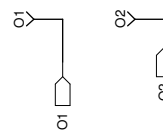

CHANNELS 3 AND 4

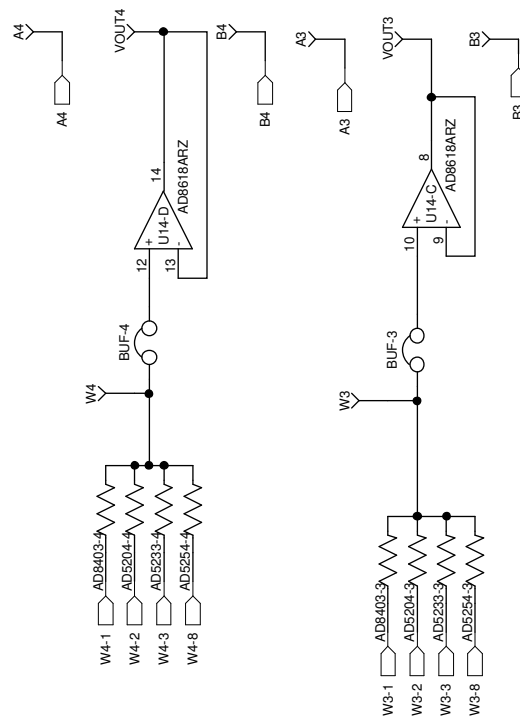

Figure 15. Schematic of AD5233 Power Supplies and Other Channels

10366-018

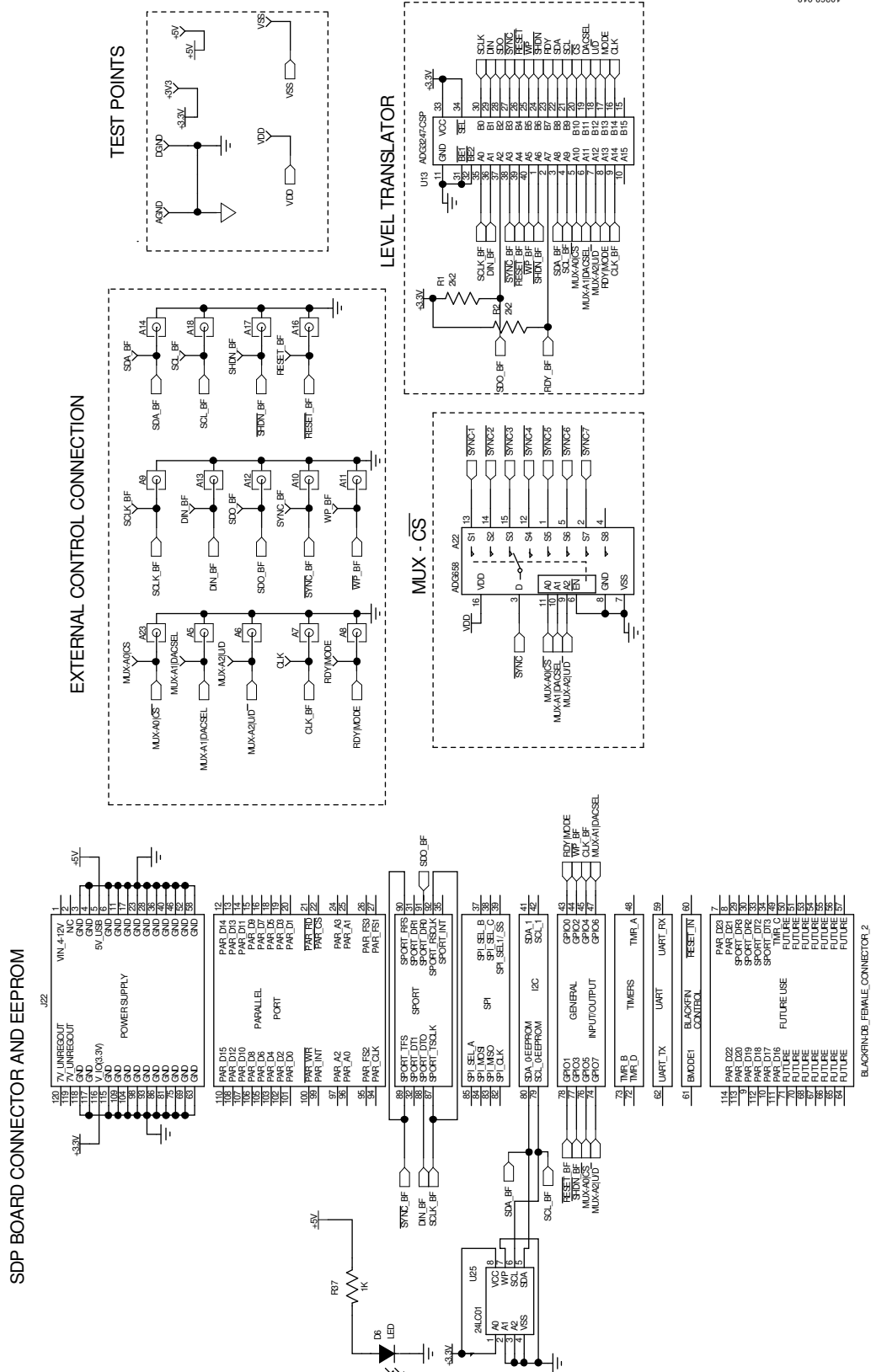

Figure 16. Schematic of SDP-B Connector

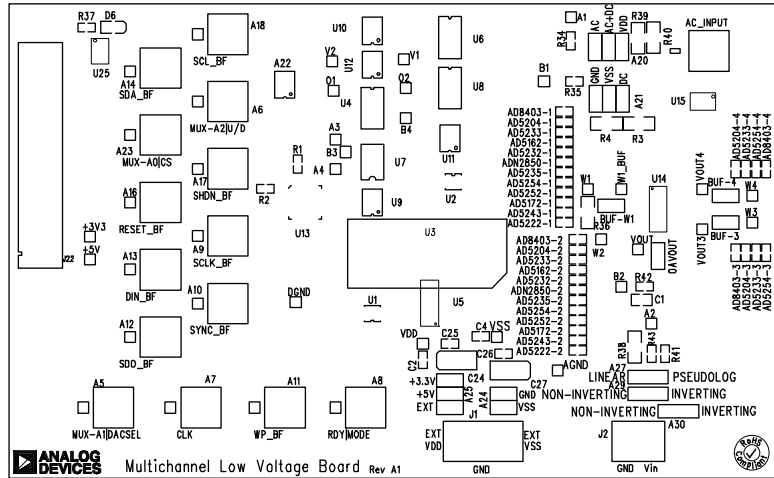

Figure 17. Component Side View

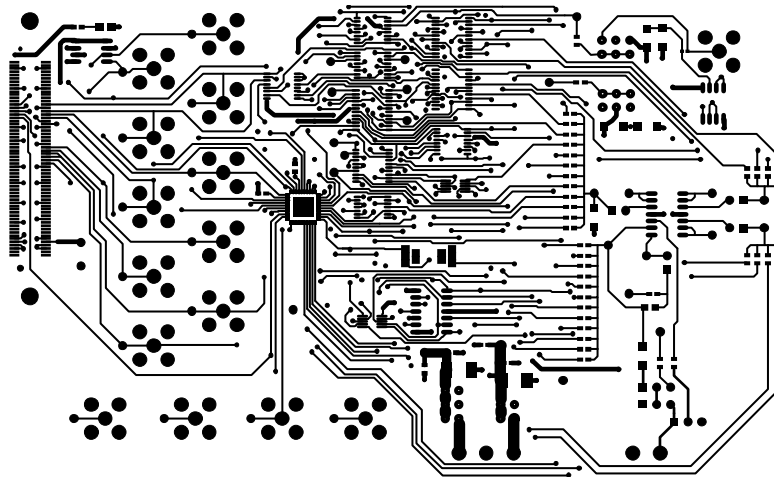

Figure 18. Component Placement Drawing

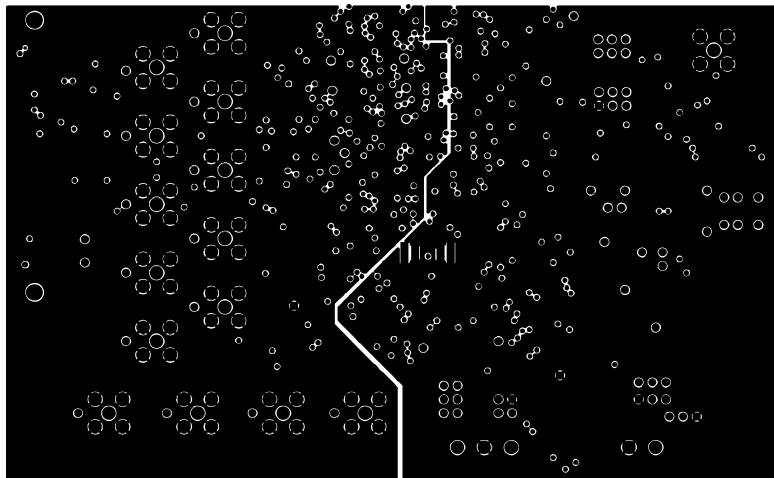

Figure 19. Layer 2 Side PCB Drawing

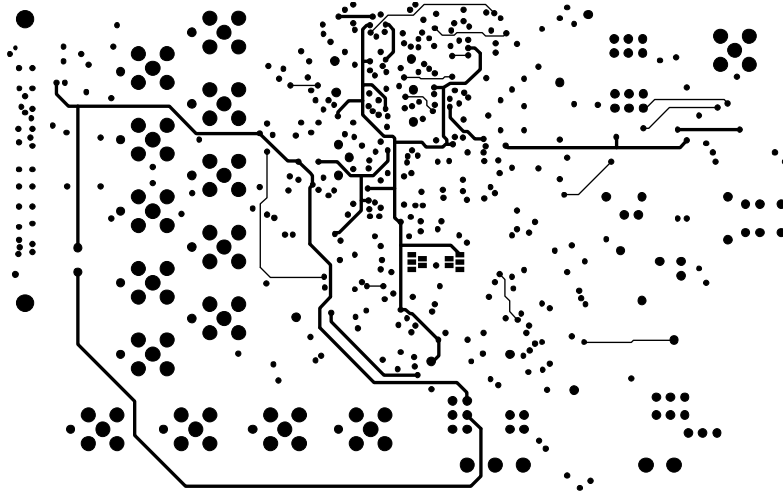

Figure 20. Layer 3 Side PCB Drawing

10388-015

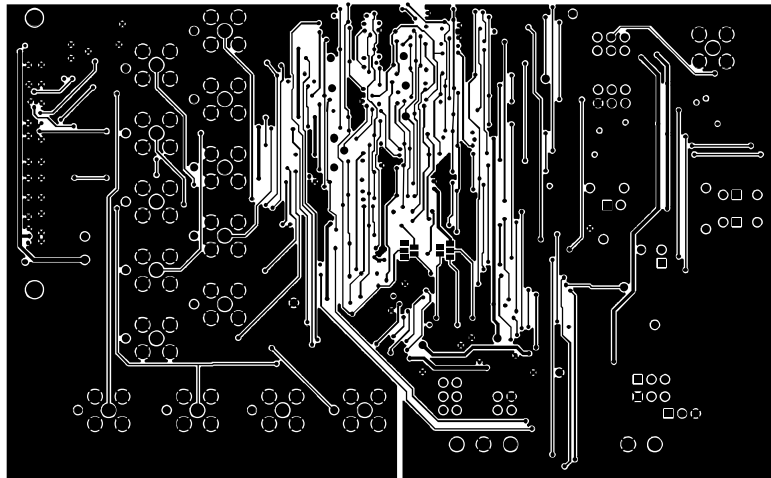

Figure 21. Solder Side PCB Drawing

10388-015

## ORDERING INFORMATION

## BILL OF MATERIALS

Table 7.

Qty	Reference Designator	Description	Supplier <sup>1</sup> /Part Number
1	C1	10 nF capacitor, 0805	FEC 1692285
4	C2, C4, C25, C26	0.1 $\mu$ F capacitor, 0603	FEC 138-2224
1	C3	1 $\mu$ F capacitor, 0402	FEC 1288253
2	C24, C27	10 $\mu$ F capacitor, 1206	FEC 1611967
1	D6	LED, green	FEC 579-0852
1	J1	3-pin connector	FEC 151790
1	J2	2-pin connector	FEC 151789
1	J22	Receptacle, 0.6 mm, 120-way	Digi-Key H1219-ND
4	A20, A21, A24, A25	Header, 2-row, 36 + 36 way, and jumper socket, black	FEC 148-535 and FEC 150-410
3	A27, A29, A30	Header, 1-row, 3-way, and jumper socket, black	FEC 102-2248 and FEC 150-410
4	BUF-W1, OAVOUT, BUF-3, BUF-4	Header, 1-row, 2-way, and jumper socket, black	FEC 102-2247 and FEC 150-410
1	R41	1.78 k $\Omega$ resistor, 0603, 1%	FEC 1170811
2	R1, R2	2.2 k $\Omega$ resistor, 0603, 1%	FEC 933-0810
5	R3, R4, R38, R39, R40	2.7 k $\Omega$ resistor, 1206, 1%	FEC 9337288
36	AD5162-1, AD5162-2, AD5172-1, AD5172-2, AD5204-1, AD5204-2, AD5204-3, AD5204-4, AD5222-1, AD5222-2, AD5232-1, AD5232-2, AD5233-1, AD5233-2, AD5233-3, AD5233-4, AD5235-1, AD5235-2, AD5243-1, AD5243-2, AD5252-1, AD5252-2, AD5233-1, AD5233-2, AD5233-3, AD5233-4, AD8403-1, AD8403-2, AD8403-3, AD8403-4, ADN2850-1, ADN2850-2, R34, R35, R42, R43	0 $\Omega$ resistor, 0603	FEC 9331662
1	R37	1 k $\Omega$ resistor, 0603, 1%	FEC 933-0380
6	3.3 V, 5 V, DGND, AGND, VDD, VSS	Test point, PCB, black, PK100	FEC 873-1128
35	A1, A2, A3, A4, RDY MODE, RESET_BF, SCL_BF, SCLK_BF, SDA_BF, SDO_BF, SHDN_BF, SYNC_BF, MUX-A0 CS, MUX-A1 DACSEL, MUX-A2 U/D, O1, O2, DIN_BF, CLK, B1, B2, B3, B4, V1, V2, VOUT, VOUT2, VOUT3, VOUT4, W1, W1_BUF, W2, W3, W4, WP_BUF	Test point, PCB, red, PK100	FEC 873-1144
1	U1	256-position, dual-channel, I <sup>2</sup> C-compatible digital potentiometer	Analog Devices <a href="#">AD5243</a>
1	U2	256-position, dual-channel, SPI digital potentiometer	Analog Devices <a href="#">AD5162</a>
1	U3	256-position, one-time programmable, dual-channel, I <sup>2</sup> C digital potentiometer	Analog Devices <a href="#">AD5172</a>
1	U4	Nonvolatile, quad, 64-position digital potentiometer	Analog Devices <a href="#">AD5233</a>
1	U5	Dual, increment/decrement digital potentiometer	Analog Devices <a href="#">AD5222</a>
1	U6	4-channel digital potentiometer	Analog Devices <a href="#">AD8403</a>
1	U7	Quad, 256-position, I <sup>2</sup> C, nonvolatile memory digital potentiometer	Analog Devices <a href="#">AD5254</a>
1	U8	4-channel digital potentiometer	Analog Devices <a href="#">AD5204</a>
1	U9	I <sup>2</sup> C, nonvolatile memory, dual, 256-position digital potentiometer	Analog Devices <a href="#">AD5252</a>
1	U10	Nonvolatile memory, dual, 256-position digital potentiometer	Analog Devices <a href="#">AD5232</a>
1	U11	Dual, 1024-position digital potentiometer with nonvolatile memory and SPI interface	Analog Devices <a href="#">AD5235</a>
1	U12	Dual, 1024-position digital rheostat with nonvolatile memory and SPI interface	Analog Devices <a href="#">ADN2850</a>

Qty	Reference Designator	Description	Supplier <sup>1</sup> /Part Number
1	U13	2.5 V/3.3 V, 16-bit (dual 8-bit), two-port level translator bus switch	Analog Devices <a href="#">ADG3247</a>
1	U14	Precision, 20 MHz, CMOS, quad, rail-to-rail operational amplifier	Analog Devices <a href="#">AD8618</a>
1	U15	50 MHz, precision, low distortion, low noise CMOS amplifier	Analog Devices <a href="#">AD8652</a>
1	U25	24LC64 EEPROM	FEC 975-8070
1	A22	3 V/5 V, ± 5 V CMOS, 8-channel analog multiplexer	Analog Devices <a href="#">ADG658</a>

<sup>1</sup> FEC refers to Farnell Electronic Component Distributors; Digi-Key refers to Digi-Key Corporation.

**RELATED LINKS**

Resource	Description
<a href="#">AD5243</a>	Product Page, 256-Position Dual-Channel I <sup>2</sup> C Compatible Digital Potentiometer
<a href="#">AD5162</a>	Product Page, 256-Position Dual-Channel SPI Digital Potentiometer
<a href="#">AD5233</a>	Product Page, Nonvolatile, Quad, 64-Position Digital Potentiometer
<a href="#">AD5222</a>	Product Page, Dual, Increment/Decrement Digital Potentiometer
<a href="#">AD8403</a>	Product Page, 4-Channel Digital Potentiometer
<a href="#">AD5254</a>	Product Page, Quad 256-Position I <sup>2</sup> C Nonvolatile Memory, Digital Potentiometer
<a href="#">AD5204</a>	Product Page, 4-Channel Digital Potentiometer
<a href="#">AD5252</a>	Product Page, I <sup>2</sup> C, Nonvolatile Memory, Dual 256-Position Digital Potentiometer
<a href="#">AD5232</a>	Product Page, Nonvolatile Memory, Dual, 256-Position Digital Potentiometer
<a href="#">AD5235</a>	Product Page, Nonvolatile Memory, Dual 1024-Position Digital Potentiometer
<a href="#">ADN2850</a>	Product Page, Nonvolatile Memory, Dual 1024-Position Digital Resistor
<a href="#">ADG3247</a>	Product Page, 2.5 V/3.3 V, 16-Bit (Dual 8-Bit), 2-Port Level Translator, Bus Switch
<a href="#">ADG658</a>	Product Page, 3 V/5 V ± 5 V CMOS 8-Channel Analog Multiplexer
<a href="#">AD8652</a>	Product Page, 50 MHz, Precision, Low Distortion, Low Noise CMOS Amplifier
<a href="#">AD8618</a>	Product Page, Precision 20 MHz CMOS Quad Rail-to-Rail Operational Amplifier

## NOTES

I<sup>2</sup>C refers to a communications protocol originally developed by Philips Semiconductors (now NXP Semiconductors).

**ESD Caution**

**ESD (electrostatic discharge) sensitive device.** Charged devices and circuit boards can discharge without detection. Although this product features patented or proprietary protection circuitry, damage may occur on devices subjected to high energy ESD. Therefore, proper ESD precautions should be taken to avoid performance degradation or loss of functionality.

**Legal Terms and Conditions**

By using the evaluation board discussed herein (together with any tools, components documentation or support materials, the "Evaluation Board"), you are agreeing to be bound by the terms and conditions set forth below ("Agreement") unless you have purchased the Evaluation Board, in which case the Analog Devices Standard Terms and Conditions of Sale shall govern. Do not use the Evaluation Board until you have read and agreed to the Agreement. Your use of the Evaluation Board shall signify your acceptance of the Agreement. This Agreement is made by and between you ("Customer") and Analog Devices, Inc. ("ADI"), with its principal place of business at One Technology Way, Norwood, MA 02062, USA. Subject to the terms and conditions of the Agreement, ADI hereby grants to Customer a free, limited, personal, temporary, non-exclusive, non-sublicensable, non-transferable license to use the Evaluation Board FOR EVALUATION PURPOSES ONLY. Customer understands and agrees that the Evaluation Board is provided for the sole and exclusive purpose referenced above, and agrees not to use the Evaluation Board for any other purpose. Furthermore, the license granted is expressly made subject to the following additional limitations: Customer shall not (i) rent, lease, display, sell, transfer, assign, sublicense, or distribute the Evaluation Board; and (ii) permit any Third Party to access the Evaluation Board. As used herein, the term "Third Party" includes any entity other than ADI, Customer, their employees, affiliates and in-house consultants. The Evaluation Board is NOT sold to Customer; all rights not expressly granted herein, including ownership of the Evaluation Board, are reserved by ADI. CONFIDENTIALITY. This Agreement and the Evaluation Board shall all be considered the confidential and proprietary information of ADI. Customer may not disclose or transfer any portion of the Evaluation Board to any other party for any reason. Upon discontinuation of use of the Evaluation Board or termination of this Agreement, Customer agrees to promptly return the Evaluation Board to ADI. ADDITIONAL RESTRICTIONS. Customer may not disassemble, decompile or reverse engineer chips on the Evaluation Board. Customer shall inform ADI of any occurred damages or any modifications or alterations it makes to the Evaluation Board, including but not limited to soldering or any other activity that affects the material content of the Evaluation Board. Modifications to the Evaluation Board must comply with applicable law, including but not limited to the RoHS Directive. TERMINATION. ADI may terminate this Agreement at any time upon giving written notice to Customer. Customer agrees to return to ADI the Evaluation Board at that time. LIMITATION OF LIABILITY. THE EVALUATION BOARD PROVIDED HEREUNDER IS PROVIDED "AS IS" AND ADI MAKES NO WARRANTIES OR REPRESENTATIONS OF ANY KIND WITH RESPECT TO IT. ADI SPECIFICALLY DISCLAIMS ANY REPRESENTATIONS, ENDORSEMENTS, GUARANTEES, OR WARRANTIES, EXPRESS OR IMPLIED, RELATED TO THE EVALUATION BOARD INCLUDING, BUT NOT LIMITED TO, THE IMPLIED WARRANTY OF MERCHANTABILITY, TITLE, FITNESS FOR A PARTICULAR PURPOSE OR NON-INFRINGEMENT OF INTELLECTUAL PROPERTY RIGHTS. IN NO EVENT WILL ADI AND ITS LICENSORS BE LIABLE FOR ANY INCIDENTAL, SPECIAL, INDIRECT, OR CONSEQUENTIAL DAMAGES RESULTING FROM CUSTOMER'S POSSESSION OR USE OF THE EVALUATION BOARD, INCLUDING BUT NOT LIMITED TO LOST PROFITS, DELAY COSTS, LABOR COSTS OR LOSS OF GOODWILL. ADI'S TOTAL LIABILITY FROM ANY AND ALL CAUSES SHALL BE LIMITED TO THE AMOUNT OF ONE HUNDRED US DOLLARS (\$100,000). EXPORT. Customer agrees that it will not directly or indirectly export the Evaluation Board to another country, and that it will comply with all applicable United States federal laws and regulations relating to exports. GOVERNING LAW. This Agreement shall be governed by and construed in accordance with the substantive laws of the Commonwealth of Massachusetts (excluding conflict of law rules). Any legal action regarding this Agreement will be heard in the state or federal courts having jurisdiction in Suffolk County, Massachusetts, and Customer hereby submits to the personal jurisdiction and venue of such courts. The United Nations Convention on Contracts for the International Sale of Goods shall not apply to this Agreement and is expressly disclaimed.