

REVISIONS

P	LTR	DESCRIPTION	DATE	DWN	APVD
	J3	REVISED PER ECN-22-150900	27APR2022	RK	CSD

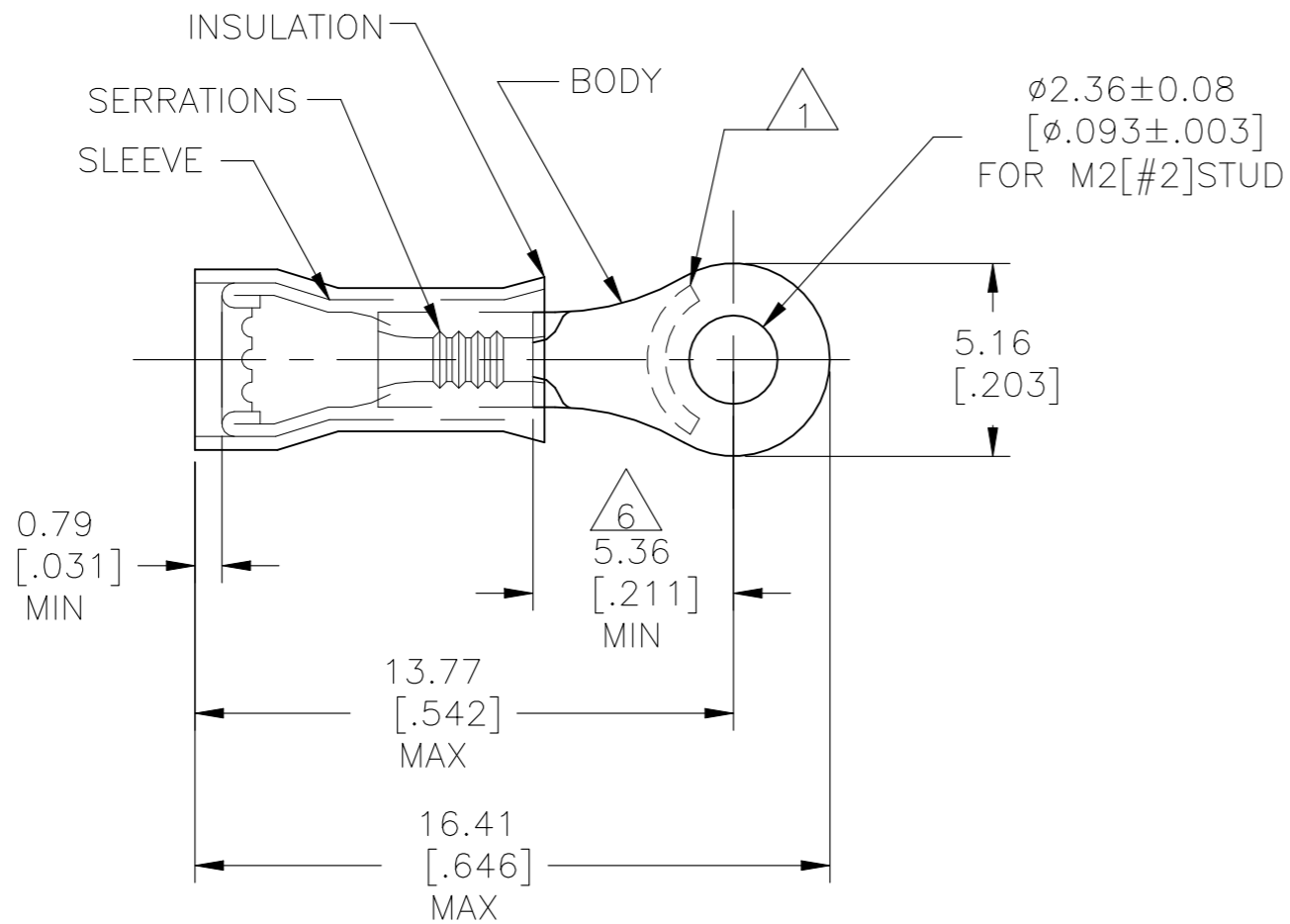

- 1 STAMP " AMP " LOCATED APPROX AS SHOWN.
- 2 WIRE INSULATION DIA : 1.27-2.08[.050-.082]
- 3 TONGUE MATERIAL THK: 0.46±0.05[.018±.002]
- 4 BODY & SLEEVE : TIN 0.00254[.000100] MIN EXT THK PER ASTM B545.
- 5 MATERIAL: BODY & SLEEVE- CU PER ASTM B152. INSULATION - NYLON PER ASTM D4066. COLOR - YELLOW.
- 6 APPLIES FROM EDGE OF METAL WIRE BARREL TO THE CENTER OF STUD HOLE.
- 7 NOTE DELETED.

4000	323913 ON TAPE REELED	2-323913-1
1000	LOOSE PIECE	323913
QTY	PACKAGE TYPE	PART NO.

CUSTOMER SERVICE SYSTEMS		MAX RECOMMENDED OPERATING TEMPERATURE: 105°C[221°F] MAX	THIS DRAWING IS A CONTROLLED DOCUMENT.		DWN JR RUTH 14JAN10	<b>STE</b> TE Connectivity				
FOR ADDITIONAL PRODUCT INFORMATION OR COPIES OF DRAWINGS AND TECHNICAL DOCUMENTS	PRODUCT INFORMATION CENTER 1-800-522-6752	VOLTAGE RATING: 300 V MAX	DIMENSIONS: mm [INCHES]	TOLERANCES UNLESS OTHERWISE SPECIFIED:	CHK T MICHELUTTI 15JAN10				NAME	
FOR APPLICATION TOOLING INFORMATION	TOOLING ASSISTANCE CENTER 1-800-722-1111	CIRCULAR MIL AREA: 0.10-0.41mm²[202-810] STRANDED		0 PLC ± - 1 PLC ± - 2 PLC ± 0.20[.008] 3 PLC ± - 4 PLC ± - ANGLES ± -	APVD T MICHELUTTI 15JAN10	PRODUCT SPEC				
FOR ORDER ENTRY	1-800-526-5142	THIS DRAWING IS A CONTROLLED DOCUMENT FOR AMP INCORPORATED. IT IS SUBJECT TO CHANGE AND THE CONTROLLING ENGINEERING ORGANIZATION SHOULD BE CONTACTED FOR THE LATEST REVISION.	MATERIAL	FINISH	PRODUCT SPEC	APPLICATION SPEC	SIZE	CAGE CODE	DRAWING NO	RESTRICTED TO
			5	4	---	---	A3	00779	C-323913	---
					CUSTOMER DRAWING		SCALE	SHEET	REV	
							4:1	1 OF 1	J3	