

10	9	8	7
MATERIAL NUMBER	WIRE AWG	INSUL DIA O.D.	
845020008	18-14	.053[1.35] - .134[3.40]	

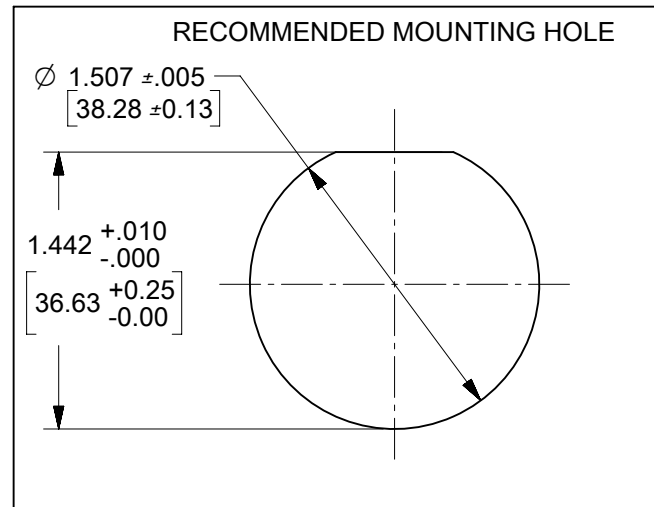
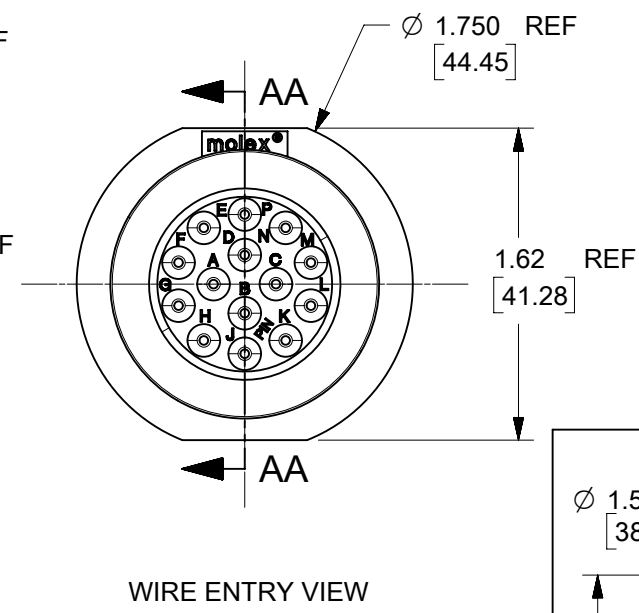
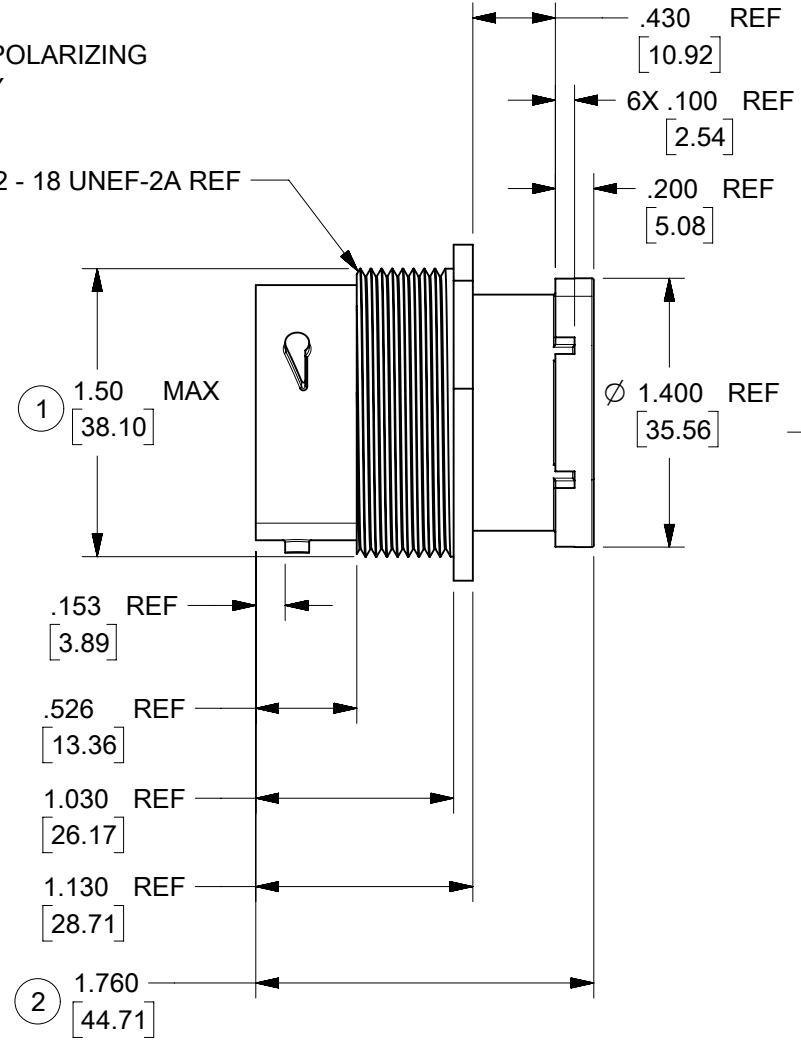
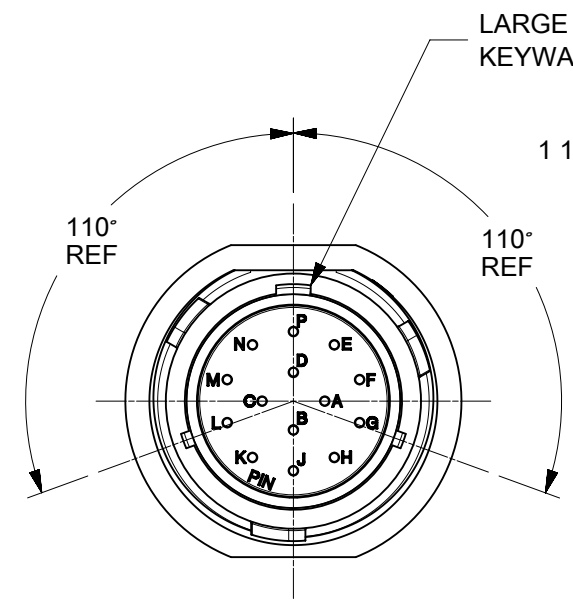
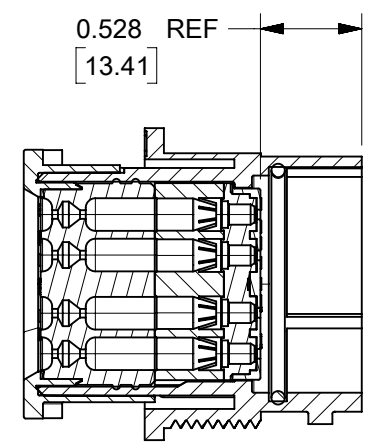
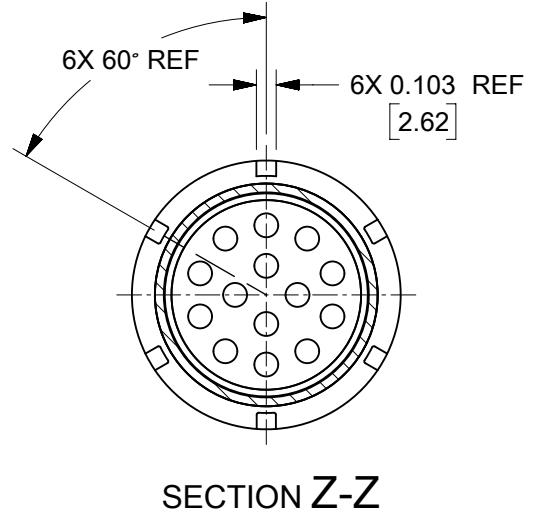
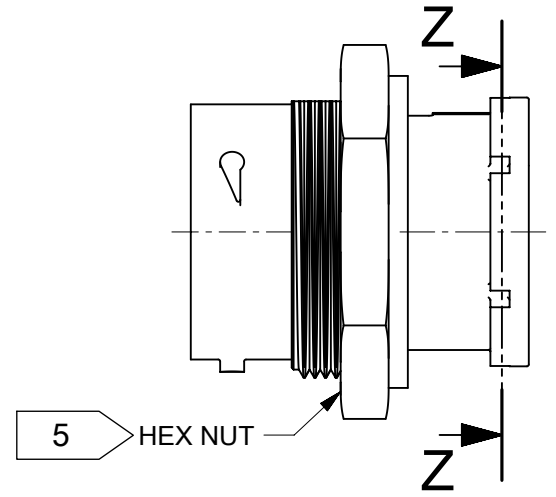
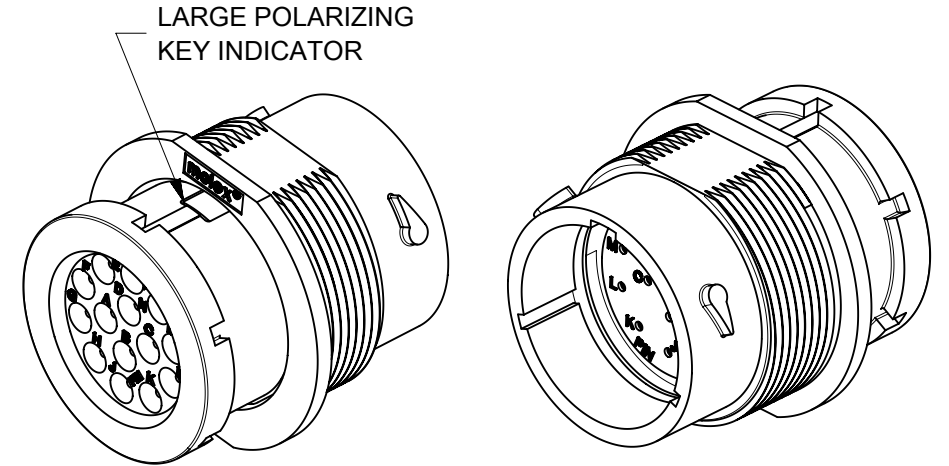

SECTION AA-AA

- NOTES:
- MATERIALS:
HOUSINGS: POLYESTER (PBT), GLASS FILLED, UL94V-0 & POLYETHERIMIDE (PEI), UNFILLED, UL94V-0.
COLOR, UNLESS OTHERWISE SPECIFIED: BLACK
SEALS: SILICONE RUBBER
COLOR: RUST RED
 - PRODUCT SPECIFICATION: PS-84501-001.
 - MATES WITH: SERIES 84507 PLUG CONNECTOR.
 - USE CONNECTOR WITH MALE CRIMP TERMINAL SERIES 84524.
 - HEX NUT SOLD SEPARATELY, OPTIONAL FOR PANEL MOUNTING MOLEX MATERIAL NUMBER 845020004.
 - RECOMMENDED PANEL THICKNESS .062[1.58] TO .187[4.76]

LAST INSPECTION NUMBER: ②

THIS DRAWING CONTAINS INFORMATION THAT IS PROPRIETARY TO MOLEX ELECTRONIC TECHNOLOGIES, LLC AND SHOULD NOT BE USED WITHOUT WRITTEN PERMISSION											
DIMENSION UNITS		SCALE		CURRENT REV DESC:							
HYBRID		1:1		EC NO: 623621							
GENERAL TOLERANCES (UNLESS SPECIFIED)				DRWN: AJOBRIEN				2019/08/07			
4 PLACES ±		±		CHK'D: IOCONNELL				2019/10/14			
3 PLACES ±		± 0.015		APPR: IOCONNELL				2019/10/16			
2 PLACES ±		0.38 ± 0.02		INITIAL REVISION:							
1 PLACE ±		0.5 ±		DRWN: BRUPERT				2008/02/08			
0 PLACES ±		±		APPR: RDEROSS				2008/02/08			
ANGULAR TOL ± 1.0°				THIRD ANGLE PROJECTION		DRAWING		SERIES		DOCUMENT NUMBER	
DRAFT WHERE APPLICABLE MUST REMAIN WITHIN DIMENSIONS						B-SIZE		84502		SD-84502-002	
								MATERIAL NUMBER		DOC TYPE DOC PART REVISION	
								SEE CHART		PSD 001 C2	
								CUSTOMER		SHEET NUMBER	
								GENERAL MARKET		1 OF 1	