

STANDARD PROFILE MAGNETIC JACK
GIGABIT ETHERNET W/LEDS
AND W/SHIELD TABS TOP AND SIDE

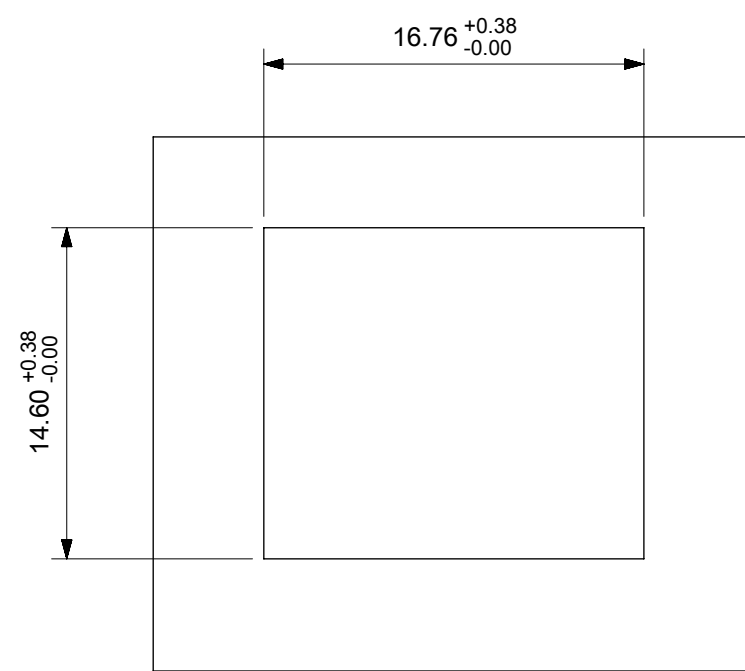

SUGGESTED PANEL CUT-OUT

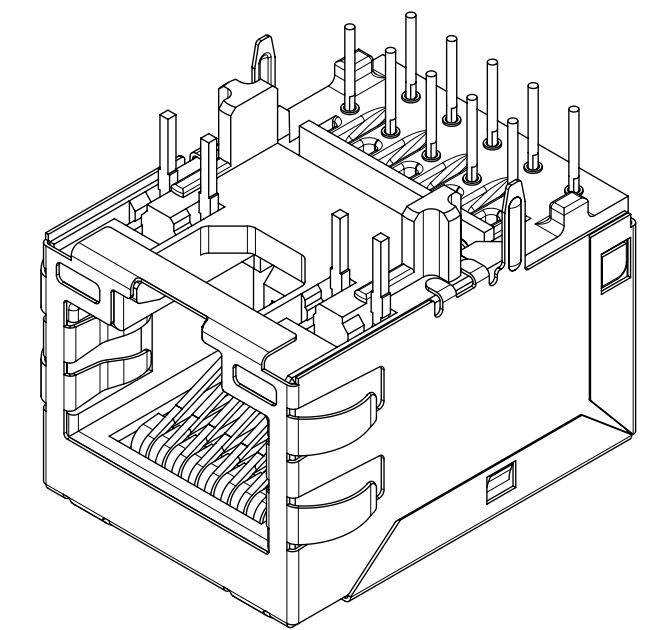
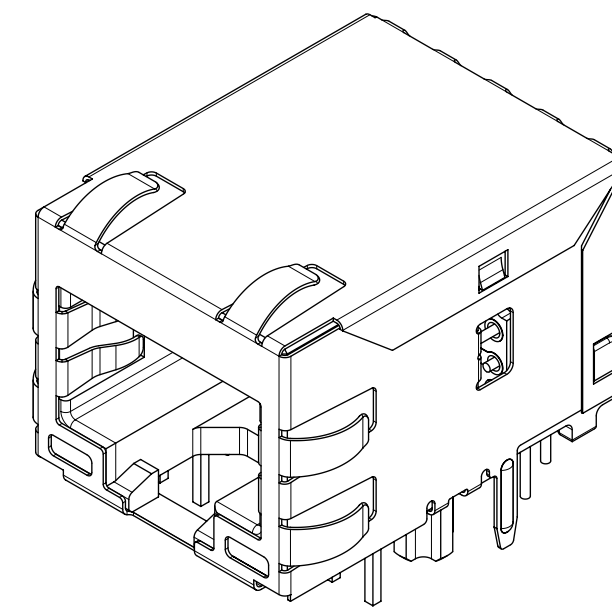
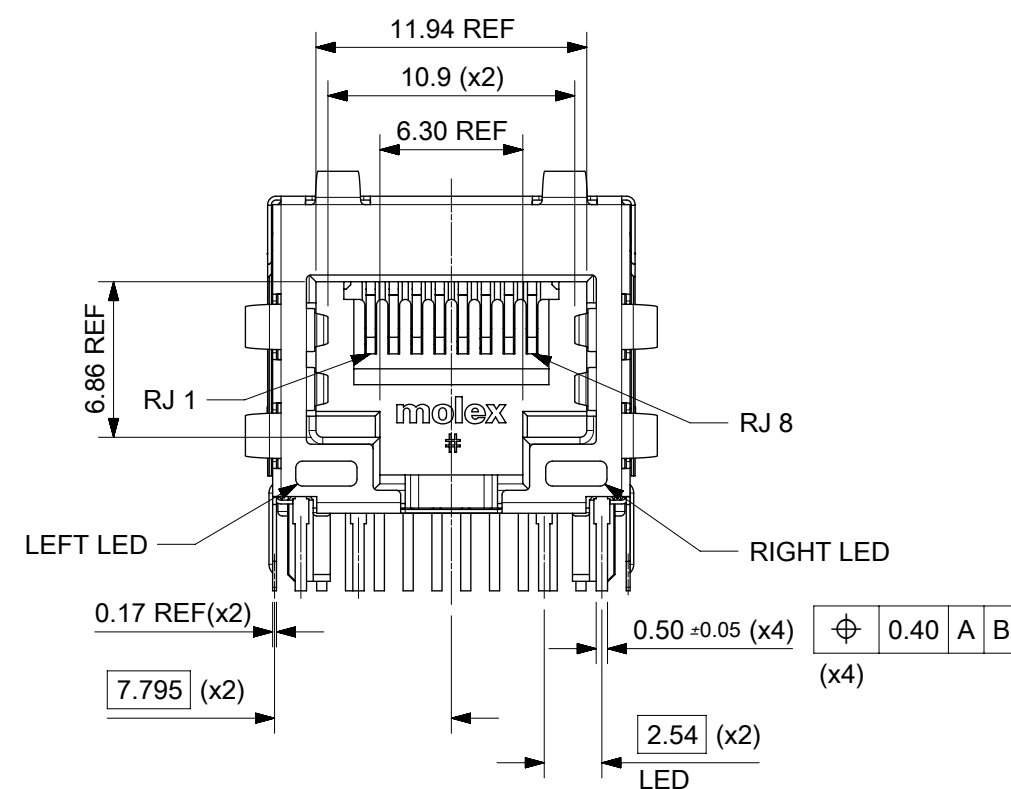
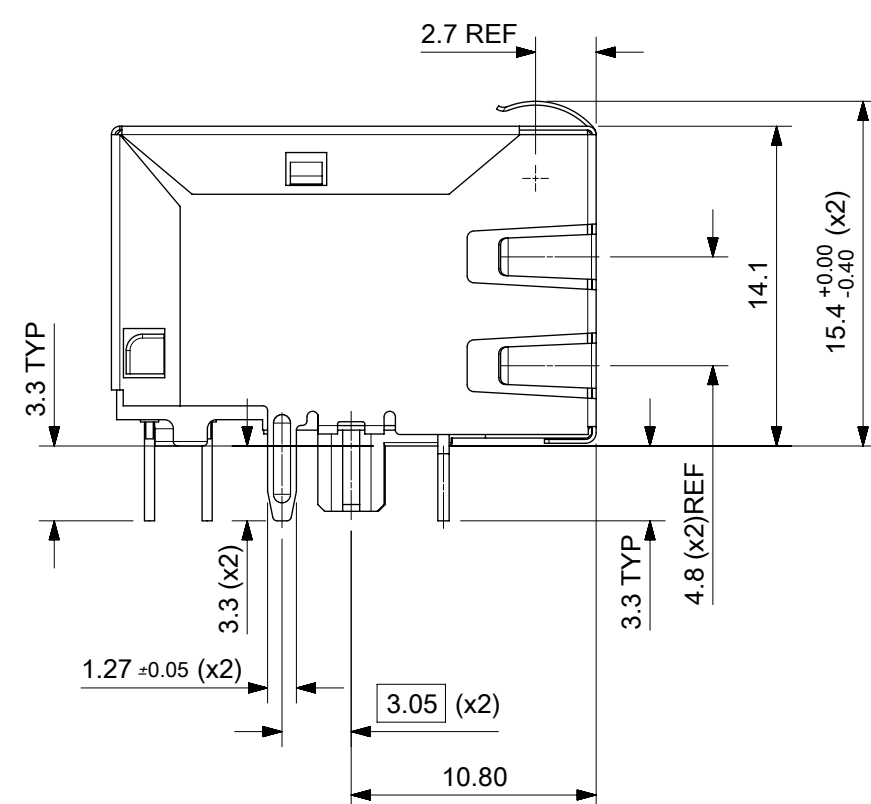
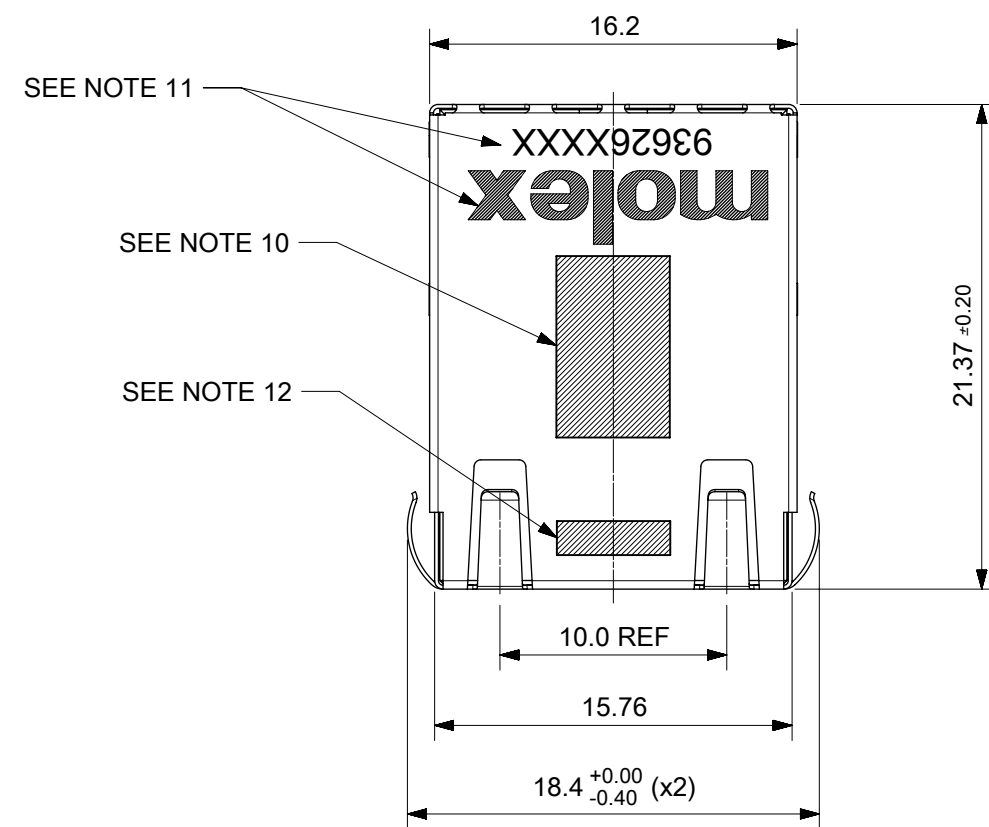
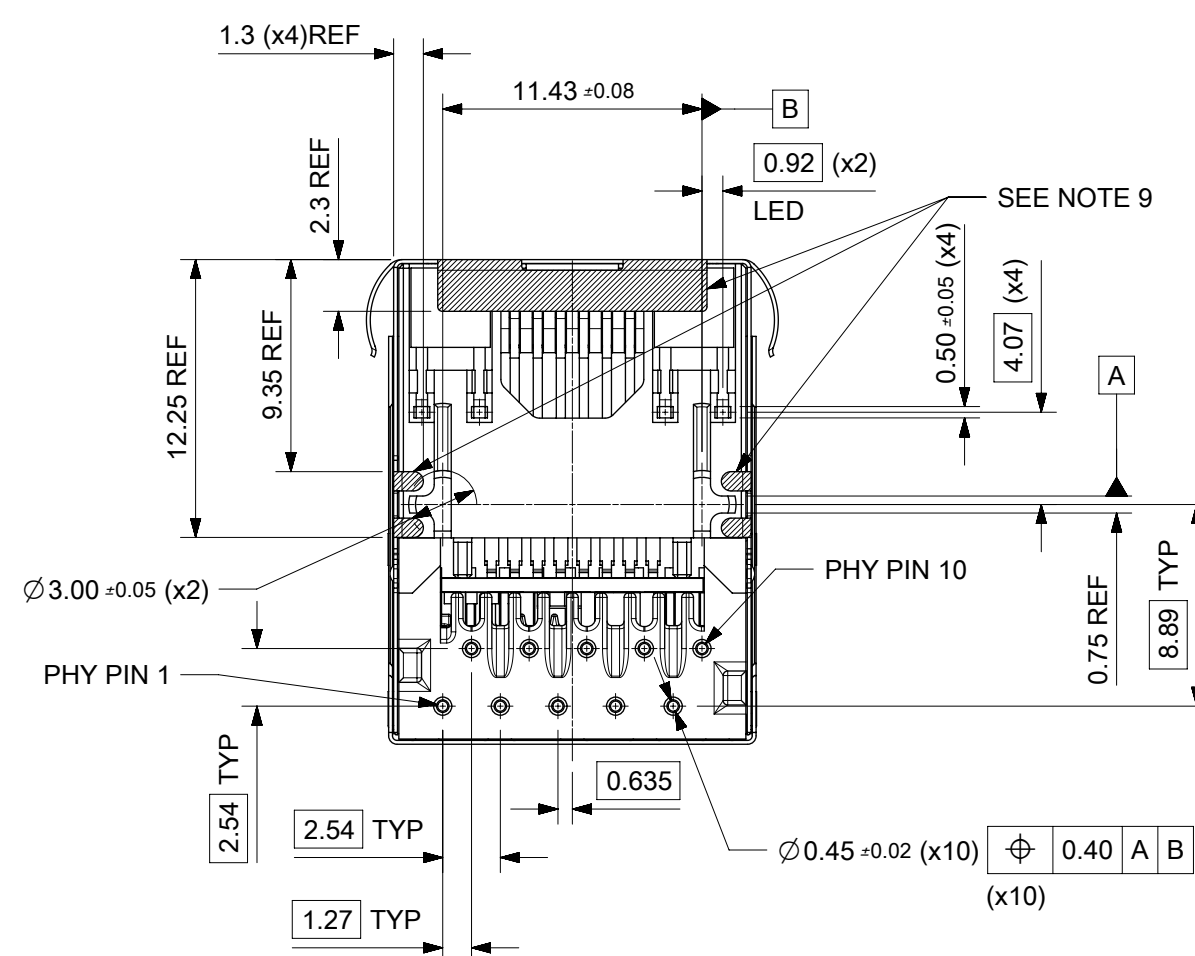

NOTES:

- 1 - SHIELD MATERIAL: 0.17 mm THICK BRASS PRE-PLATED WITH NICKEL
SOLDER TABS POST DIPPED WITH MIN. 1.27 μm TIN
- 2 - HOUSING MATERIAL: LCP, BLACK, UL 94 V-0
- 3 - TERMINAL MATERIAL: PHOSPHOR BRONZE
RJ45 CONTACTS PLATING: BASE NICKEL PLATED WITH GOLD
FLASH OVER PALLADIUM NICKEL. REFER TO 934620001 PSP
PHY SOLDER TAILS: COPPER ALLOY
- 4 - MATING INTERFACE ACCORDING TO IEC 60603-7 & TIA-1096-A
- 5 - PRODUCT SPECIFICATION: 934620001 PSP
- 6 - PACKAGING SPECIFICATION: 934620001 PSK TRAY
- 7 - STAND OFF TO SYSTEM BOARD 0.30 mm MINIMUM
- 8 - RECOMMENDED PCB THICKNESS: 1.57 mm
- 9 - SHIELD: AVOID ROUTING TRACES
OR PLACING ANY VIAS BELOW THESE AREAS
- 10 - AREA FOR PICK AND PLACE: 5.0 mm X 8.0 mm
- 11 - INSCRIPTION MARKED BY LASER:
1st : MOLEX
2nd : P/N (SEE CHART)
- 12 - DATE CODE(DAY/WEEK/YEAR)

THIS DRAWING CONTAINS INFORMATION THAT IS PROPRIETARY TO MOLEX ELECTRONIC TECHNOLOGIES, LLC AND SHOULD NOT BE USED WITHOUT WRITTEN PERMISSION									
DIMENSION UNITS		SCALE		CURRENT REV DESC: UPDATE TITLE BLOCK					
mm		3:1							
GENERAL TOLERANCES (UNLESS SPECIFIED)				EC NO: 174255					
ANGULAR TOL ± 2.0°				4 PLACES ±		DRWN: DSHEA		2018/03/27	
				3 PLACES ±		CHK'D: SMCGREEVY		2018/04/03	
				2 PLACES ± 0.1		APPR: DBYRNES		2018/04/04	
				1 PLACE ± 0.2		INITIAL REVISION:			
				0 PLACES ±		DRWN: DSHEA		2017/12/20	
						APPR: DBYRNES		2018/02/01	
DRAFT WHERE APPLICABLE MUST REMAIN WITHIN DIMENSIONS		THIRD ANGLE PROJECTION		DRAWING		SERIES		MATERIAL NUMBER	
				A2-SIZE		93626		SEE CHART	
DOCUMENT STATUS				DOC TYPE		DOC PART		REVISION	
P1				PSD		000		B	
RELEASE DATE		CUSTOMER		SHEET NUMBER					
2018/04/04		GENERAL MARKET		1 OF 3					
10:20:17									

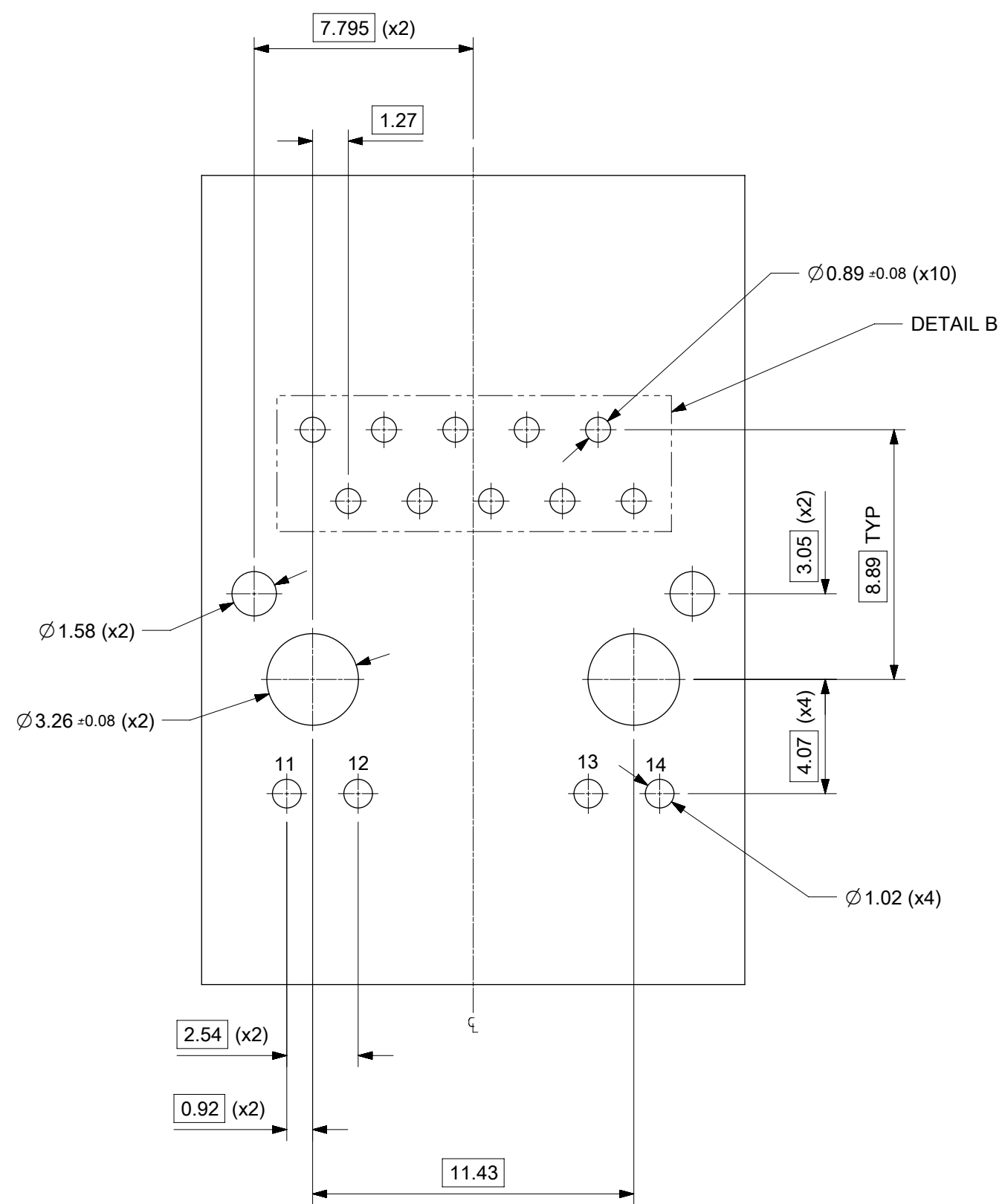

SUGGESTED BOARD LAYOUT
GIGABIT VERSION
COMPONENT SIDE
ALL DIMS REFERENCE DIMS

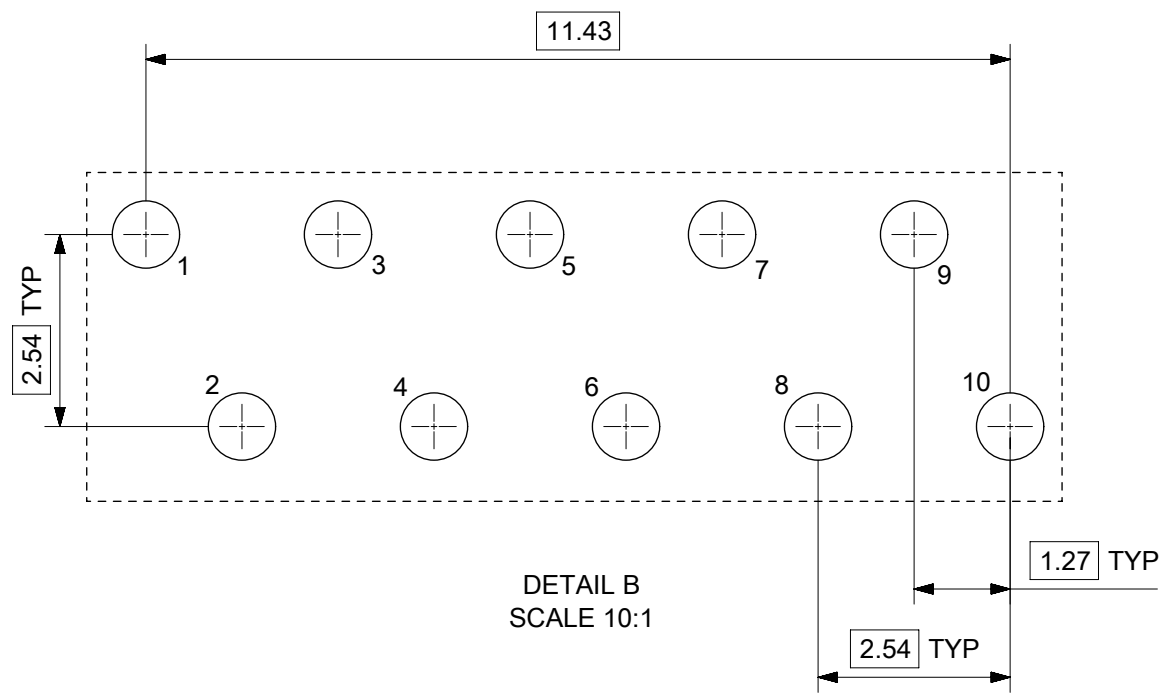

PIN CONFIGURATION
FOR GIGABIT VERSION

PART NUMBER	LEFT LED	RIGHT LED
93626-8508	GREEN/YELLOW	GREEN/YELLOW

THIS DRAWING CONTAINS INFORMATION THAT IS PROPRIETARY TO MOLEX ELECTRONIC TECHNOLOGIES, LLC AND SHOULD NOT BE USED WITHOUT WRITTEN PERMISSION

DIMENSION UNITS	SCALE	CURRENT REV DESC: UPDATE TITLE BLOCK						
mm	5:1	<div style="text-align: center;">molex</div> STD MXMAG 8 CORE GIG W/LEDS & W/SHIELD TABS						
GENERAL TOLERANCES (UNLESS SPECIFIED)								
ANGULAR TOL	± 2.0°	EC NO: 174255	2018/03/27	PRODUCT CUSTOMER DRAWING				
4 PLACES	±	DRWN: DSHEA	2018/04/03					
3 PLACES	±	CHK'D: SMCGREEVY	2018/04/04					
2 PLACES	± 0.1	APPR: DBYRNES	2018/04/04	DOCUMENT NUMBER				
1 PLACE	± 0.2	INITIAL REVISION:			936260004			
0 PLACES	±	DRWN: DSHEA	2017/12/20	DOC TYPE				
DRAFT WHERE APPLICABLE MUST REMAIN WITHIN DIMENSIONS		THIRD ANGLE PROJECTION	DRAWING	SERIES	MATERIAL NUMBER	CUSTOMER	DOC PART	REVISION
			A2-SIZE	93626	SEE CHART	GENERAL MARKET	000	B
								SHEET NUMBER
								2 OF 3

DOCUMENT STATUS	P1	RELEASE DATE	2018/04/04	10:20:17
-----------------	----	--------------	------------	----------

Description	Value	
OCL @100 kHz, 0.1 V, 8 mA DC bias (-40°C to +85°C)	350 μH min.	
Turns ratio	1CT:1CT	
Transmission characteristics @ 25°C, all four pairs		
Insertion Loss		
Frequency f, (MHz)	Limits (dB max.)	Typical Values (dB max.)
1.0 - 9.9	0.4+0.1*log(f)	0.5 @ 10 MHz
10 - 49.9	0.5+0.3*log(f/10)	0.7 @ 50 MHz
50 - 79.9	1+1.4*log(f/80)	1.0 @ 80 MHz
80 - 100	1.3+3*log(f/100)	1.3 @ 100 MHz
Return Loss		
Frequency f, (MHz)	Limits (dB min.)	Typical Values (dB min.)
1.0 - 39.9	18	18 @ 40 MHz
40 - 100	12-20*log(f/80)	10 @ 100 MHz
CMR		
Frequency f, (MHz)	Limits (dB min.)	Typical Values (dB min.)
1.0 - 100	30	30 @ 100 MHz
NEXT		
Frequency f, (MHz)	Limits (dB min.)	Typical Values (dB min.)
1.0 - 39.9	35	35 @ 40 MHz
40 - 100	33-20*log(f/50)	27 @ 100 MHz
Isolation PHY to wire side	2.25 kV DC/60sec	

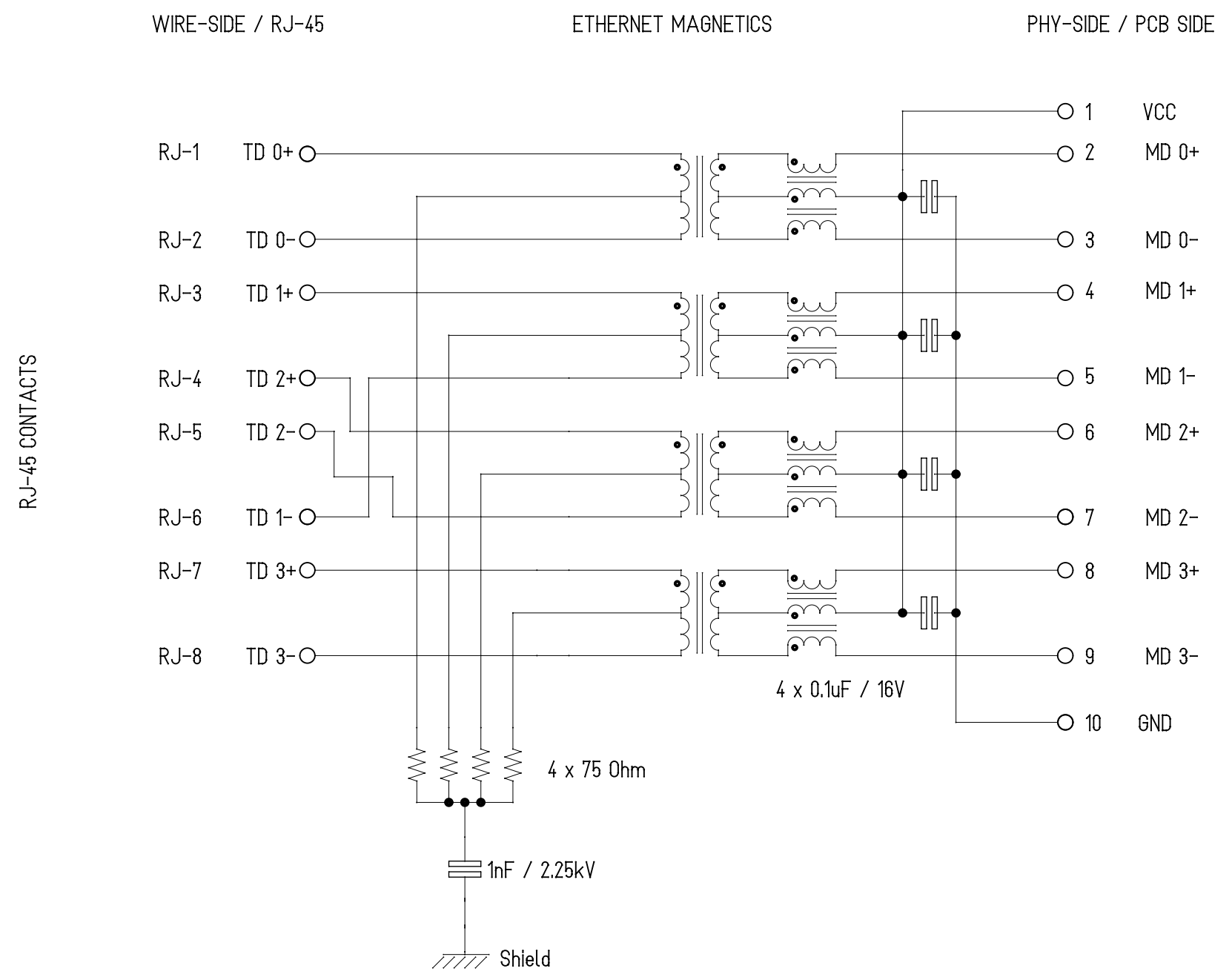

ETHERNET TERMINALS

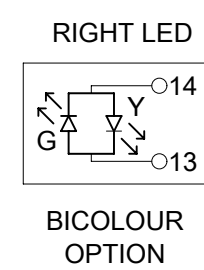
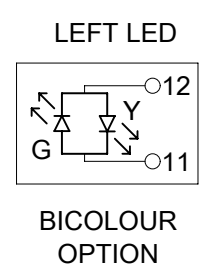

THIS DRAWING CONTAINS INFORMATION THAT IS PROPRIETARY TO MOLEX ELECTRONIC TECHNOLOGIES, LLC AND SHOULD NOT BE USED WITHOUT WRITTEN PERMISSION

DIMENSION UNITS mm	SCALE 1:1	CURRENT REV DESC: UPDATE TITLE BLOCK		molex		
GENERAL TOLERANCES (UNLESS SPECIFIED)		EC NO: 174255				
ANGULAR TOL ± 2.0°		4 PLACES ±	DRWN: DSHEA 2018/03/27	PRODUCT CUSTOMER DRAWING		
3 PLACES ±		3 PLACES ±	CHK'D: SMCGREEVY 2018/04/03	DOCUMENT NUMBER		
2 PLACES ± 0.1		2 PLACES ± 0.1	APPR: DBYRNES 2018/04/04	936260004		
1 PLACE ± 0.2		1 PLACE ± 0.2	INITIAL REVISION:	DOC TYPE	DOC PART	REVISION
0 PLACES ±		0 PLACES ±	DRWN: DSHEA 2017/12/20	PSD	000	B
DRAFT WHERE APPLICABLE MUST REMAIN WITHIN DIMENSIONS	THIRD ANGLE PROJECTION	DRAWING	APPR: DBYRNES 2018/02/01	MATERIAL NUMBER	CUSTOMER	SHEET NUMBER
		A2-SIZE	SERIES 93626	SEE CHART	GENERAL MARKET	3 OF 3