

THIS DRAWING IS UNPUBLISHED
 RELEASED FOR PUBLICATION 2013
 © COPYRIGHT 2013 BY TE CONNECTIVITY. ALL RIGHTS RESERVED.

LOC		DIST		REVISIONS			
P	LTR	DESCRIPTION	DATE	DWN	APVD		
NC		NEW RELEASE PER E.O. P21126	8NOV2011	-	RDR		
A		REVISED PER E.O. P21366	4JUN2012	-	RDR		
A1		REVISED PER ECO-14-002953	29JAN2014	PV	DM		

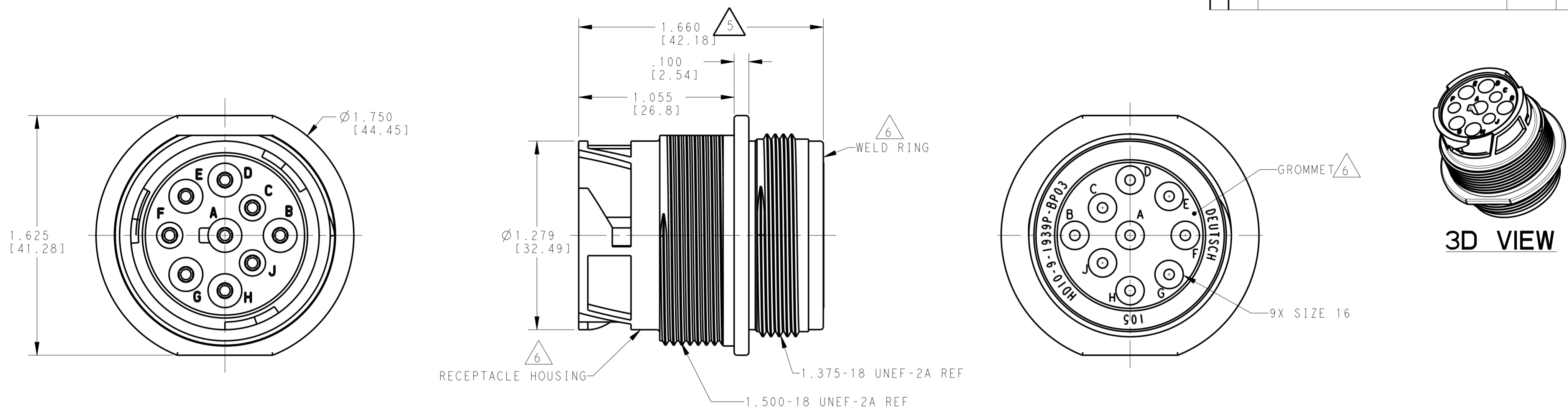

- 8. THIS RECEPTACLE TO BE USED WITH 2411-002-1805 PANEL NUT AND 2414-002-1886 LOCK WASHER. PANEL NUT MOUNTING TORQUE: 45-55 IN. LB. [5.1 - 6.1 N.M.]
- 7. BP03 MODIFICATION: SAE J1939-13, TYPE 2,
- 6 MATERIAL: RECEPTACLE HOUSING AND WELD RING: PA 15%GF (GREEN) GROMMET: SILICONE (RED).
- 5 OVERALL DIMENSION DOES NOT INCLUDE RUBBER GROMMET
- 4. THIS RECEPTACLE MATES WITH FOLLOWING PLUGS (X=SEAL TYPE).
 HD16-9-1939SX-P080
 HD17-9-1939SX-P080
- 3 SEE DRAWING 0425-015-0000 FOR CONTACT AND WIRE PERFORMANCE AND APPLICATION CHARACTERISTICS.
- 2 RECOMMENDED PANEL THICKNESS: .062 [1.57] TO .188 [4.77].
- 1. SEE TABLE FOR USABLE WIRE RANGE AND INSULATION RANGES.

PART NUMBER	SEAL TYPE	CONTACT SIZE	MIN. INSUL. O.D.	MAX. INSUL. O.D.	WIRE RANGE [mm ²]
HD10-9-1939P-BP03	NORMAL	16	.100 [2.54]	.150 [3.81]	14-20 AWG [2.0-.75]
HD10-9-1939PE-BP03	E	16	.053 [1.35]	.120 [3.05]	14-20 AWG [2.0-.50]

NOTES:

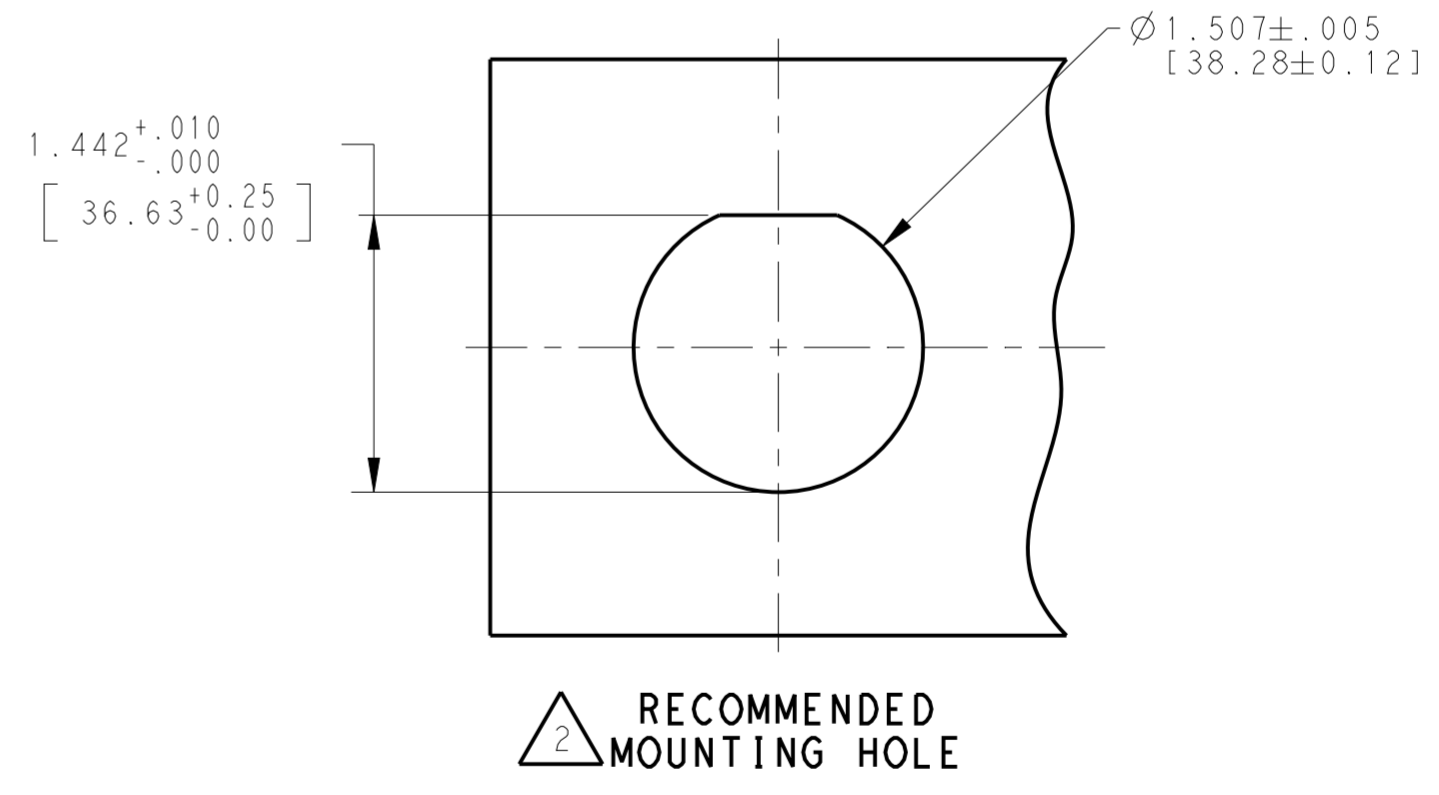

2 RECOMMENDED MOUNTING HOLE

THIS DRAWING IS A CONTROLLED DOCUMENT.

DIMENSIONS: [INCHES [mm]]	TOLERANCES UNLESS OTHERWISE SPECIFIED: 0 PLC ± 1 PLC ± 2 PLC ± 3 PLC ±.025 4 PLC ± ANGLES ±0° 30' 0" FINISH	DWN 9 AUG 2011 I. GRANTCHAROVA CHK 17 SEP 2013 I. GRANTCHAROVA APVD 19 SEP 2013 D. MEYER	NAME RECEPTACLE CONNECTOR ARR. 9-1939 -BP03 MOD HD10 SERIES PANEL MOUNT, D-HOLE
MATERIAL 6	Customer Drawing	WEIGHT 41.91 (g)	SIZE A2 CAGE CODE 00779 DRAWING NO. HD10-9-1939PX-BP03 RESTRICTED TO -
SCALE 1:1		SHEET 1 OF 1 REV A1	

STE TE Connectivity