

Hysteretic Buck High-Brightness LED Driver with High-Side Current Sensing

Features

- Hysteretic Control with High-side Current Sensing
- Wide Input Voltage Range: 4.5V to 40V
- >90% Efficiency
- Typical $\pm 5\%$ LED Current Accuracy
- Up to 2 MHz Switching Frequency
- Adjustable Constant LED Current
- Analog or Pulse-Width Modulation (PWM) Control Signal for PWM Dimming
- Overtemperature Protection
- -40°C to $+125^{\circ}\text{C}$ Operating Temperature Range

Applications

- LED Lighting Applications

General Description

The AT9919 is a PWM controller IC designed to drive high-brightness LEDs using a buck topology. It operates from an input voltage of 4.5 VDC to 40 VDC and employs hysteretic control with a high-side current sense resistor to set the constant output current.

The operating frequency range can be set by selecting the proper inductor. Operation at high switching frequency is possible since the hysteretic control maintains accuracy even at high frequencies. This permits the use of small inductors and capacitors, minimizing space and cost in the overall system.

LED brightness control is achieved with PWM dimming from an analog or PWM input signal. Unique PWM circuitry allows true constant color with a high dimming range. The dimming frequency is programmed using a single external capacitor.

The AT9919 comes in a small, 8-lead DFN package and is qualified for LED lighting applications.

Package Type

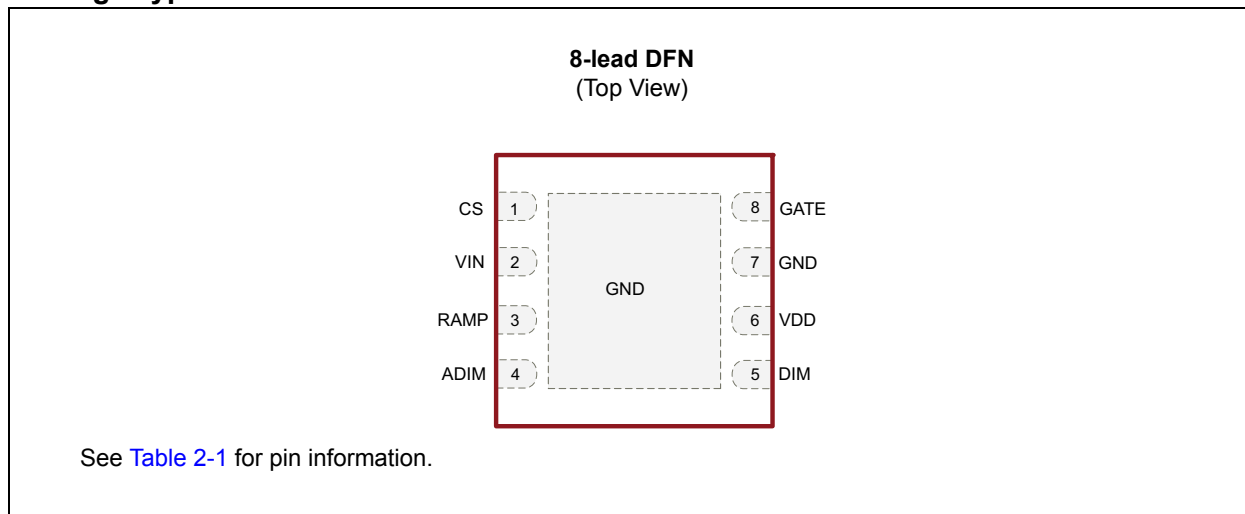

AT9919

Functional Block Diagram

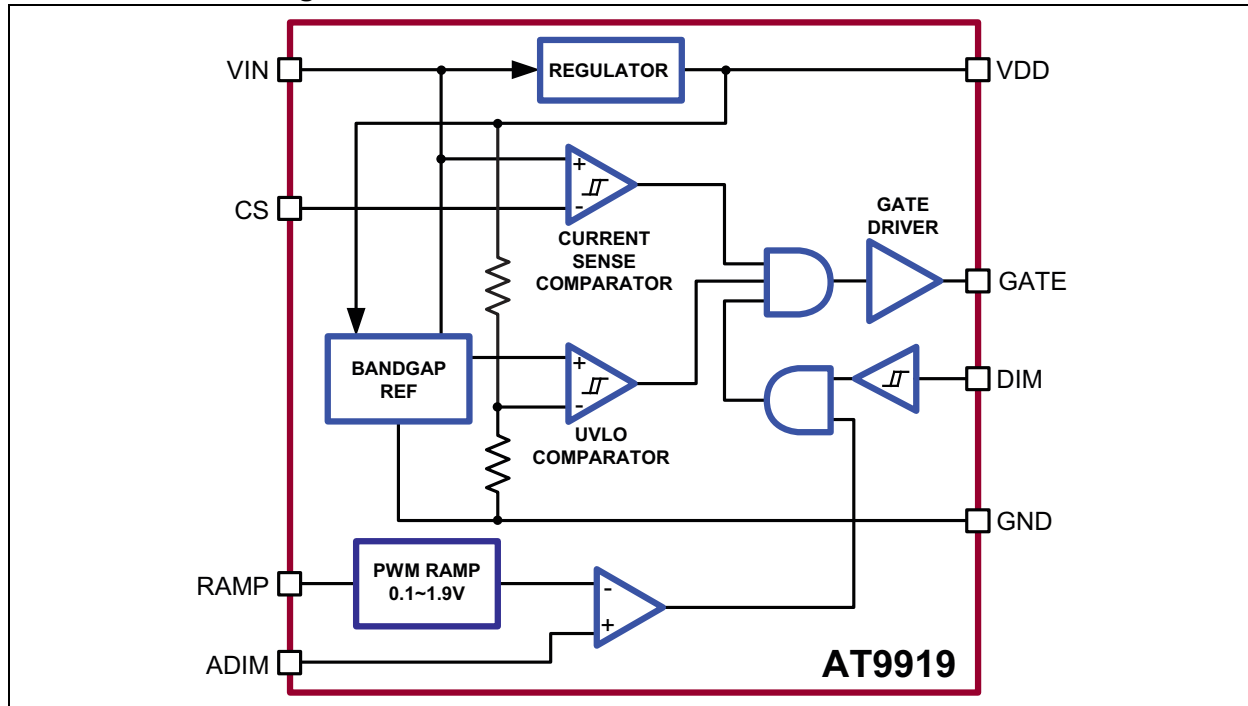

Typical Application Circuit

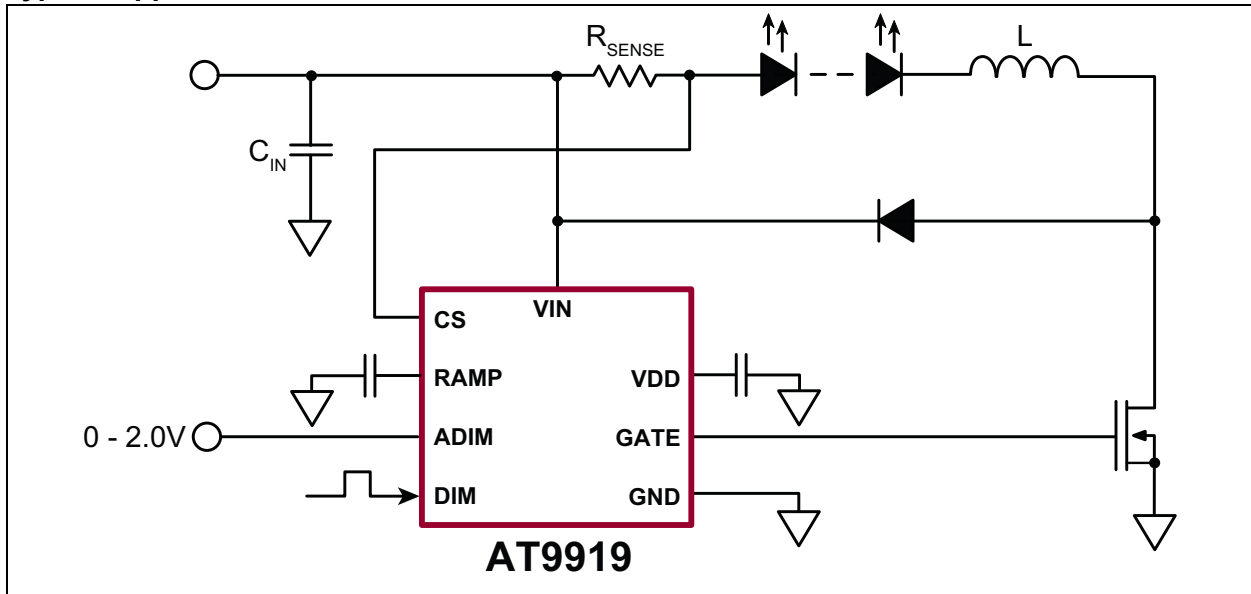

AT9919

1.0 ELECTRICAL CHARACTERISTICS

Absolute Maximum Ratings†

V_{IN} and CS to GND	-0.3V to +45V
V_{DD} , GATE, RAMP, DIM, ADIM to GND.....	-0.3V to +6V
CS to V_{IN}	-1V to +0.3V
Operating Temperature Range.....	-40°C to +125°C
Junction Temperature.....	150°C
Storage Temperature Range	-65°C to 150°C
Continuous Power Dissipation ($T_A = +25^\circ\text{C}$)	1.6W

† **Notice:** Stresses above those listed under “Absolute Maximum Ratings” may cause permanent damage to the device. This is a stress rating only, and functional operation of the device at those or any other conditions above those indicated in the operational sections of this specification is not intended. Exposure to maximum rating conditions for extended periods may affect device reliability.

ELECTRICAL CHARACTERISTICS

Electrical Specifications: $V_{IN} = 12\text{V}$, $V_{DIM} = V_{DD}$, $V_{RAMP} = \text{GND}$, $C_{VDD} = 1\ \mu\text{F}$, $R_{CS} = 0.5\ \Omega$, $T_A = T_J = -40^\circ\text{C}$ to $+125^\circ\text{C}$ (**Note 1**) unless otherwise noted.

Parameter	Sym.	Min.	Typ.	Max.	Unit	Conditions
Input DC Supply Voltage Range	V_{IN}	4.5	—	40	V	DC input voltage
Internally Regulated Voltage	V_{DD}	4.5	—	5.5	V	$V_{IN} = 6\text{V}$ to 40V
Supply Current	I_{IN}	—	—	1.5	mA	GATE open
Shutdown Supply Current	$I_{IN, SDN}$	—	—	900	μA	$\text{DIM} < 0.7\text{V}$
Current Limit	$I_{IN, LIM}$	—	30	—	mA	$V_{IN} = 4.5\text{V}$, $V_{DD} = 0\text{V}$
		—	8	—		$V_{IN} = 4.5\text{V}$, $V_{DD} = 4\text{V}$
Oscillator Frequency	f_{OSC}	—	—	2	MHz	
V_{DD} Undervoltage Lockout Threshold	UVLO	—	—	4.5	V	V_{DD} rising
V_{DD} Undervoltage Lockout Hysteresis	UVLO _{HYST}	—	500	—	mV	V_{DD} falling
SENSE COMPARATOR						
Sense Voltage Threshold High	$V_{CS(HI)}$	198	230	257	mV	$(V_{IN} - V_{CS})$ rising
Sense Voltage Threshold Low	$V_{CS(LO)}$	147	170	195	mV	$(V_{IN} - V_{CS})$ falling
Average Reference Voltage	$V_{CS(AVG)}$	186	200	214	mV	$V_{CS(AVG)} = 0.5V_{CS(HI)} + 0.5V_{CS(LO)}$
Propagation Delay to Output High	t_{DPDH}	—	70	—	ns	Falling edge of $V_{IN} - V_{CS} = V_{RS(LO)} - 70\text{ mV}$
Propagation Delay to Output Low	t_{DPDL}	—	70	—	ns	Rising edge of $V_{IN} - V_{CS} = V_{RS(HI)} + 70\text{ mV}$
Current Sense Input Current	I_{CS}	—	—	1	μA	$V_{IN} - V_{CS} = 200\text{ mV}$
Current Sense Threshold Hysteresis	$V_{CS(HYST)}$	—	56	80	mV	
DIM INPUT						
Pin DIM Input High Voltage	V_{IH}	2.2	—	—	V	
Pin DIM Input Low Voltage	V_{IL}	—	—	0.7	V	
Turn-on Time	t_{ON}	—	100	—	ns	DIM rising edge to $V_{GATE} = 0.5 \times V_{DD}$, $C_{GATE} = 2\text{ nF}$
Turn-off Time	t_{OFF}	—	100	—	ns	DIM falling edge to $V_{GATE} = 0.5 \times V_{DD}$, $C_{GATE} = 2\text{ nF}$

Note 1: Limits obtained by design and characterization.

Note 2: For design guidance only

ELECTRICAL CHARACTERISTICS (CONTINUED)

Electrical Specifications: $V_{IN} = 12V$, $V_{DIM} = V_{DD}$, $V_{RAMP} = GND$, $C_{VDD} = 1 \mu F$, $R_{CS} = 0.5\Omega$, $T_A = T_J = -40^\circ C$ to $+125^\circ C$ (**Note 1**) unless otherwise noted.

Parameter	Sym.	Min.	Typ.	Max.	Unit	Conditions
GATE DRIVER						
GATE Current, Source	I_{GATE}	0.3	0.5	—	A	$V_{GATE} = GND$ (Note 2)
GATE Current, Sink		0.7	1	—	A	$V_{GATE} = V_{DD}$ (Note 2)
GATE Output Rise Time	T_{RISE}	—	40	55	ns	$C_{GATE} = 2 \text{ nF}$
GATE Output Fall Time	T_{FALL}	—	17	25	ns	$C_{GATE} = 2 \text{ nF}$
GATE High Output Voltage	$V_{GATE(HI)}$	$V_{DD} - 0.5$	—	—	V	$I_{GATE} = 10 \text{ mA}$
GATE Low Output Voltage	$V_{GATE(LO)}$	—	—	0.5	V	$I_{GATE} = -10 \text{ mA}$
OVERTEMPERATURE PROTECTION						
Over Temperature Trip Limit	T_{OT}	128	140	—	$^\circ C$	Note 2
Temperature Hysteresis	ΔT_{HYST}	—	60	—	$^\circ C$	Note 2
ANALOG CONTROL OF PWM DIMMING						
Dimming Frequency	f_{RAMP}	130	—	300	Hz	$C_{RAMP} = 47 \text{ nF}$
		550	—	1250		$C_{RAMP} = 10 \text{ nF}$
RAMP Threshold, Low	V_{LOW}	—	0.1	—	V	
RAMP Threshold, High	V_{HIGH}	1.8	—	2.1	V	
ADIM Offset Voltage	V_{OS}	-35	—	+35	mV	

Note 1: Limits obtained by design and characterization.

2: For design guidance only

TEMPERATURE SPECIFICATIONS

Parameter	Sym.	Min.	Typ.	Max.	Unit	Conditions
TEMPERATURE RANGE						
Operating Temperature	T_A	-40	—	+125	$^\circ C$	
Junction Temperature	T_J	—	—	+150	$^\circ C$	
Storage Temperature	T_S	-65	—	+150	$^\circ C$	
PACKAGE THERMAL RESISTANCE						
8-lead DFN	θ_{JA}	—	+37	—	$^\circ C/W$	

AT9919

2.0 PIN DESCRIPTION

The details on the pins of AT9919 are listed on [Table 2-1](#). Refer to [Package Type](#) for the location of pins.

TABLE 2-1: PIN FUNCTION TABLE

Pin Number	Pin Name	Description
1	CS	Current sense input. Senses LED string current.
2	VIN	Input voltage 4.5V to 40V DC
3	RAMP	Analog PWM dimming ramp output
4	ADIM	Analog 0V~2V signal input for analog control of PWM dimming
5	DIM	PWM signal input
6	VDD	Internally regulated supply voltage. Connect a capacitor from VDD to ground.
7	GND	Device ground
8	GATE	Drives GATE of the external MOSFET
TAB	GND	Must be wired to pin 7 on PCB

3.0 APPLICATION INFORMATION

3.1 General Description

The AT9919 is a step-down constant-current high-brightness LED (HB LED) driver. The device operates from a 4.5V to 40V input voltage range and provides the gate drive output to an external N-channel MOSFET. A high-side current sense resistor sets the output current, and a dedicated PWM dimming input (DIM) allows for a wide range of dimming duty ratios. The PWM dimming could also be achieved by applying a DC voltage between 0V and 2V to the analog dimming input (ADIM). In this case, the dimming frequency can be programmed using a single capacitor at the RAMP pin. The high-side current sensing scheme minimizes the number of external components while delivering LED current with a $\pm 8\%$ accuracy, using a 1% sense resistor.

3.2 Undervoltage Lockout (UVLO)

The AT9919 includes a 3.7V UVLO with 500 mV hysteresis. When V_{IN} falls below 3.7V, GATE goes low, turning off the external N-channel MOSFET. GATE goes high once V_{IN} is 4.5V or higher.

3.3 5V Regulator

V_{DD} is the output of a 5V regulator capable of sourcing 8 mA. Bypass V_{DD} to GND with a 1 μ F capacitor.

3.4 DIM Input

The AT9919 allows dimming with a PWM signal at the DIM input. A logic level below 0.7V at DIM forces the GATE_{OUTPUT} low, turning off the LED current. To turn on the LED current, the logic level at DIM must be at least 2.2V.

3.5 ADIM and RAMP Inputs

The PWM dimming scheme can also be implemented by applying an analog control signal to the ADIM pin. If an analog control signal of 0V~2.0V is applied to ADIM, the device compares this analog input to a voltage ramp to pulse width modulate the LED current. Connecting an external capacitor to RAMP programs the PWM dimming ramp frequency. See Equation 3-1.

EQUATION 3-1:

$$f_{PWM} = \frac{1}{C_{RAMP} \times 120k\Omega}$$

The DIM and ADIM inputs can be used simultaneously. In such case, a $f_{PWM(MAX)}$ lower than the frequency of the dimming signal at DIM must be selected. The smaller dimming duty cycle of ADIM and DIM will determine the GATE signal.

When the analog control of PWM dimming feature is not used, RAMP must be wired to GND and ADIM should be connected to V_{DD} .

One possible application of the ADIM feature may include protection of the LED load from overtemperature by connecting an NTC thermistor to ADIM as shown in Figure 3-1.

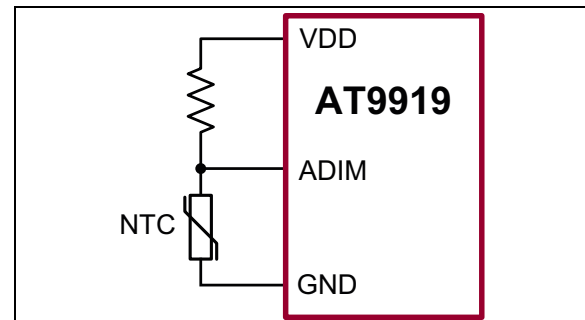

FIGURE 3-1: Overtemperature Protection using ADIM Pin.

3.6 Setting LED Current with the External Resistor (R_{SENSE})

The output current in the LED is determined by the external current sense resistor (R_{SENSE}) connected between V_{IN} and CS. Disregarding the effect of the propagation delays, the sense resistor can be calculated as seen in Equation 3-2.

EQUATION 3-2:

$$R_{SENSE} \approx \left(\frac{1}{2}\right) \times \left(\frac{V_{RS(HD)} + V_{RS(LO)}}{I_{LED}}\right) = \frac{200mV}{I_{LED}}$$

3.7 Selecting Buck Inductor (L)

The AT9919 regulates the LED output current using an input comparator with hysteresis. (See Figure 3-2.) As the current through the inductor ramps up, and the voltage across the sense resistor reaches the upper threshold, the voltage at GATE goes low, turning off the external MOSFET. The MOSFET turns on again when the inductor current ramps down through the freewheeling diode until the voltage across the sense resistor equals the lower threshold.

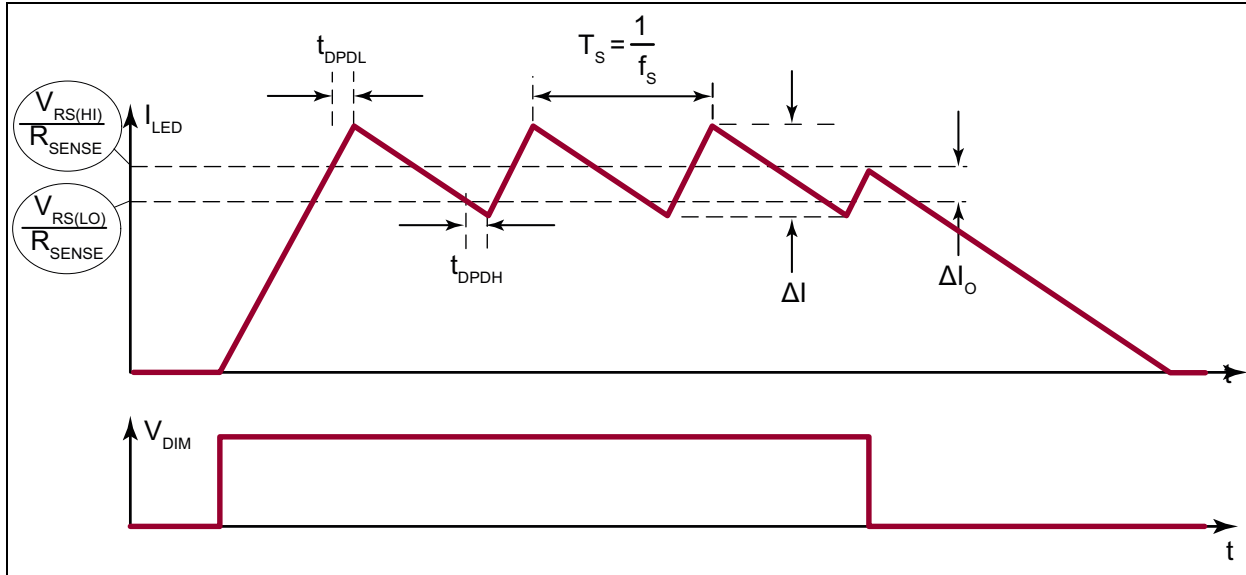

FIGURE 3-2: Inductor Current Waveform.

Equation 3-3 shows how to determine the inductor value for a desired operating frequency (f_s).

EQUATION 3-3:

$$L = \frac{(V_{IN} - V_{OUT}) \times V_{OUT}}{f_s V_{IN} \Delta I_O} - \frac{(V_{IN} - V_{OUT}) \times t_{DPDL}}{\Delta I_O} - \frac{V_{OUT} t_{DPDH}}{\Delta I_O}$$

Where:

$$\Delta I_O = \frac{V_{RS(HI)} - V_{RS(LO)}}{R_{SENSE}}$$

and t_{DPDL} and t_{DPDH} are the propagation delays.
Note that the current ripple (ΔI) in the inductor (L) is greater than ΔI_O .

The current ripple in the inductor (L) can be calculated with Equation 3-4.

EQUATION 3-4:

$$\Delta I = \Delta I_O + \frac{(V_{IN} - V_{OUT}) \times t_{DPDL}}{L} + \frac{V_{OUT} t_{DPDH}}{L}$$

For proper inductor selection, note that the maximum switching frequency occurs at the highest V_{IN} and $V_{OUT} = V_{IN}/2$.

3.8 MOSFET Selection

MOSFET selection is based on the maximum input operating voltage V_{IN} , output current I_{LED} and operating switching frequency. Choose a MOSFET that has a higher breakdown voltage than the maximum operation voltage, low $R_{DS(ON)}$ and low total charge for

better efficiency. MOSFET threshold voltage must be adequate when operated at the low end of the input voltage operating range.

3.9 Freewheeling Diode Selection

The forward voltage of the freewheeling diode should be as low as possible for better efficiency. A Schottky diode is a good choice as long as the breakdown voltage is high enough to withstand the maximum operating voltage. The forward current rating of the diode must be at least equal to the maximum LED current.

3.10 LED Current Ripple

The LED current ripple is equal to the inductor current ripple. In cases when a lower LED current ripple is needed, a capacitor can be placed across the LED terminals.

3.11 PCB Layout Guidelines

Careful PCB layout is critical to achieving low switching losses and stable operation. Use a multilayer board whenever possible for better noise immunity. Minimize ground noise by connecting high-current ground returns, the input bypass capacitor ground lead and the output filter ground lead to a single point (star ground configuration). The fast di/dt loop is composed of the input capacitor C_{IN} , the freewheeling diode and the MOSFET. To minimize noise interaction, this loop area should be as small as possible. Place R_{SENSE} as close as possible to the input filter and V_{IN} . For better noise immunity, a Kelvin connection is strongly recommended between CS and R_{SENSE} . Connect the exposed tab of the IC to a large area ground plane for improved power dissipation.

AT9919

4.0 PACKAGING INFORMATION

4.1 Package Marking Information

8-lead DFN

Example

XXXX
YYWW
●NNN

9919
1612
●373

Legend:	XX...X	Product Code or Customer-specific information
	Y	Year code (last digit of calendar year)
	YY	Year code (last 2 digits of calendar year)
	WW	Week code (week of January 1 is week '01')
	NNN	Alphanumeric traceability code
	(e3)	Pb-free JEDEC® designator for Matte Tin (Sn)
	*	This package is Pb-free. The Pb-free JEDEC designator (e3) can be found on the outer packaging for this package.
Note:	In the event the full Microchip part number cannot be marked on one line, it will be carried over to the next line, thus limiting the number of available characters for product code or customer-specific information. Package may or not include the corporate logo.	

8-Lead DFN Package Outline (K7) 3.00x3.00mm body, 0.80mm height (max), 0.65mm pitch

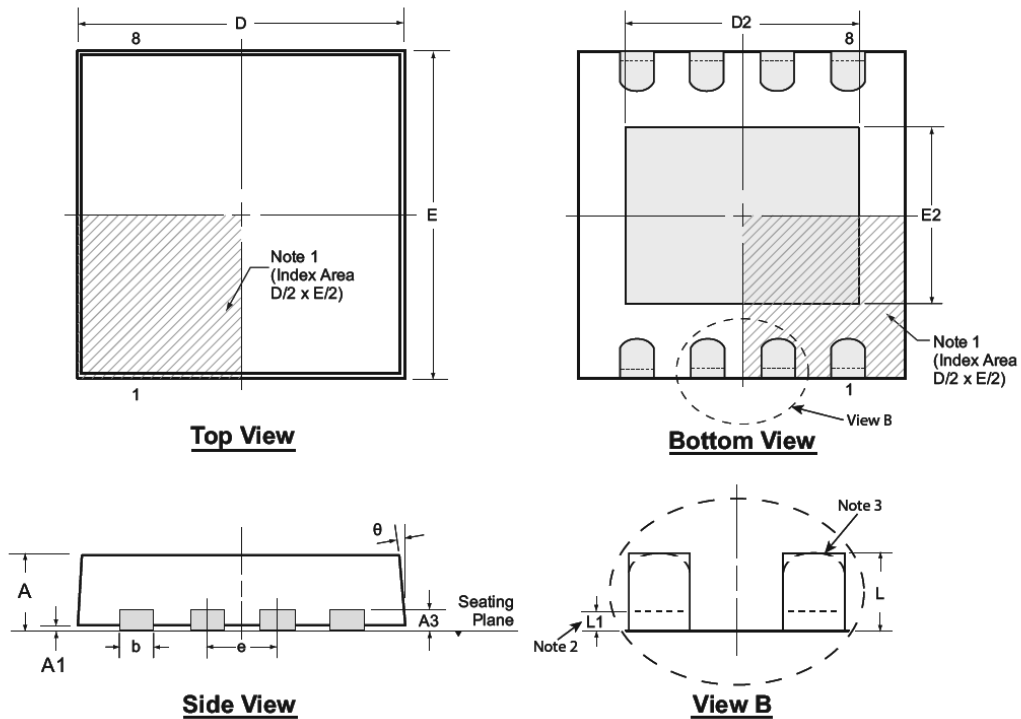

Note: For the most current package drawings, see the Microchip Packaging Specification at www.microchip.com/packaging.

Notes:

1. A Pin 1 identifier must be located in the index area indicated. The Pin 1 identifier can be: a molded mark/identifier, an embedded metal marker, or a printed indicator.
2. Depending on the method of manufacturing, a maximum of 0.15mm pullback (L_1) may be present.
3. The inner tip of the lead may be either rounded or square.

Symbol	A	A1	A3	b	D	D2	E	E2	e	L	L1	θ	
Dimension (mm)	MIN	0.70	0.00	0.20 REF	0.25	2.85*	1.60	2.85*	1.35	0.65 BSC	0.30	0.00*	0°
	NOM	0.75	0.02		0.30	3.00	-	3.00	-		0.40	-	-
	MAX	0.80	0.05		0.35	3.15*	2.50	3.15*	1.75		0.50	0.15	14°

JEDEC Registration MO-229, Variation WEEC-2, Issue C, Aug. 2003.

* This dimension is not specified in the JEDEC drawing.

Drawings not to scale.

AT9919

NOTES:

APPENDIX A: REVISION HISTORY

Revision A (October 2016)

- Converted Supertex Doc# DSFP-AT9919 to Microchip DS20005595A.
- Changed packaging quantity of 8-lead DFN from 3000/Reel to 3300/Reel.
- Made minor text changes throughout the document.

AT9919

PRODUCT IDENTIFICATION SYSTEM

To order or obtain information, e.g., on pricing or delivery, contact your local Microchip representative or sales office.

<u>PART NO.</u>	<u>XX</u>	-	<u>X</u>	-	<u>X</u>
Device	Package Options		Environmental		Media Type
Device:	AT9919	=	Hysteretic Buck High-Brightness LED Driver with High-Side Current Sensing		
Package:	K7	=	8-lead (3x3) DFN		
Environmental:	G	=	Lead (Pb)-free/RoHS-compliant Package		
Media Type:	(blank)	=	3300/Reel for a K7 Package		

Example:

a) AT9919K7-G: Hysteretic Buck High-Brightness LED Driver with High-Side Current Sensing, 8-lead (3x3) DFN Package, 3300/Reel

Note the following details of the code protection feature on Microchip devices:

- Microchip products meet the specification contained in their particular Microchip Data Sheet.
- Microchip believes that its family of products is one of the most secure families of its kind on the market today, when used in the intended manner and under normal conditions.
- There are dishonest and possibly illegal methods used to breach the code protection feature. All of these methods, to our knowledge, require using the Microchip products in a manner outside the operating specifications contained in Microchip's Data Sheets. Most likely, the person doing so is engaged in theft of intellectual property.
- Microchip is willing to work with the customer who is concerned about the integrity of their code.
- Neither Microchip nor any other semiconductor manufacturer can guarantee the security of their code. Code protection does not mean that we are guaranteeing the product as “unbreakable.”

Code protection is constantly evolving. We at Microchip are committed to continuously improving the code protection features of our products. Attempts to break Microchip's code protection feature may be a violation of the Digital Millennium Copyright Act. If such acts allow unauthorized access to your software or other copyrighted work, you may have a right to sue for relief under that Act.

Information contained in this publication regarding device applications and the like is provided only for your convenience and may be superseded by updates. It is your responsibility to ensure that your application meets with your specifications. MICROCHIP MAKES NO REPRESENTATIONS OR WARRANTIES OF ANY KIND WHETHER EXPRESS OR IMPLIED, WRITTEN OR ORAL, STATUTORY OR OTHERWISE, RELATED TO THE INFORMATION, INCLUDING BUT NOT LIMITED TO ITS CONDITION, QUALITY, PERFORMANCE, MERCHANTABILITY OR FITNESS FOR PURPOSE. Microchip disclaims all liability arising from this information and its use. Use of Microchip devices in life support and/or safety applications is entirely at the buyer's risk, and the buyer agrees to defend, indemnify and hold harmless Microchip from any and all damages, claims, suits, or expenses resulting from such use. No licenses are conveyed, implicitly or otherwise, under any Microchip intellectual property rights unless otherwise stated.

Microchip received ISO/TS-16949:2009 certification for its worldwide headquarters, design and wafer fabrication facilities in Chandler and Tempe, Arizona; Gresham, Oregon and design centers in California and India. The Company's quality system processes and procedures are for its PIC® MCUs and dsPIC® DSCs, KEELOQ® code hopping devices, Serial EEPROMs, microperipherals, nonvolatile memory and analog products. In addition, Microchip's quality system for the design and manufacture of development systems is ISO 9001:2000 certified.

**QUALITY MANAGEMENT SYSTEM
CERTIFIED BY DNV
= ISO/TS 16949 =**

Trademarks

The Microchip name and logo, the Microchip logo, AnyRate, dsPIC, FlashFlex, flexPWR, Heldo, JukeBlox, KeeLoq, KeeLoq logo, Klear, LANCheck, LINK MD, MediaLB, MOST, MOST logo, MPLAB, OptoLyzer, PIC, PICSTART, PIC32 logo, RightTouch, SpyNIC, SST, SST Logo, SuperFlash and UNI/O are registered trademarks of Microchip Technology Incorporated in the U.S.A. and other countries.

ClockWorks, The Embedded Control Solutions Company, ETHERSYNCH, Hyper Speed Control, HyperLight Load, IntelliMOS, mTouch, Precision Edge, and QUIET-WIRE are registered trademarks of Microchip Technology Incorporated in the U.S.A.

Analog-for-the-Digital Age, Any Capacitor, AnyIn, AnyOut, BodyCom, chipKIT, chipKIT logo, CodeGuard, dsPICDEM, dsPICDEM.net, Dynamic Average Matching, DAM, ECAN, EtherGREEN, In-Circuit Serial Programming, ICSP, Inter-Chip Connectivity, JitterBlocker, KlearNet, KlearNet logo, MiWi, motorBench, MPASM, MPF, MPLAB Certified logo, MPLIB, MPLINK, MultiTRAK, NetDetach, Omniscient Code Generation, PICDEM, PICDEM.net, PICkit, PICtail, PureSilicon, RightTouch logo, REAL ICE, Ripple Blocker, Serial Quad I/O, SQL, SuperSwitcher, SuperSwitcher II, Total Endurance, TSHARC, USBCheck, VariSense, ViewSpan, WiperLock, Wireless DNA, and ZENA are trademarks of Microchip Technology Incorporated in the U.S.A. and other countries.

SQTP is a service mark of Microchip Technology Incorporated in the U.S.A.

Silicon Storage Technology is a registered trademark of Microchip Technology Inc. in other countries.

GestIC is a registered trademarks of Microchip Technology Germany II GmbH & Co. KG, a subsidiary of Microchip Technology Inc., in other countries.

All other trademarks mentioned herein are property of their respective companies.

© 2016, Microchip Technology Incorporated, Printed in the U.S.A., All Rights Reserved.

ISBN: 978-1-5224-0992-2



MICROCHIP

Worldwide Sales and Service

AMERICAS

Corporate Office
2355 West Chandler Blvd.
Chandler, AZ 85224-6199
Tel: 480-792-7200
Fax: 480-792-7277
Technical Support:
<http://www.microchip.com/support>
Web Address:
www.microchip.com

Atlanta
Duluth, GA
Tel: 678-957-9614
Fax: 678-957-1455

Austin, TX
Tel: 512-257-3370

Boston
Westborough, MA
Tel: 774-760-0087
Fax: 774-760-0088

Chicago
Itasca, IL
Tel: 630-285-0071
Fax: 630-285-0075

Cleveland
Independence, OH
Tel: 216-447-0464
Fax: 216-447-0643

Dallas
Addison, TX
Tel: 972-818-7423
Fax: 972-818-2924

Detroit
Novi, MI
Tel: 248-848-4000

Houston, TX
Tel: 281-894-5983

Indianapolis
Noblesville, IN
Tel: 317-773-8323
Fax: 317-773-5453

Los Angeles
Mission Viejo, CA
Tel: 949-462-9523
Fax: 949-462-9608

New York, NY
Tel: 631-435-6000

San Jose, CA
Tel: 408-735-9110

Canada - Toronto
Tel: 905-695-1980
Fax: 905-695-2078

ASIA/PACIFIC

Asia Pacific Office
Suites 3707-14, 37th Floor
Tower 6, The Gateway
Harbour City, Kowloon

Hong Kong
Tel: 852-2943-5100
Fax: 852-2401-3431

Australia - Sydney
Tel: 61-2-9868-6733
Fax: 61-2-9868-6755

China - Beijing
Tel: 86-10-8569-7000
Fax: 86-10-8528-2104

China - Chengdu
Tel: 86-28-8665-5511
Fax: 86-28-8665-7889

China - Chongqing
Tel: 86-23-8980-9588
Fax: 86-23-8980-9500

China - Dongguan
Tel: 86-769-8702-9880

China - Guangzhou
Tel: 86-20-8755-8029

China - Hangzhou
Tel: 86-571-8792-8115
Fax: 86-571-8792-8116

China - Hong Kong SAR
Tel: 852-2943-5100
Fax: 852-2401-3431

China - Nanjing
Tel: 86-25-8473-2460
Fax: 86-25-8473-2470

China - Qingdao
Tel: 86-532-8502-7355
Fax: 86-532-8502-7205

China - Shanghai
Tel: 86-21-5407-5533
Fax: 86-21-5407-5066

China - Shenyang
Tel: 86-24-2334-2829
Fax: 86-24-2334-2393

China - Shenzhen
Tel: 86-755-8864-2200
Fax: 86-755-8203-1760

China - Wuhan
Tel: 86-27-5980-5300
Fax: 86-27-5980-5118

China - Xian
Tel: 86-29-8833-7252
Fax: 86-29-8833-7256

ASIA/PACIFIC

China - Xiamen
Tel: 86-592-2388138
Fax: 86-592-2388130

China - Zhuhai
Tel: 86-756-3210040
Fax: 86-756-3210049

India - Bangalore
Tel: 91-80-3090-4444
Fax: 91-80-3090-4123

India - New Delhi
Tel: 91-11-4160-8631
Fax: 91-11-4160-8632

India - Pune
Tel: 91-20-3019-1500

Japan - Osaka
Tel: 81-6-6152-7160
Fax: 81-6-6152-9310

Japan - Tokyo
Tel: 81-3-6880-3770
Fax: 81-3-6880-3771

Korea - Daegu
Tel: 82-53-744-4301
Fax: 82-53-744-4302

Korea - Seoul
Tel: 82-2-554-7200
Fax: 82-2-558-5932 or
82-2-558-5934

Malaysia - Kuala Lumpur
Tel: 60-3-6201-9857
Fax: 60-3-6201-9859

Malaysia - Penang
Tel: 60-4-227-8870
Fax: 60-4-227-4068

Philippines - Manila
Tel: 63-2-634-9065
Fax: 63-2-634-9069

Singapore
Tel: 65-6334-8870
Fax: 65-6334-8850

Taiwan - Hsin Chu
Tel: 886-3-5778-366
Fax: 886-3-5770-955

Taiwan - Kaohsiung
Tel: 886-7-213-7828

Taiwan - Taipei
Tel: 886-2-2508-8600
Fax: 886-2-2508-0102

Thailand - Bangkok
Tel: 66-2-694-1351
Fax: 66-2-694-1350

EUROPE

Austria - Wels
Tel: 43-7242-2244-39
Fax: 43-7242-2244-393

Denmark - Copenhagen
Tel: 45-4450-2828
Fax: 45-4485-2829

France - Paris
Tel: 33-1-69-53-63-20
Fax: 33-1-69-30-90-79

Germany - Dusseldorf
Tel: 49-2129-3766400

Germany - Karlsruhe
Tel: 49-721-625370

Germany - Munich
Tel: 49-89-627-144-0
Fax: 49-89-627-144-44

Italy - Milan
Tel: 39-0331-742611
Fax: 39-0331-466781

Italy - Venice
Tel: 39-049-7625286

Netherlands - Drunen
Tel: 31-416-690399
Fax: 31-416-690340

Poland - Warsaw
Tel: 48-22-3325737

Spain - Madrid
Tel: 34-91-708-08-90
Fax: 34-91-708-08-91

Sweden - Stockholm
Tel: 46-8-5090-4654

UK - Wokingham
Tel: 44-118-921-5800
Fax: 44-118-921-5820

06/23/16