

PART NAME: KNOB SCALE: 1:1 DATE: 8/19/85 DR. BY HD

THIS DRAWING IS THE PROPERTY OF DAVIES MOLDING COMPANY, IS SUBMITTED SOLELY AS A DESIGN OR ENGINEERING PROJECT.
WE ACCEPT NO RESPONSIBILITY WHATSOEVER FOR THE PRACTICAL APPLICATION OF THE PIECES MADE TO THIS DESIGN.



DESIGNERS & MANUFACTURERS
OF KNOBS, HANDLES, CASES &
CUSTOM PLASTIC COMPONENTS

P/N 3088-B

M NO. # 30

| | |
|------------|--------|
| CAVITY | 3088 |
| CORE | 3088 |
| BUSHING | 3088 |
| EJECT. PIN | 3088 |
| PIN | 3088-3 |
| INSERT | I0212 |

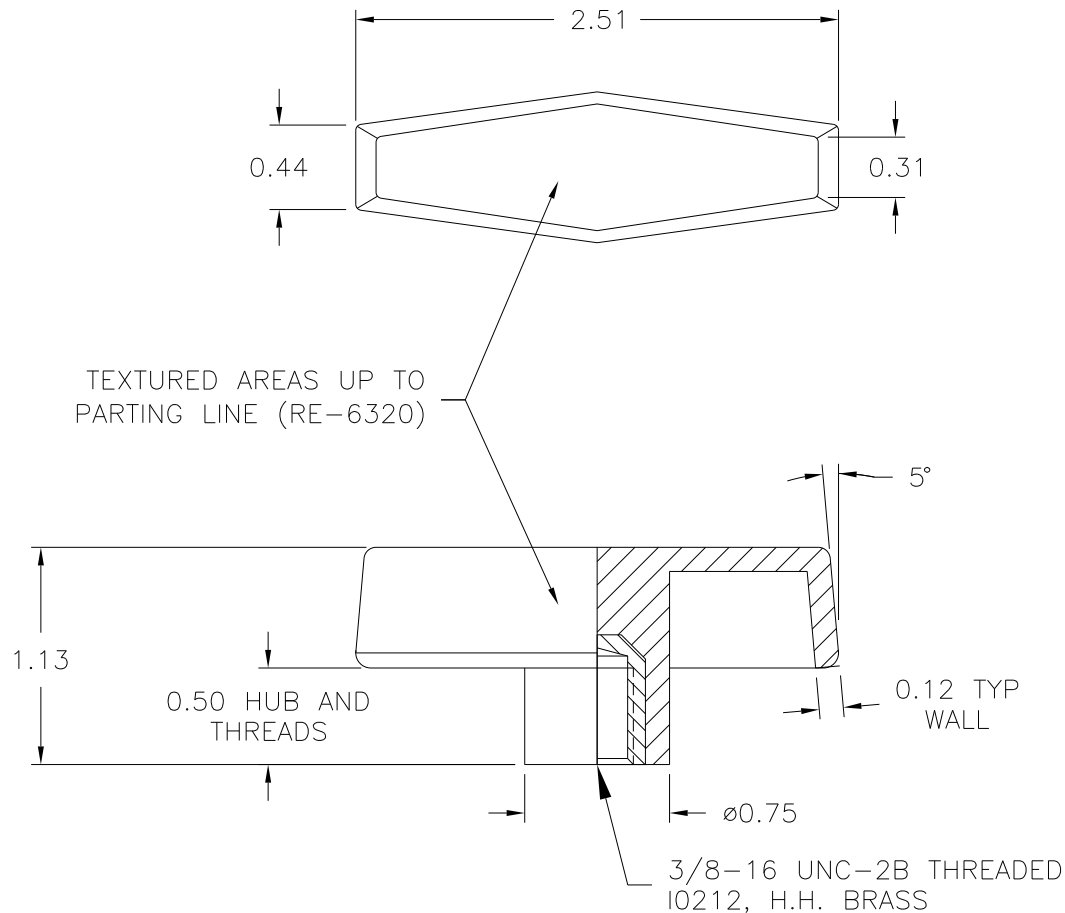

Ⓑ
MATERIAL: POLYPROPYLENE (CLD) Ⓒ
COLOR: BLACK

| | |
|---|----------------------------------|
| TOLERANCES: UNLESS OTHERWISE SPECIFIED | DO NOT SCALE DRAWING |
| DECIMALS: X.XXX ± .005 X.XX ± .015 | MM: X.XX ± 0.15MM X.X ± 0.4MM |
| FRACTIONS ± 1/64 | ANG. ± 1° |

| | | | |
|---|-----------------|----|----------|
| C | ADDED MAT. CODE | DS | 1/26/07 |
| - | REDRAWN | TL | 11/11/99 |
| B | WAS NYLON 6/6 | HD | 12/2/96 |
| - | CAD REDRAW | HD | 11/2/92 |
| A | WAS I1500 | HD | 8/7/92 |

CHANGES