

10115091 - X 0 E - X X X L F

8-COLUMN DIFFERENTIAL SIGNAL

LEAD-FREE DESIGNATION ONLY WITH APPLICABLE PLATING CODES

LETTER	PLATING (SEE NOTE 6)	
	APPLICATION	TYPE (REFERENCE)
B	TELCORDIA CO	0.76um GOLD or GXT
C	TELCORDIA UE	1.27um GOLD
D	TELCORDIA CO	0.76um GOLD or GXT, LEAD-FREE
E	TELCORDIA UE	1.27um GOLD, LEAD-FREE

NUMBER	GUIDE PIN STYLE (SEE NOTE 8)
0	STANDARD GUIDE PIN, MACHINED
1	STANDARD GUIDE PIN, ROLLED

NUMBER	CONTACT MATING WIPE LENGTH		COMPLIANT TAIL TYPE (SEE NOTE 9)
	SIGNAL	GROUND	
1	2 MM	4 MM	0.55 (0.0217") DRILL
2	3 MM	4 MM	0.55 (0.0217") DRILL
3	2 MM	4 MM	0.45 MICRO (0.0177") DRILL
4	3 MM	4 MM	0.45 MICRO (0.0177") DRILL
5	2 MM	3 MM	0.55 (0.0217") DRILL
6	3 MM	3 MM	0.55 (0.0217") DRILL
7	2 MM	3 MM	0.45 MICRO (0.0177") DRILL
8	3 MM	3 MM	0.45 MICRO (0.0177") DRILL

FOR CUSTOM-LOADED MODULES, SEE INDIVIDUAL CUSTOM DRAWINGS WITH THE DRAWING-NUMBER FORMAT OF 10115091-XXXX, WHERE: "X" DENOTES MODULE TYPE PER CHART ON THIS SHEET "YYYY" IS A SEQUENTIAL NUMBER BEGINNING WITH "0001".

MODULE DESCRIPTION	LETTER DESIGNATION REPRESENTED IN DASH NUMBER										BASE MODULE
LEFT POLARIZING GUIDANCE MODULE (SEE SHEET 6)	N	J	A	B	C	D	E	F	G	H	
	NO KEY NO GUIDE PIN										
RIGHT POLARIZING GUIDANCE MODULE (SEE SHEET 7)	Z	Y	P	Q	R	S	T	U	V	W	
	NO KEY NO GUIDE PIN										
OPEN MODULE (TWO WALL) (SEE SHEET 2)	0 (ZERO)										
LEFT WALL MODULE (SEE SHEET 3)	L										
RIGHT WALL MODULE (SEE SHEET 4)	M										
FOUR WALL MODULE (SEE SHEET 5)	1 (ONE)										

	UNGROUNDED	GROUNDED
FHS	Ø2.35-Ø2.55	Ø2.35-Ø2.55
PAD	N/A	Ø5.50
PLATED	NO	YES
DRILL (mm)	2.44mm	2.58mm
DRILL (in)	0.096"	0.1015"

SCREW P/N	DESCRIPTION	BOARD THICKNESS
10091790-002LF	#2-56 X 0.375" LG. PHILIPS PANHEAD W/SQ CONICAL WASHER	1.60-5.00mm
10091790-003LF	#2-56 X 0.375" LG. PHILIPS PANHEAD W/SQ CONICAL WASHER	5.00-10.00mm

spec ref	tolerance std	TOLERANCES UNLESS OTHERWISE SPECIFIED		
	ISO 406	linear	0.X	±0.3
	ISO 1101		0.XX	±0.10
			0.XXX	±0.05
	ISO 1302	angular	0°	±2°

dr Collins Lu	2011/07/27	projection	mm	size	A2	scale	1:1
eng Sandar Soe	2016/03/07		←	ecn no	ELX-S-17624-1		
chr -	-			rel level	Released		
appr Chen-Hong Tan	2016/03/17	product family	-	cat. no.	Product - Customer Drw	sheet 1 of 8	rev E

Amphenol FCI

© 2016 AFCI

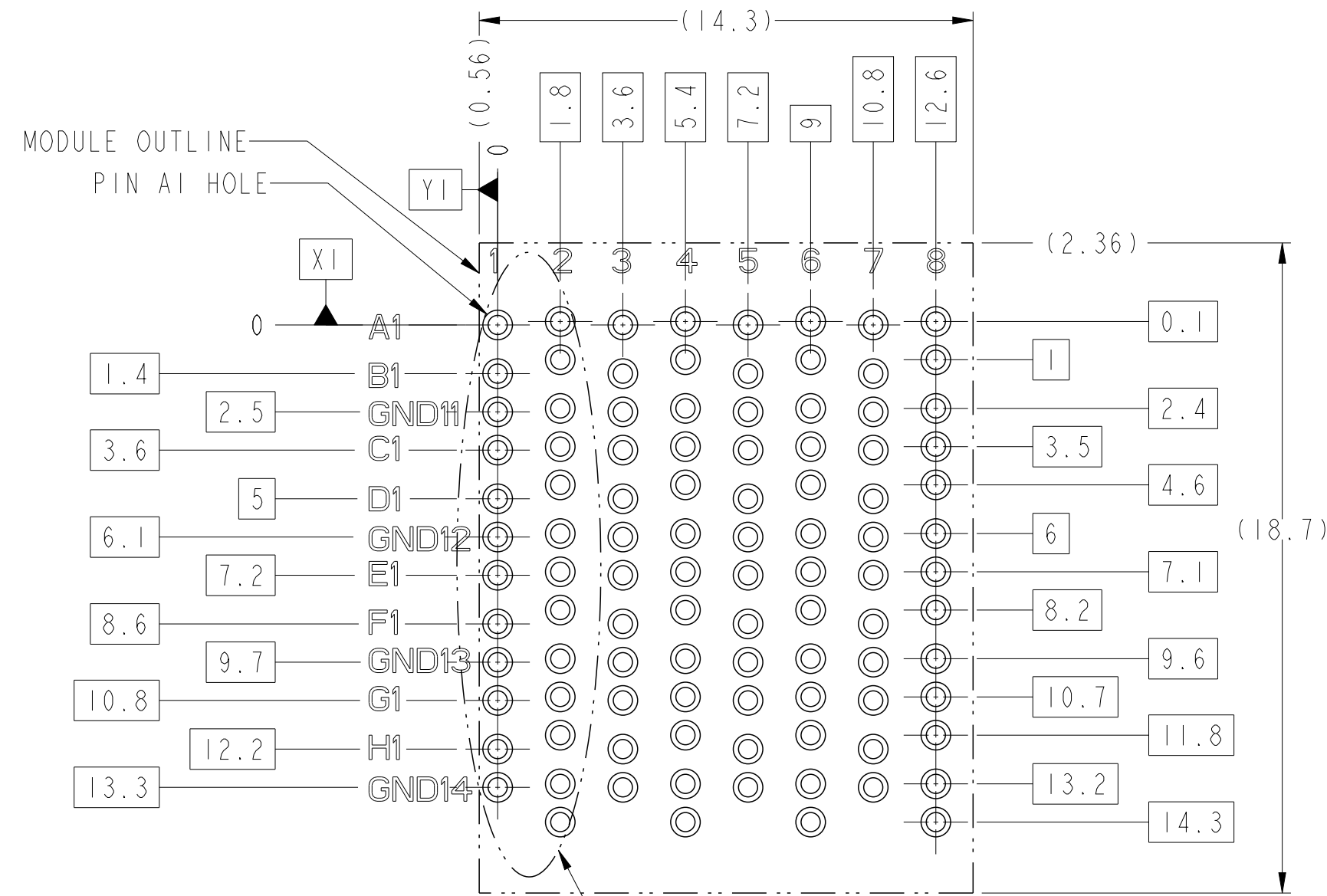
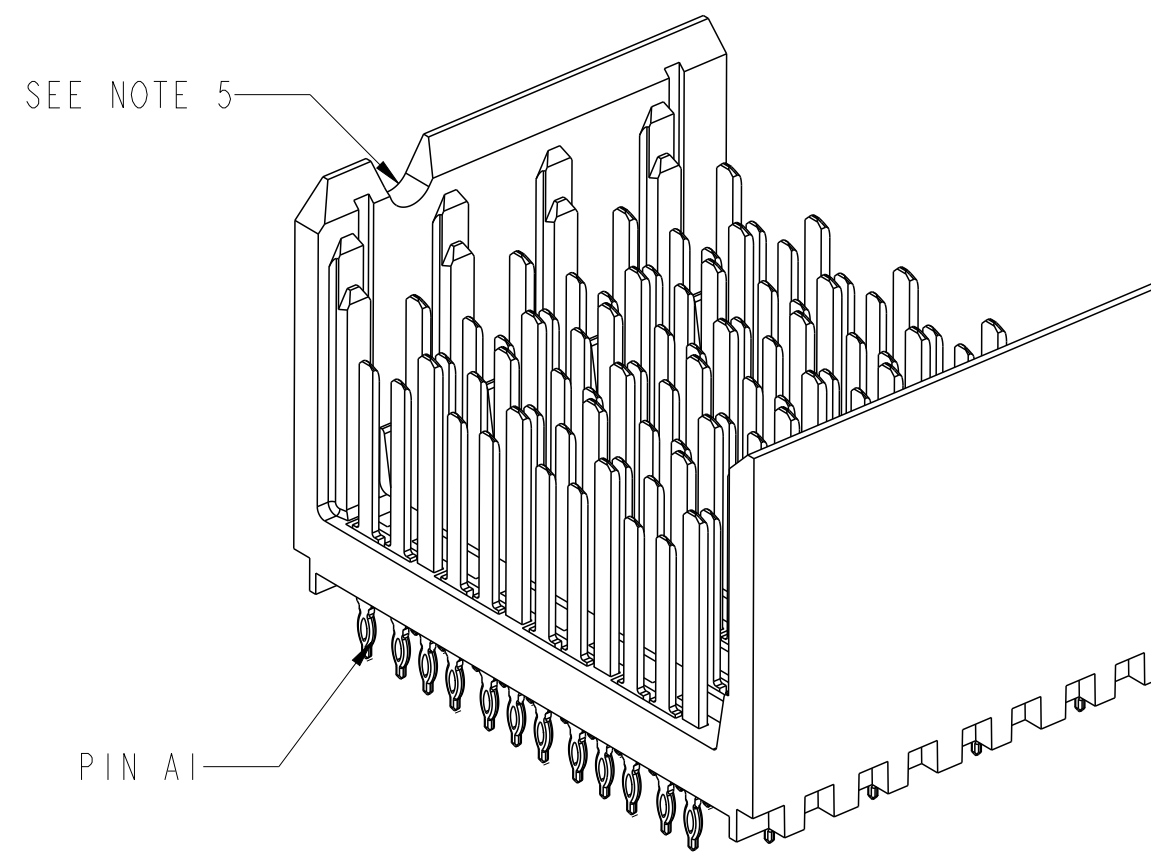
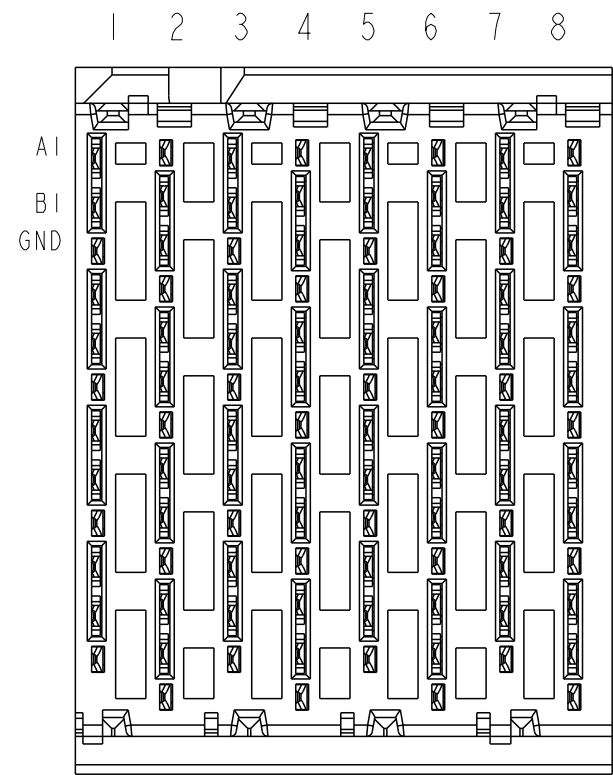

OPEN WALL MODULE

SEE DETAIL A
On Sheet 8 For Details

BP HOLE PATTERN COMPONENT SIDE
OPEN WALL MODULE BACKPLANE FOOTPRINT

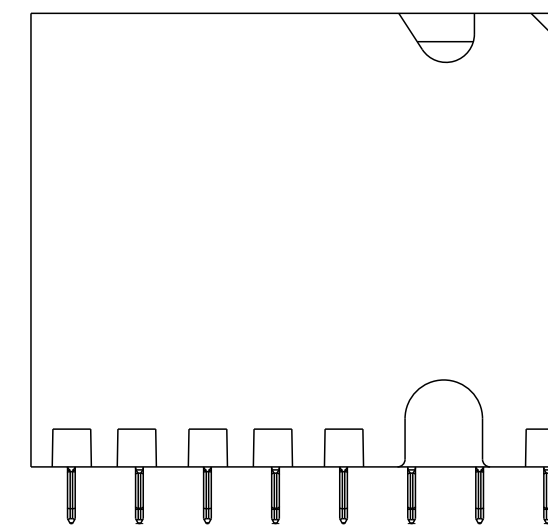
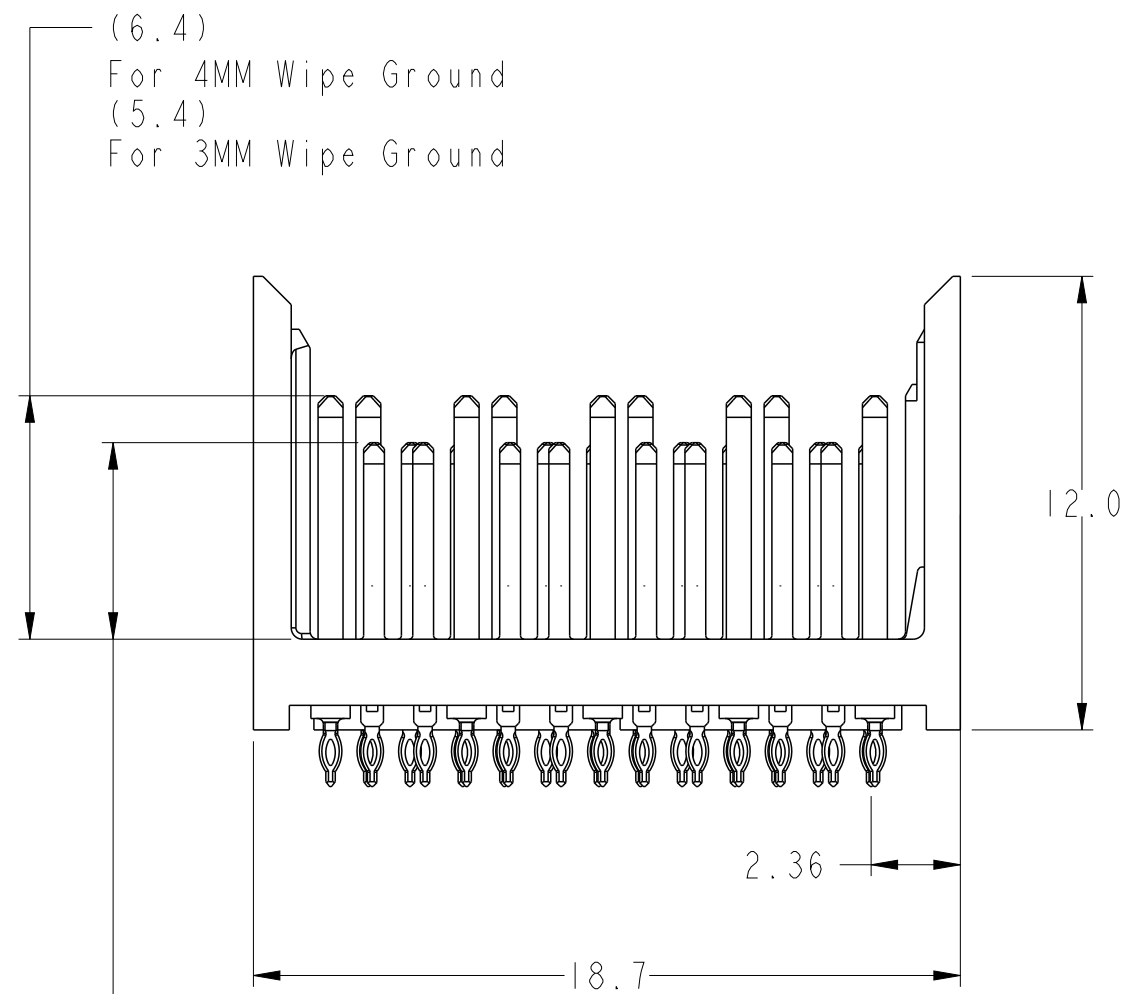
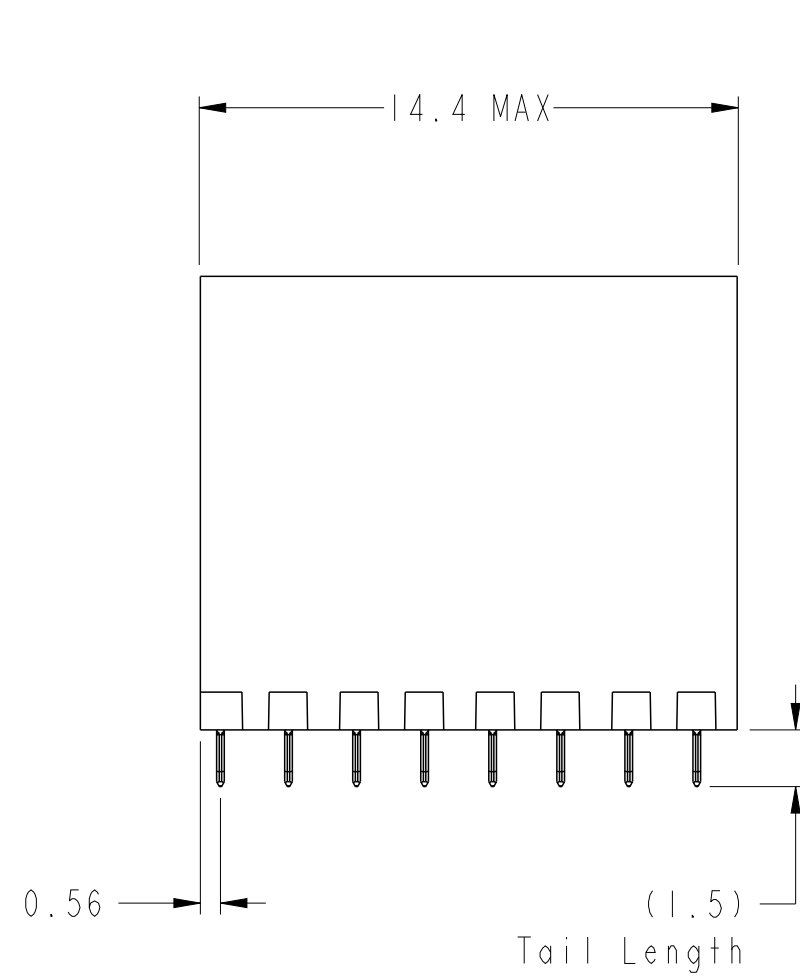

spec ref	-	dr	Collins Lu	2011/07/27	projection	mm	size	A2	scale	1:1			
tolerance std	ISO 406 ISO 1101	eng	Sandar Soe	2016/03/07		mm	ecn no	ELX-S-17624-1	rel level	Released			
TOLERANCES UNLESS OTHERWISE SPECIFIED		chr	-	appr							Chen-Hong Tan	2016/03/17	product family
surface	ISO 1302	linear	0.X	±0.3			title	MODULE ASSEMBLY, XCEDE HD		dwg no	10115091	rev	E
		angular	0°	±2°	www.fci.com	cat. no.	-	Product - Customer Drw	sheet 2 of 8				

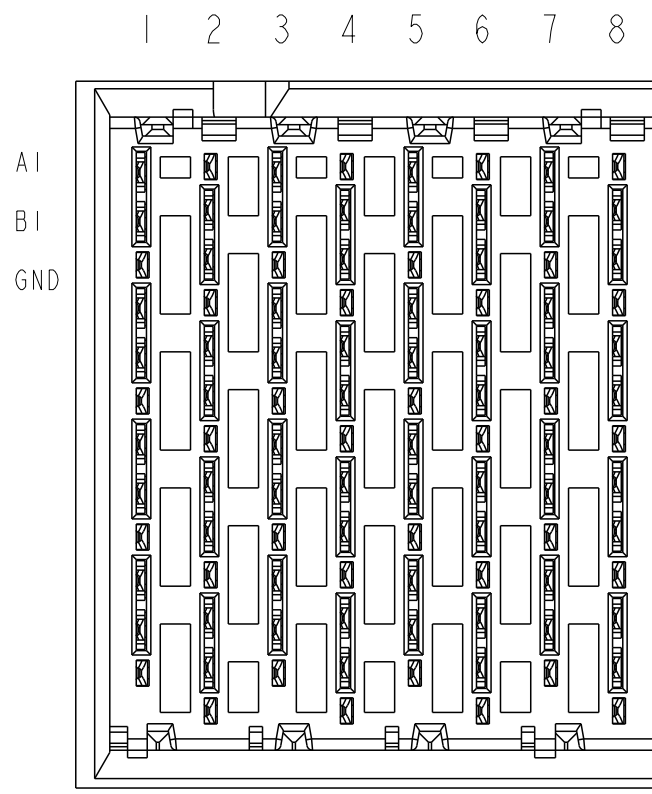

LEFT WALL MODULE

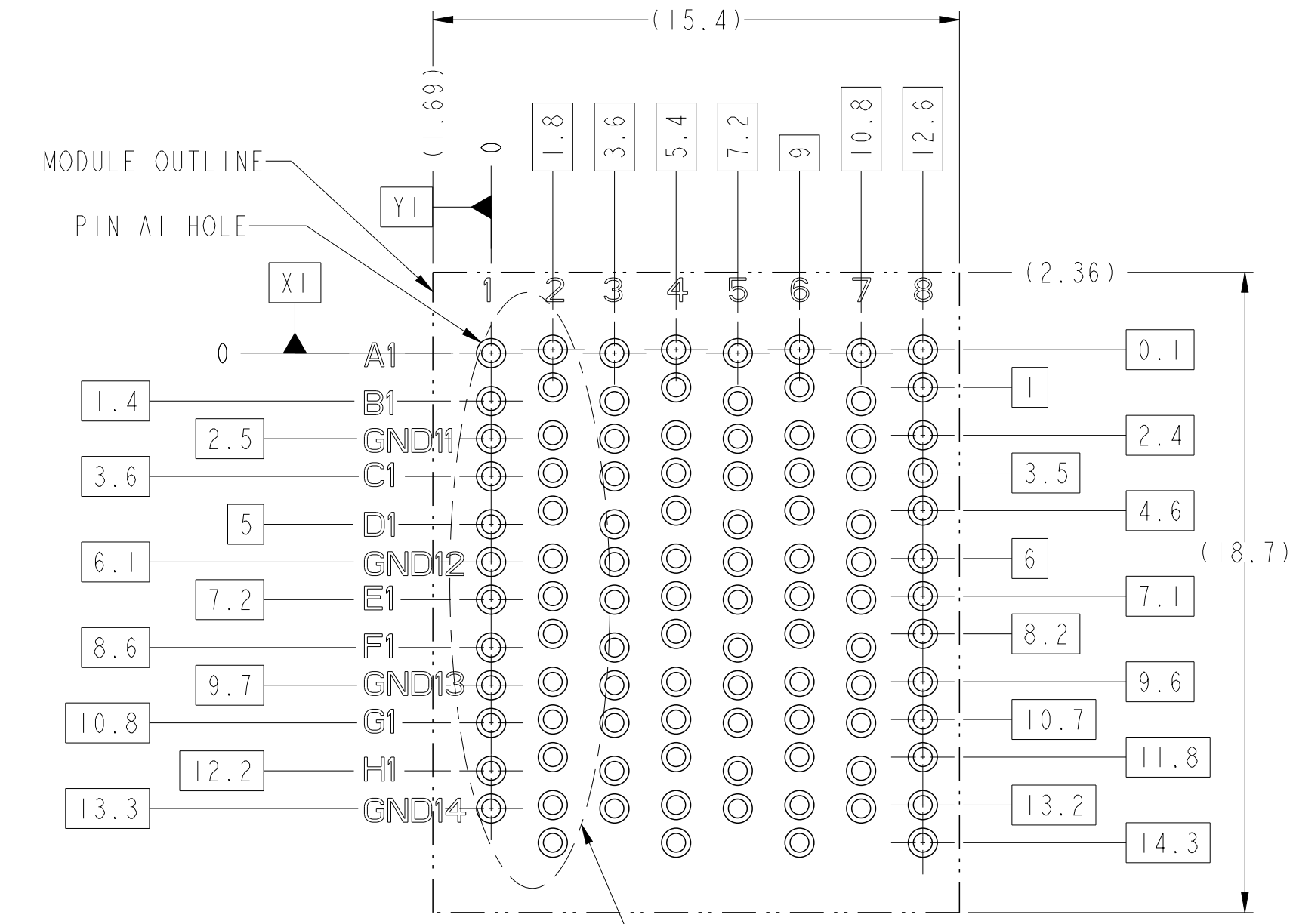
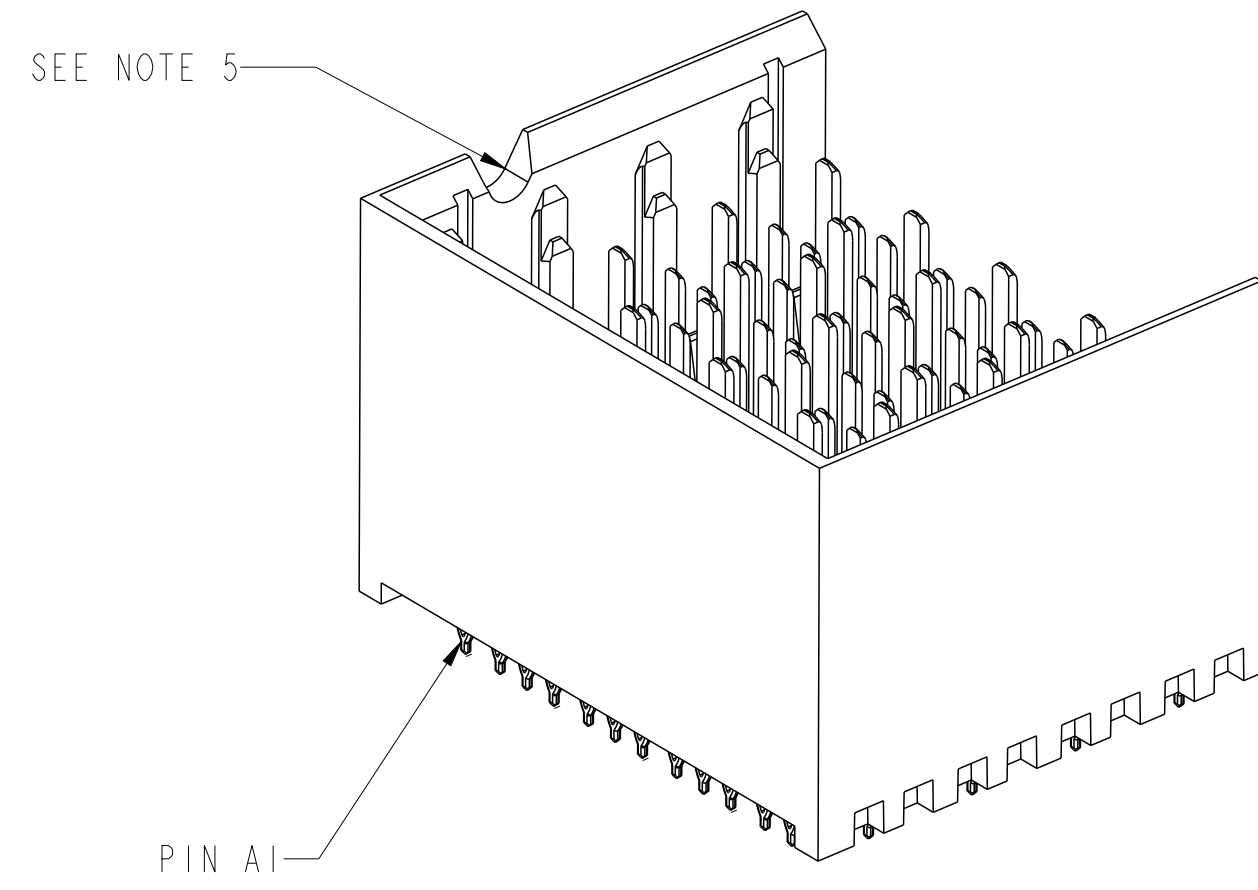

SEE DETAIL A
On Sheet 8 For Details

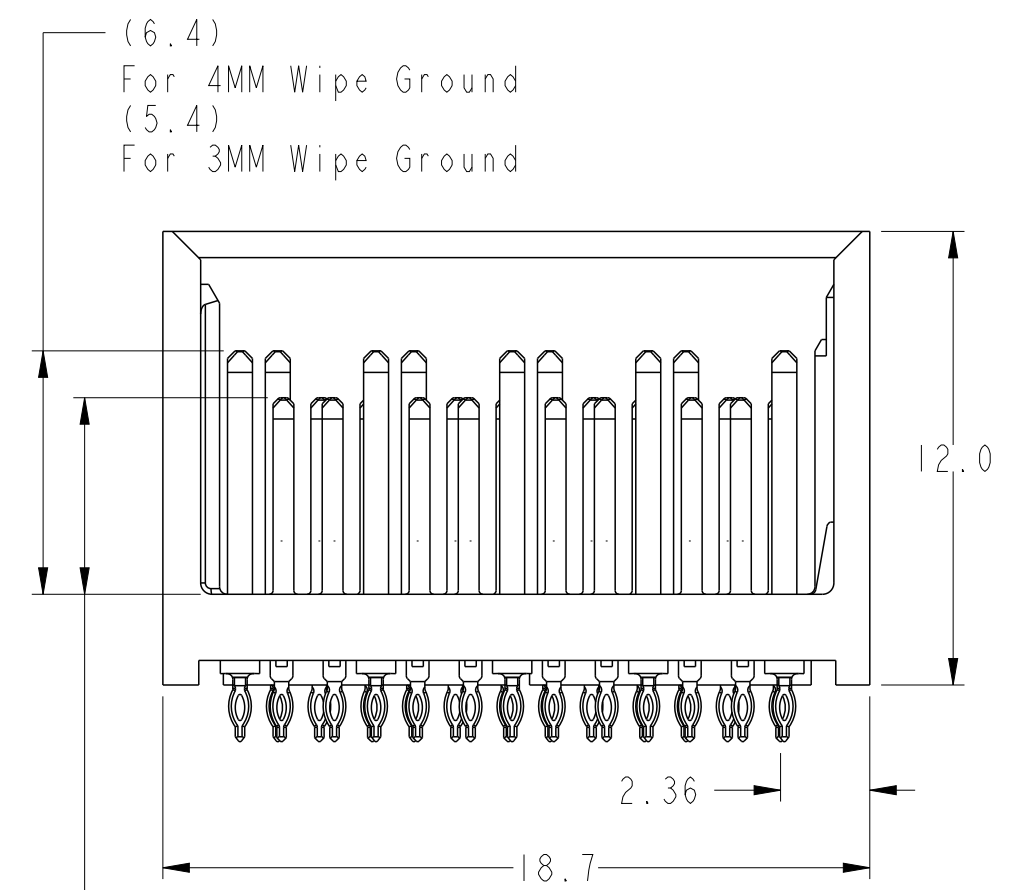
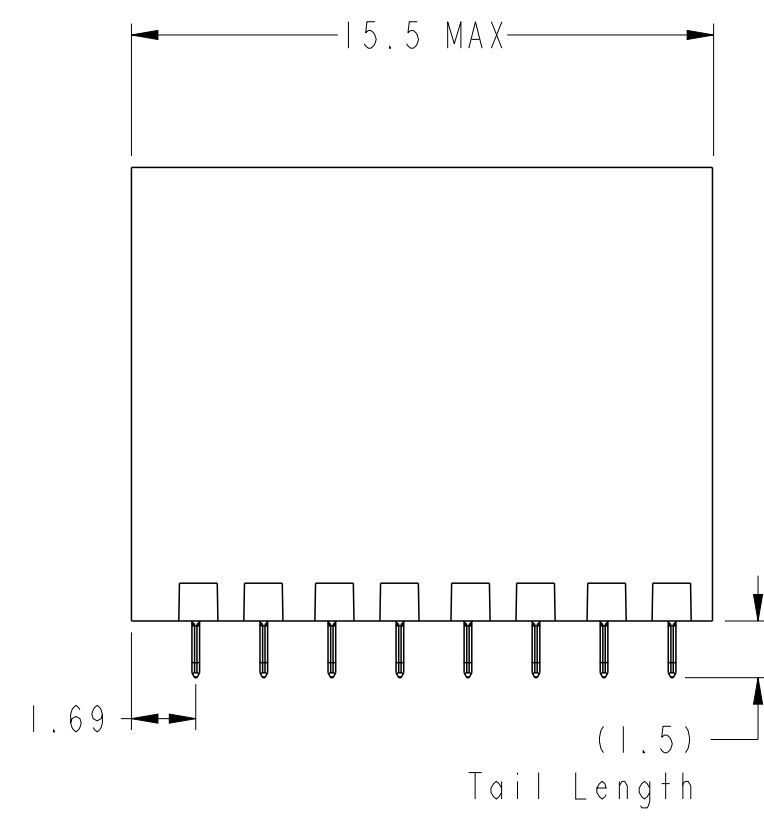

BP HOLE PATTERN COMPONENT SIDE
LEFT WALL MODULE BACKPLANE FOOTPRINT

Amphenol
FCi

© 2016 AFCI

spec ref	-	dr	Collins Lu	2011/07/27	projection	mm	size	A2	scale	1:1
tolerance std	ISO 406 ISO 1101	eng	Sandar Soe	2016/03/07		mm	ecn no	ELX-S-17624-1	rel level	Released
TOLERANCES UNLESS OTHERWISE SPECIFIED		chr	-	appr						
surface	ISO 1302	linear	0.X	±0.3			MODULE ASSEMBLY, XCEDE HD Vertical Header, 4 Pair 8 Column		dwg no 10115091	rev E
		angular	0°	±2°	www.fci.com	cat. no.	-	Product - Customer Drw	sheet 3 of 8	

PDS: Rev :E

STATUS:Released

Printed: Mar 17, 2016

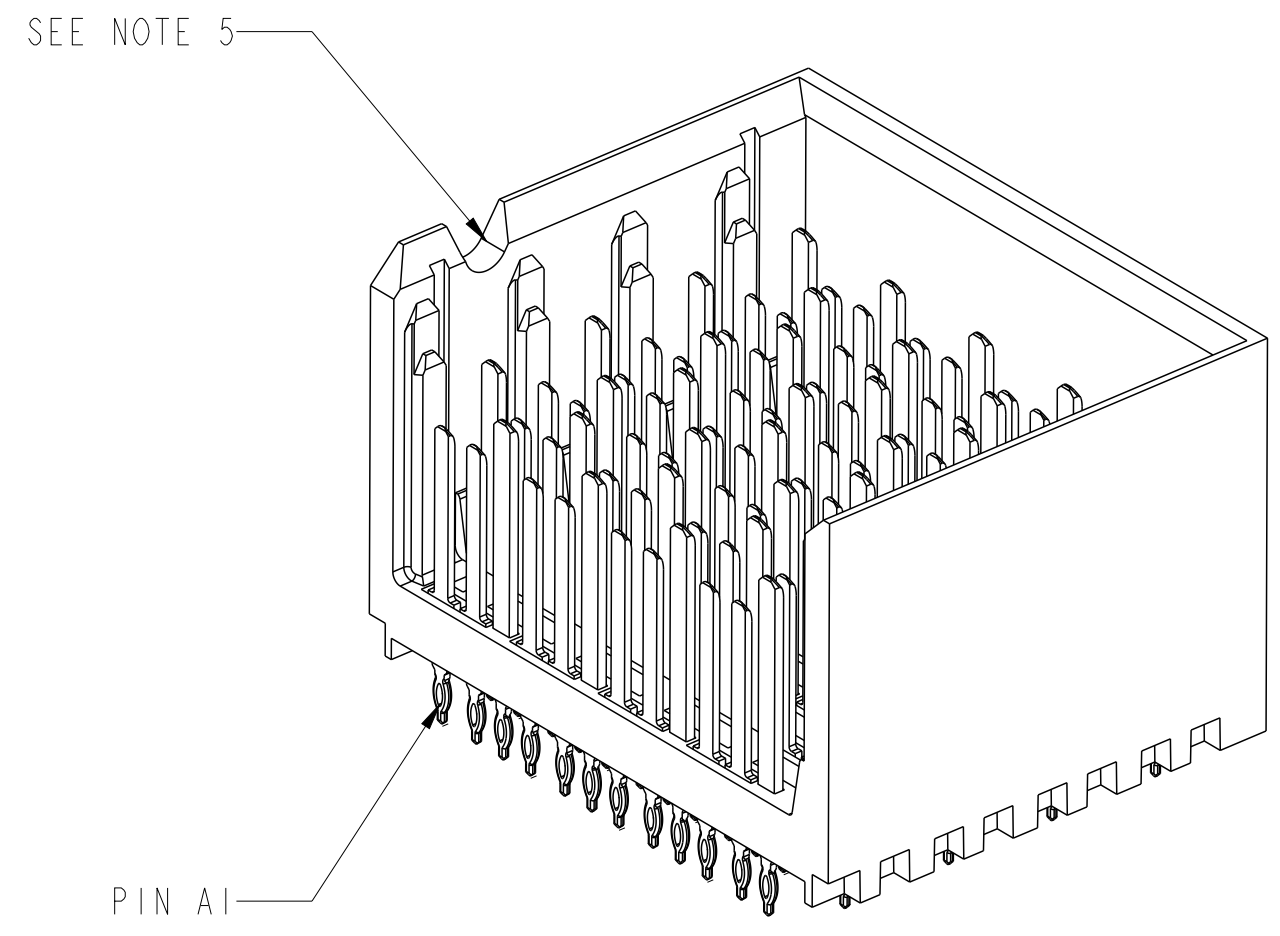
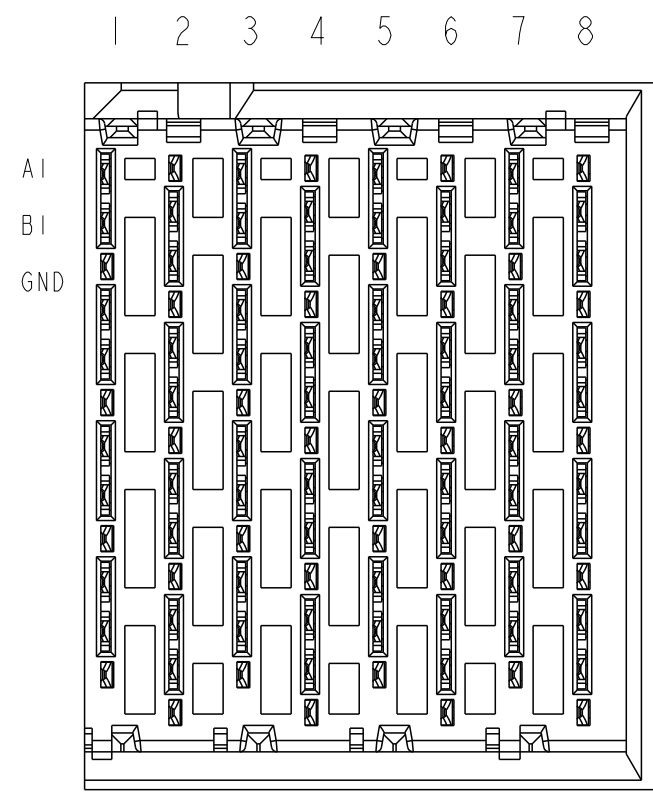

RIGHT WALL MODULE

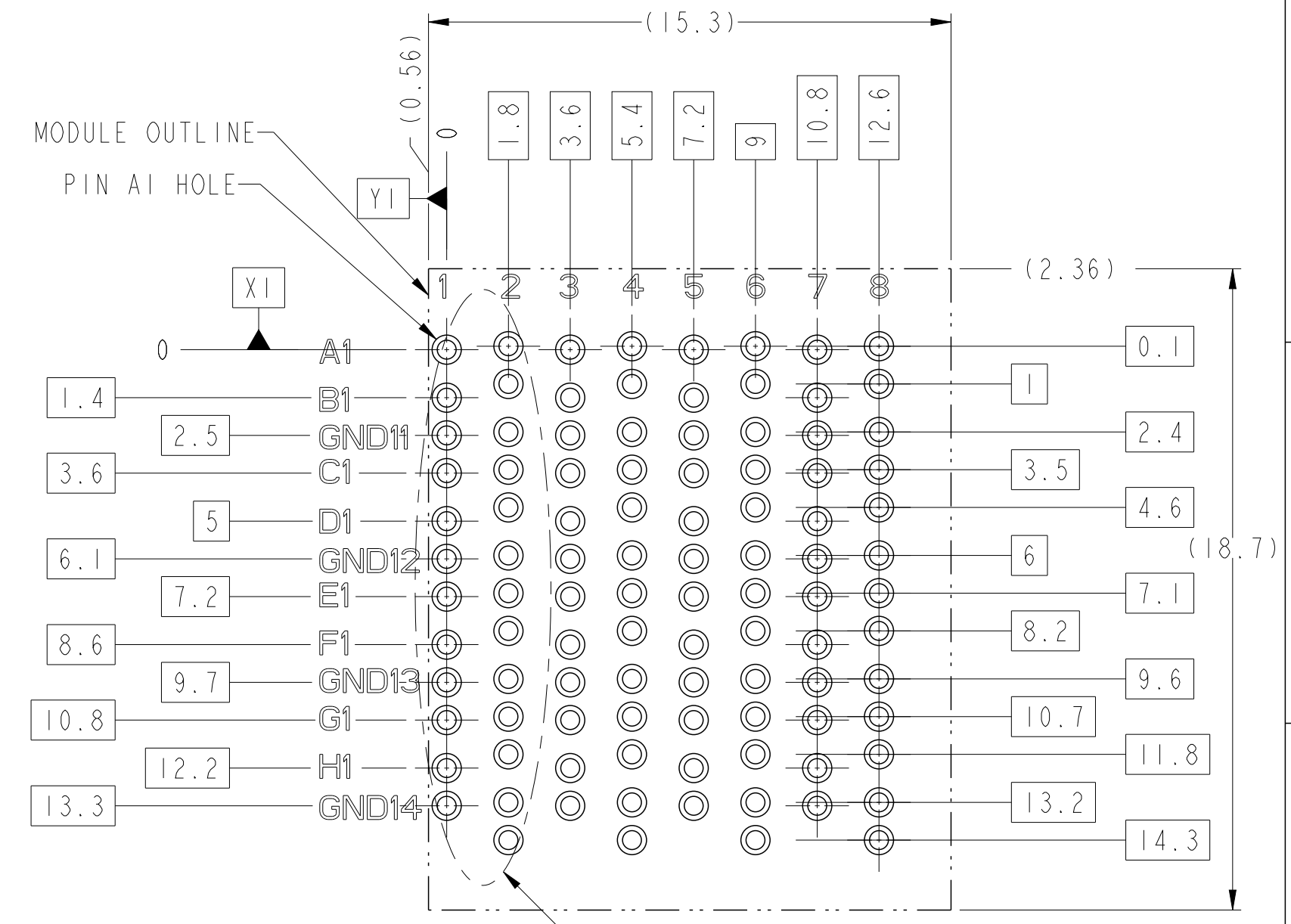

SEE DETAIL A
On Sheet 8 For Details

BP HOLE PATTERN COMPONENT SIDE

RIGHT WALL MODULE BACKPLANE FOOTPRINT

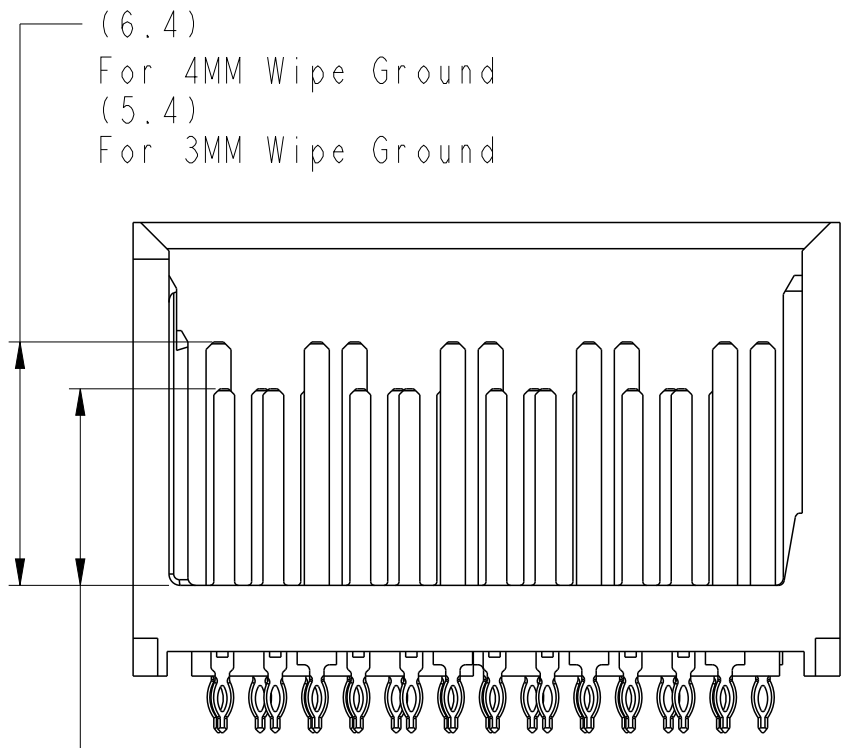

(6.4)
For 4MM Wipe Ground
(5.4)
For 3MM Wipe Ground

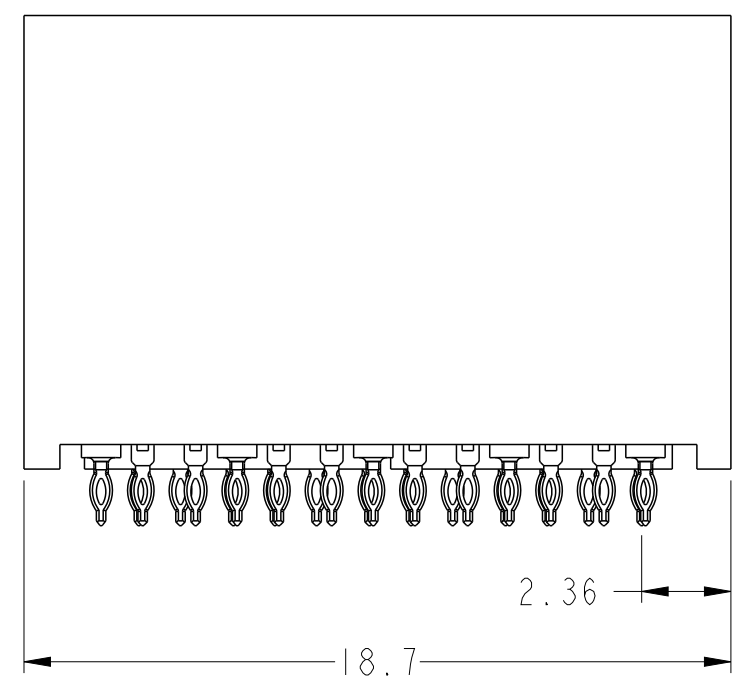
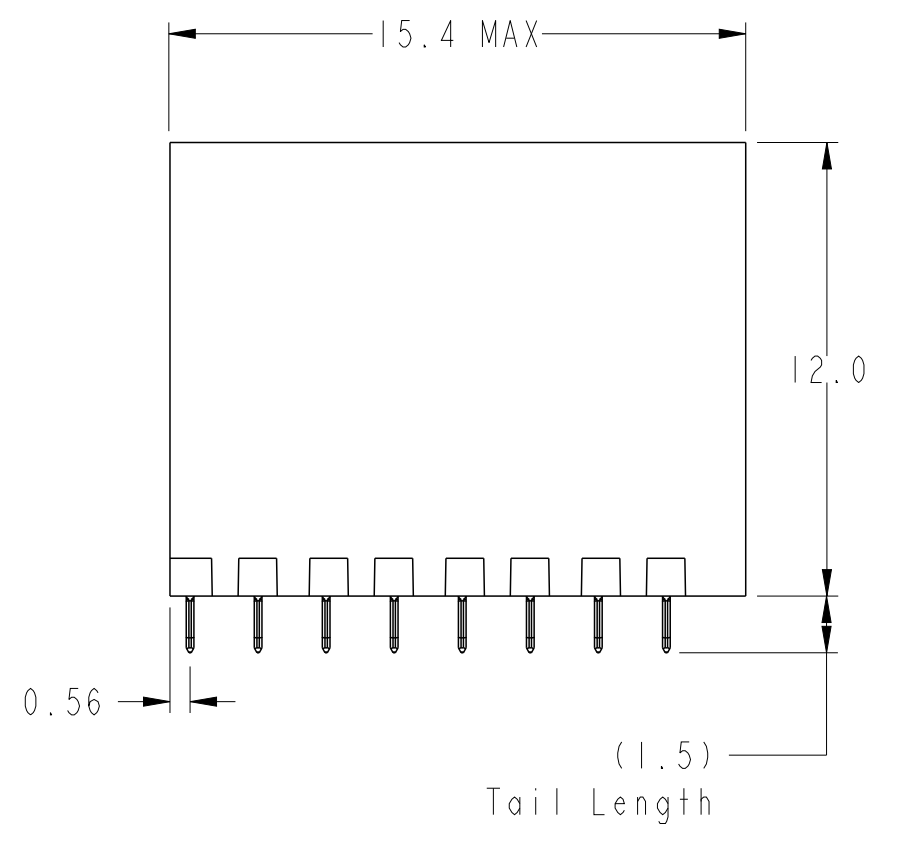

(5.2)
For 3MM Wipe Signal
(4.2)
For 2MM Wipe Signal

Amphenol
FCi

© 2016 AFci

spec ref	-	dr	Collins Lu	2011/07/27	projection	mm	size	A2	scale	1:1			
tolerance std	ISO 406 ISO 1101	eng	Sandar Soe	2016/03/07		mm	ecn no	ELX-S-17624-1	rel level	Released			
TOLERANCES UNLESS OTHERWISE SPECIFIED		chr	-	appr							Chen-Hong Tan	2016/03/17	product family
surface	ISO 1302	linear	0.X	±0.3			title	MODULE ASSEMBLY, XCEDE HD		dwg no	10115091	rev	E
		angular	0°	±2°	www.fci.com	cat. no.	-	Product - Customer Drw	sheet 4 of 8				

PDS: Rev :E

STATUS:Released

Printed: Mar 17, 2016

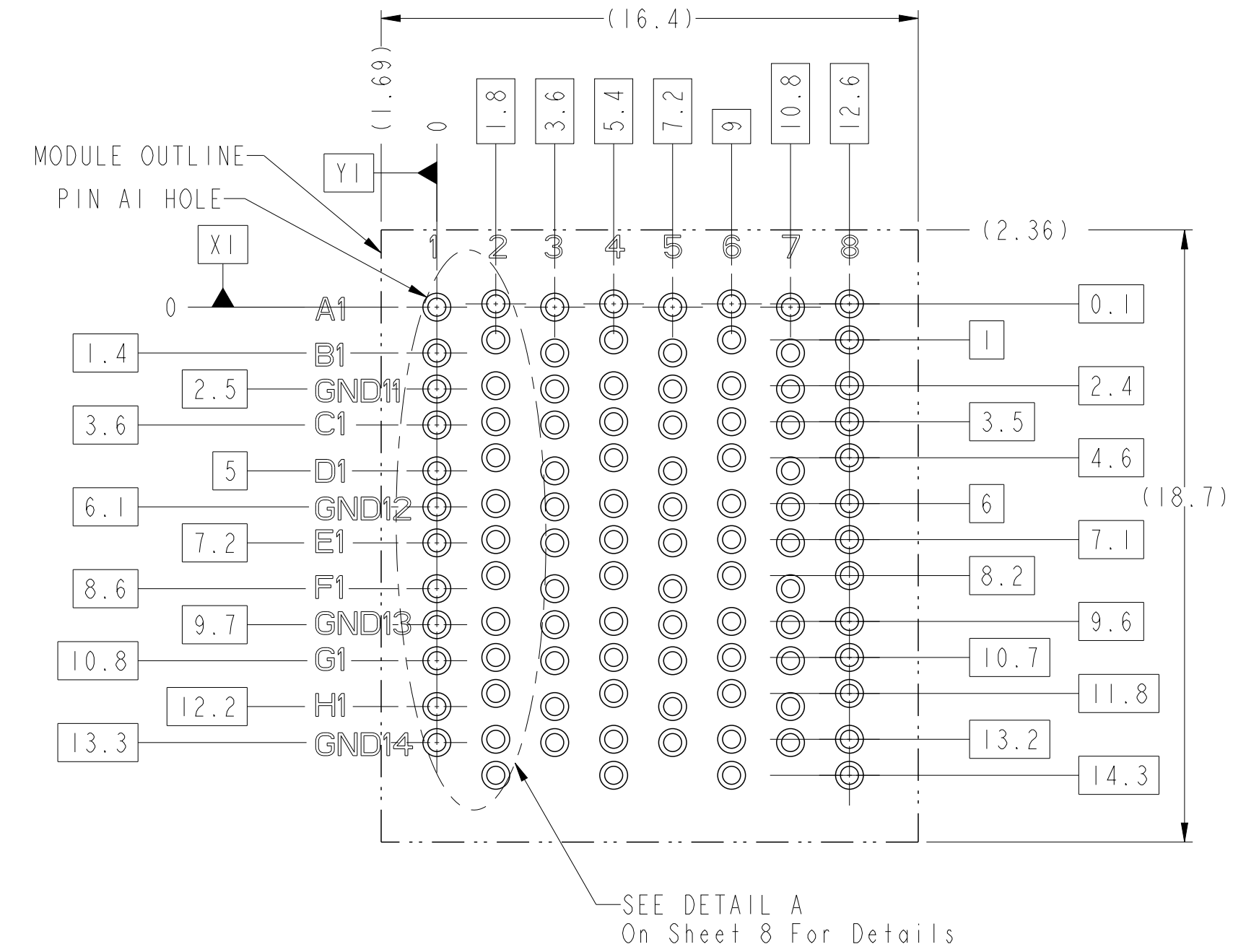
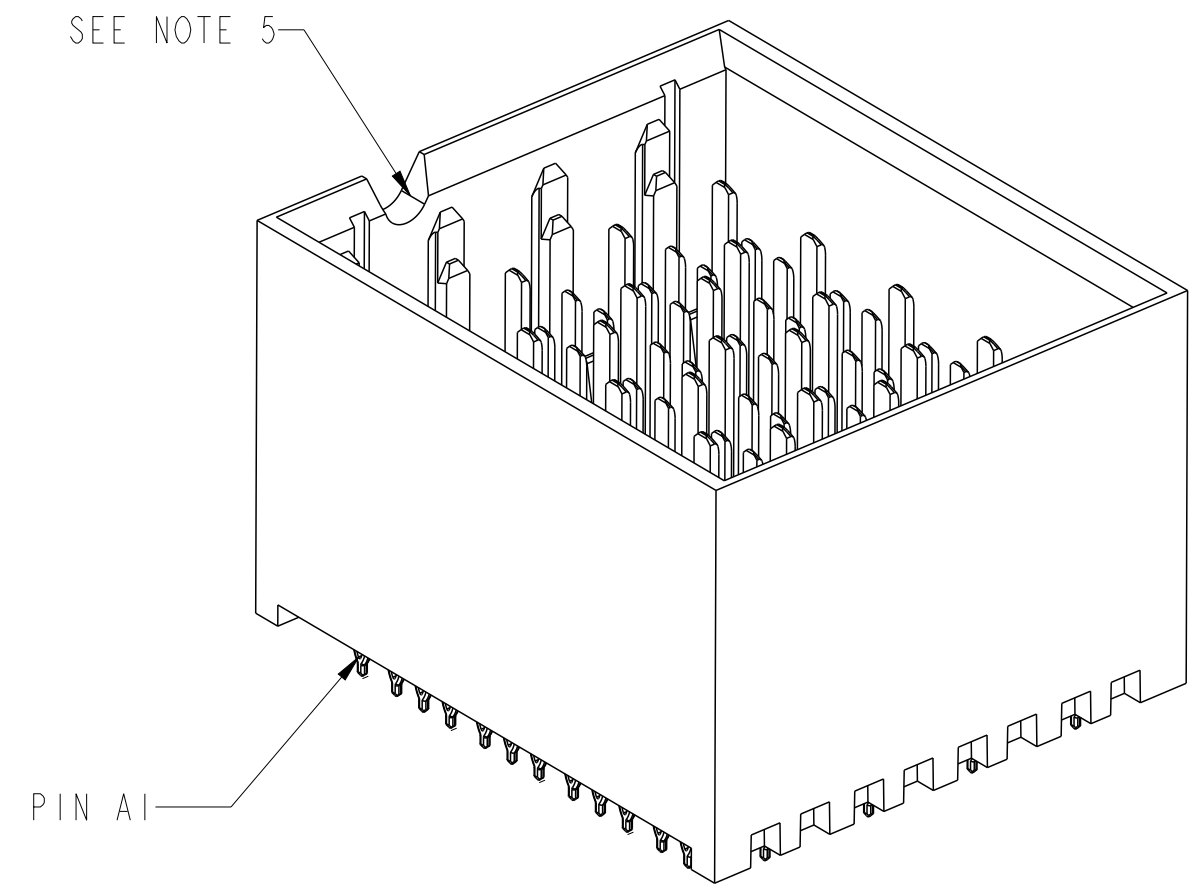
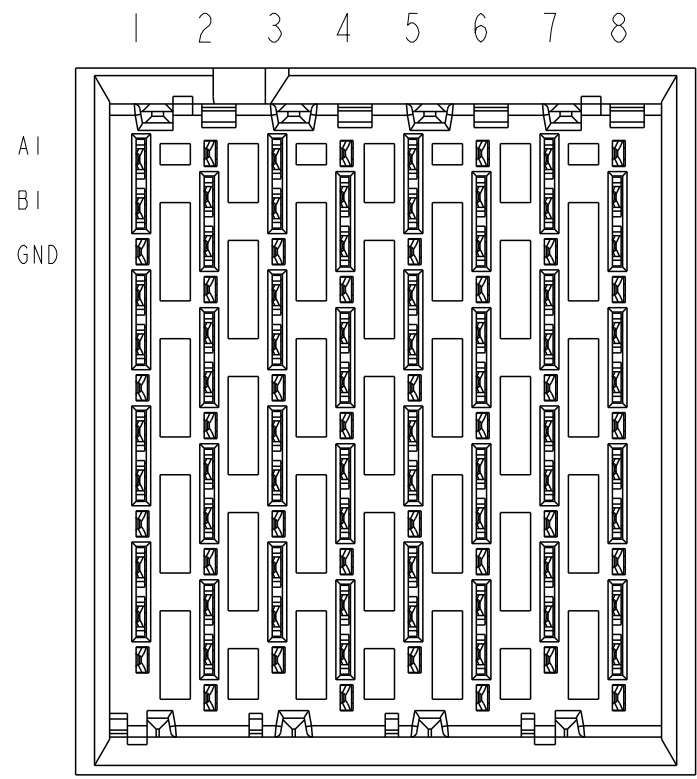

△ FOUR WALL MODULE

BP HOLE PATTERN COMPONENT SIDE

△ FOUR WALL MODULE BACKPLANE FOOTPRINT

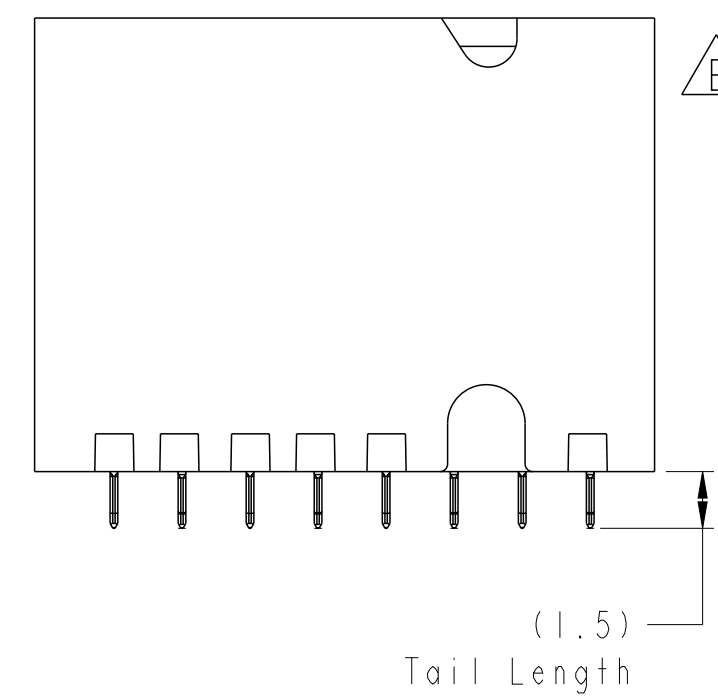
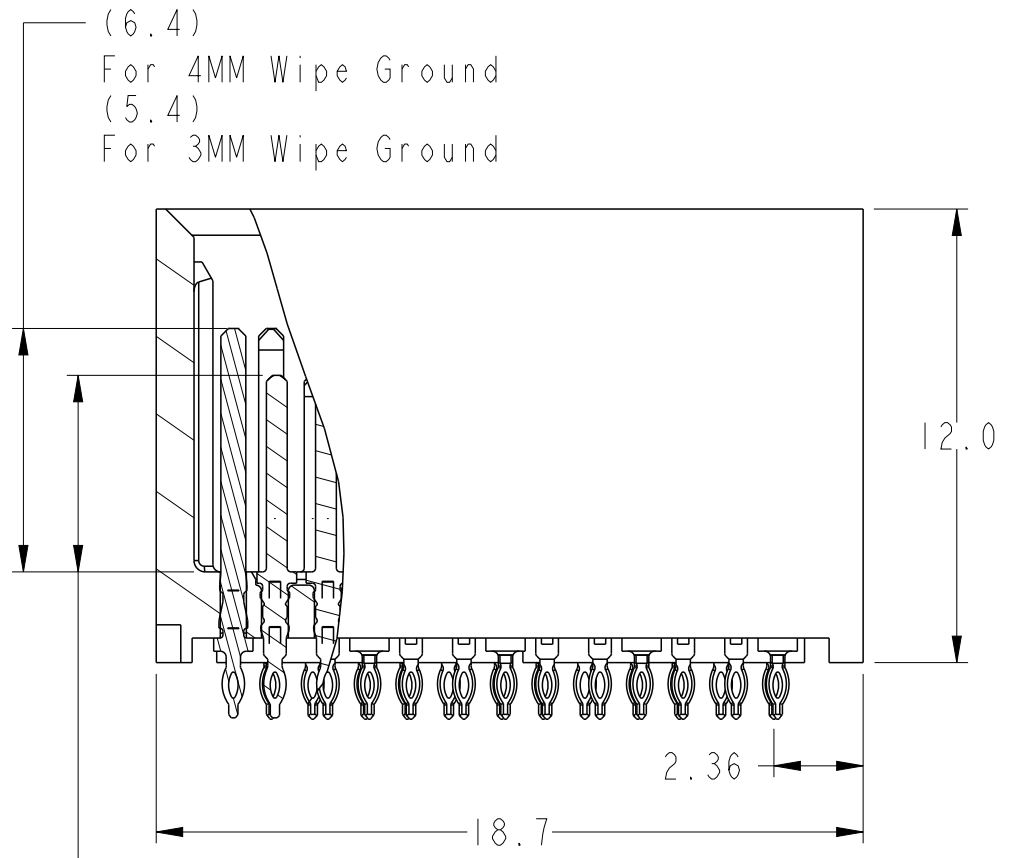
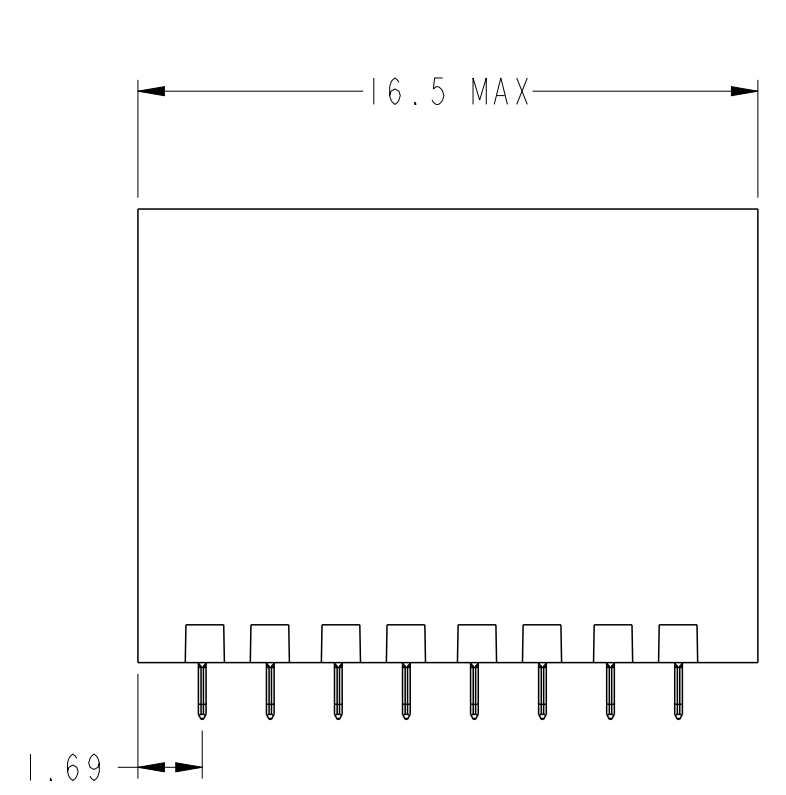

Amphenol
FCi

© 2016 AFci

spec ref	-	dr	Collins Lu	2011/07/27	projection	mm	size	A2	scale	1:1
tolerance std	ISO 406 ISO 1101	eng	Sandar Soe	2016/03/07		mm	ecn no	ELX-S-17624-1	rel level	Released
TOLERANCES UNLESS OTHERWISE SPECIFIED		chr	-	appr						
surface	linear	0.X	±0.3	Amphenol FCi www.fci.com	MODULE ASSEMBLY, XCEDE HD Vertical Header, 4 Pair 8 Column		dwg no 10115091	rev E	Product - Customer Drw	
		0.XX	±0.10		cat. no.	-			sheet 5 of 8	
	angular	0°	±2°							

PDS: Rev :E

STATUS:Released

Printed: Mar 17, 2016

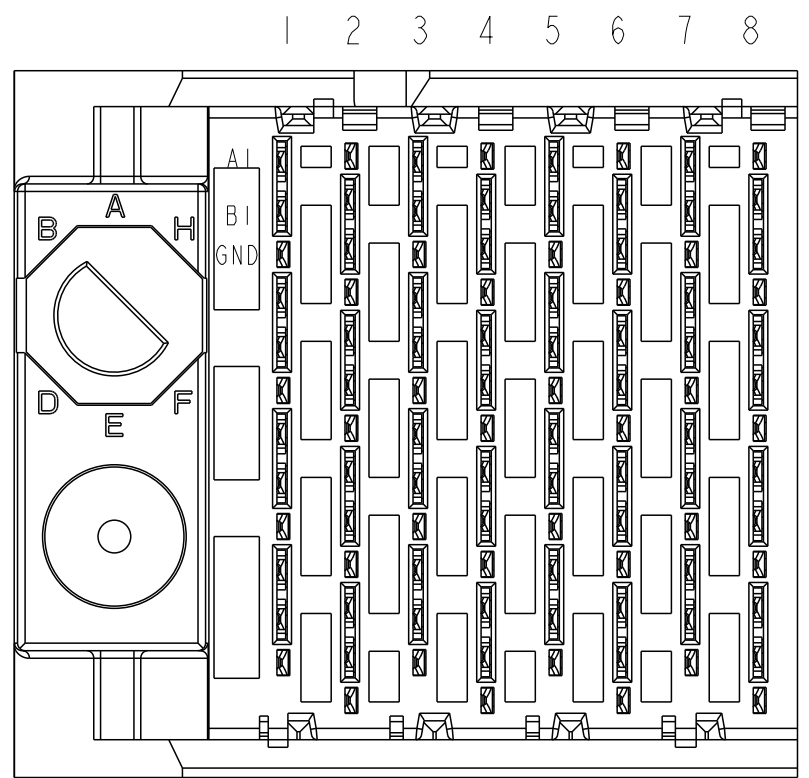

LEFT POLARIZING/GUIDE MODULE

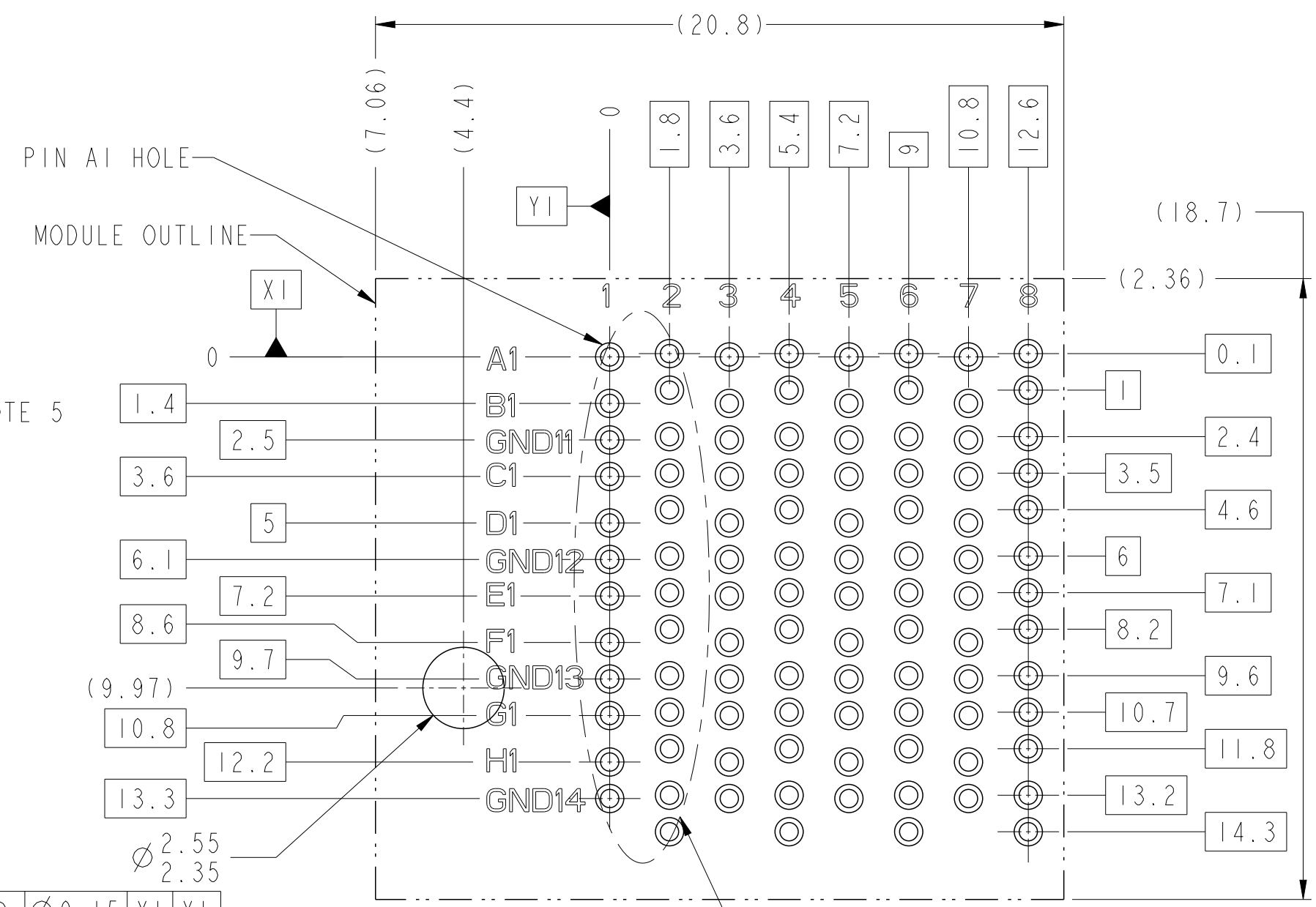
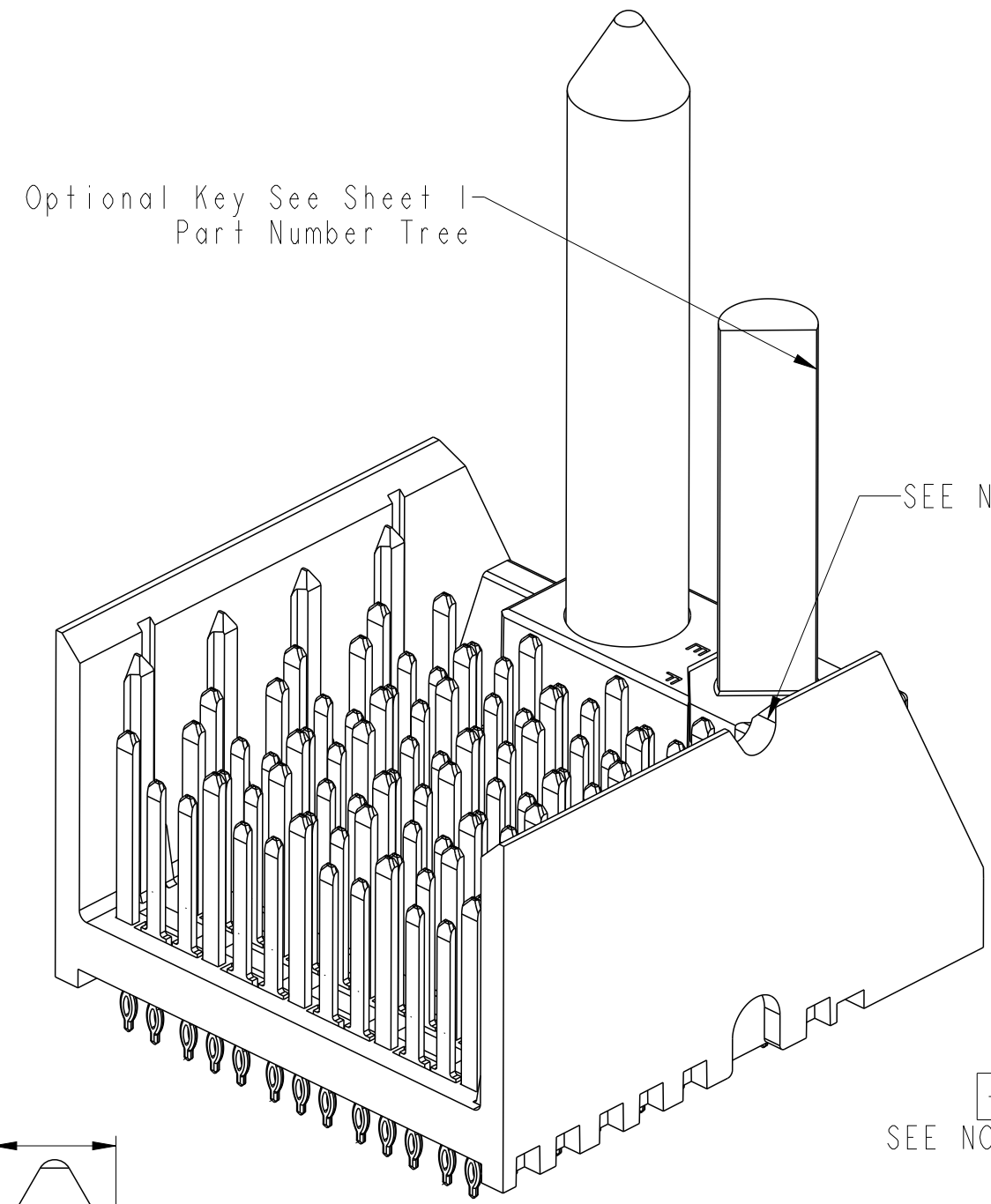

SEE NOTE 11 & TABLE 1

SEE DETAIL A OnSheet 8 For Details

BP HOLE PATTERN COMPONENT SIDE
LEFT POLARIZING GUIDE MODULE
BACKPLANE FOOTPRINT

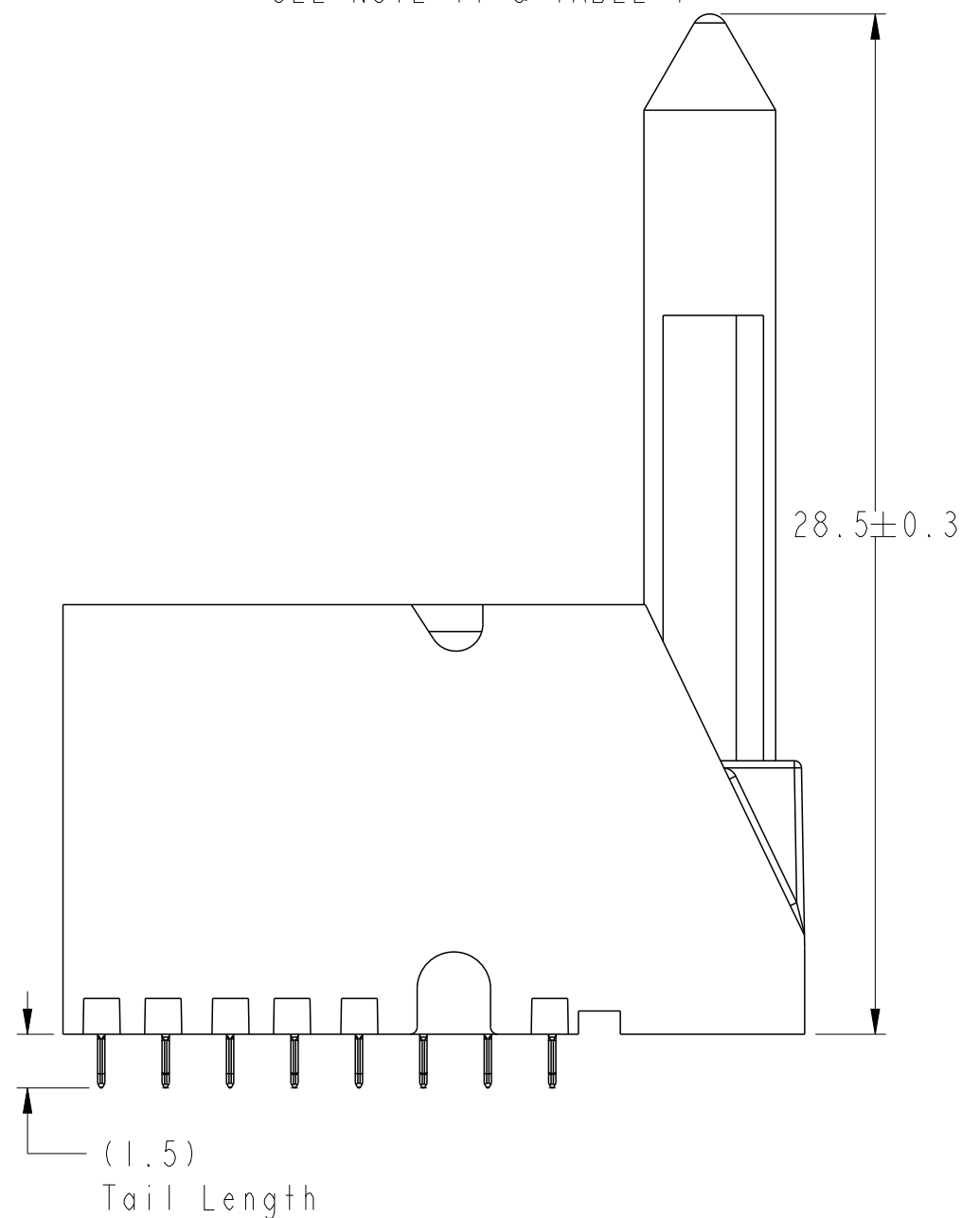
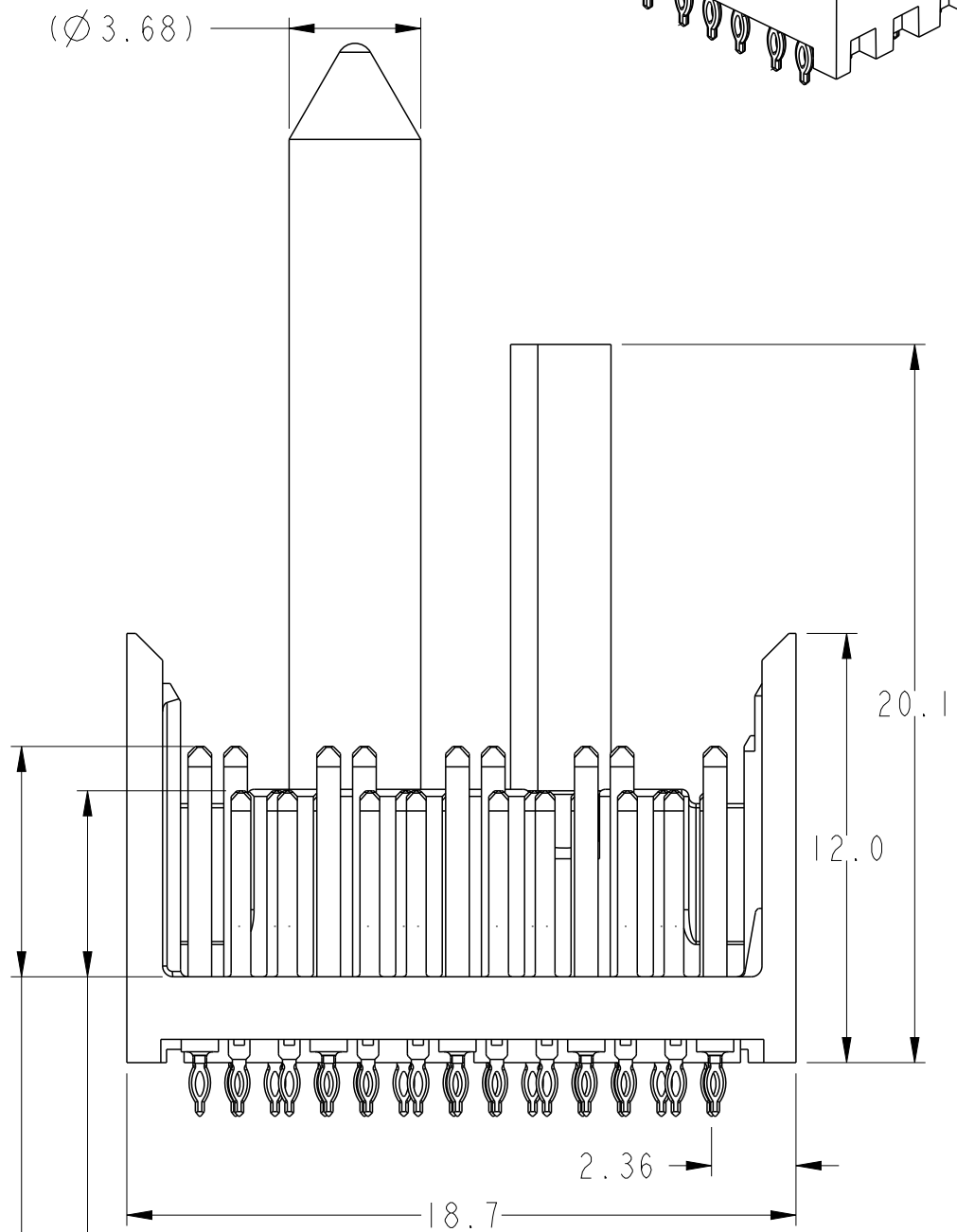
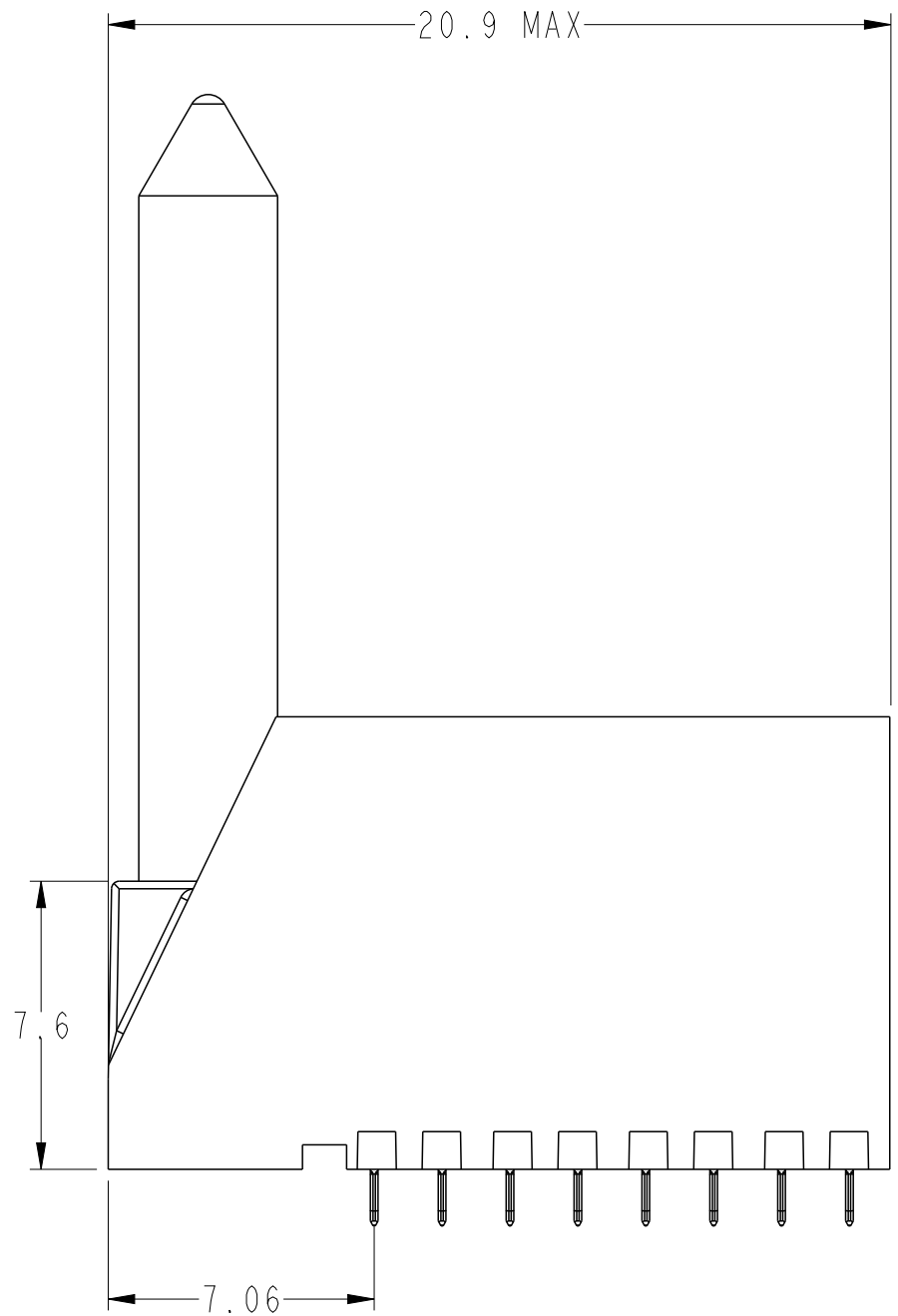

(5.2)
For 3MM Wipe Signal
(4.2)
For 2MM Wipe Signal
(6.4)
For 4MM Wipe Ground
(5.4)
For 3MM Wipe Ground

spec ref	-	dr	Collins Lu	2011/07/27	projection	mm	size	A2	scale	1:1		
tolerance std	ISO 406 ISO 1101	eng	Sandar Soe	2016/03/07		mm	ecn no	ELX-S-17624-1	rel level	Released		
TOLERANCES UNLESS OTHERWISE SPECIFIED		chr	-	appr							Chen-Hong Tan	2016/03/17
surface	ISO 1302	linear	0.X	± 0.3			MODULE ASSEMBLY, XCEDE HD Vertical Header, 4 Pair 8 Column	dwg no 10115091	rev E	cat. no. -	Product - Customer Drw	sheet 6 of 8

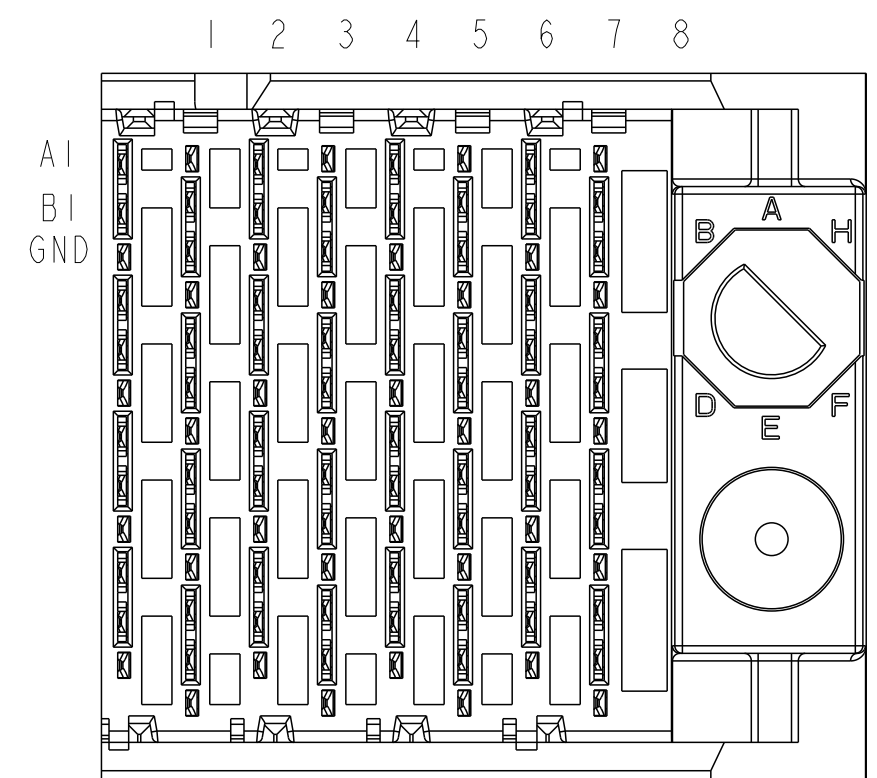

Optional Key See Sheet 1
Part Number Tree

SEE NOTE 5

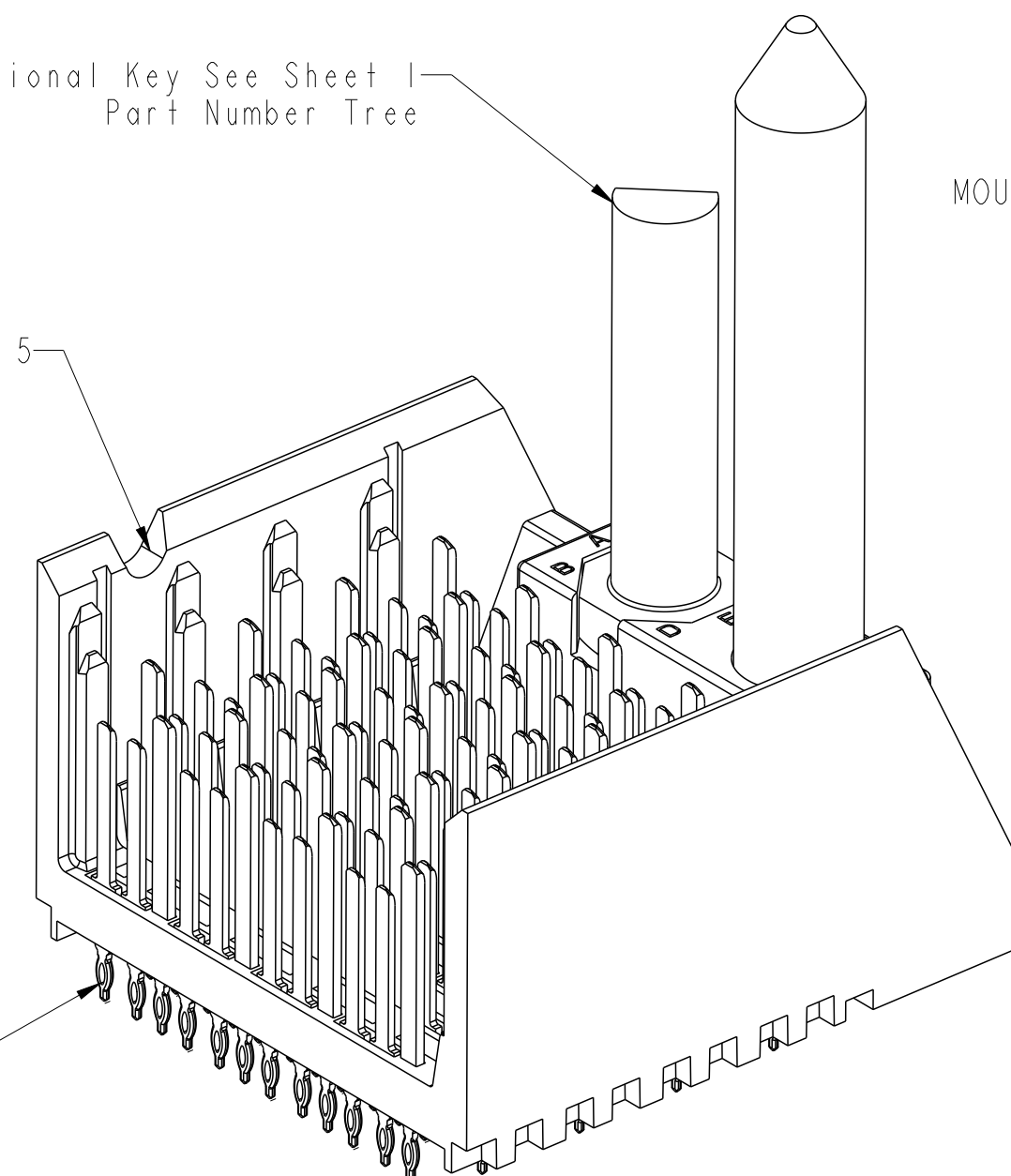

PIN A1

MODULE OUTLINE
PIN A1 HOLE

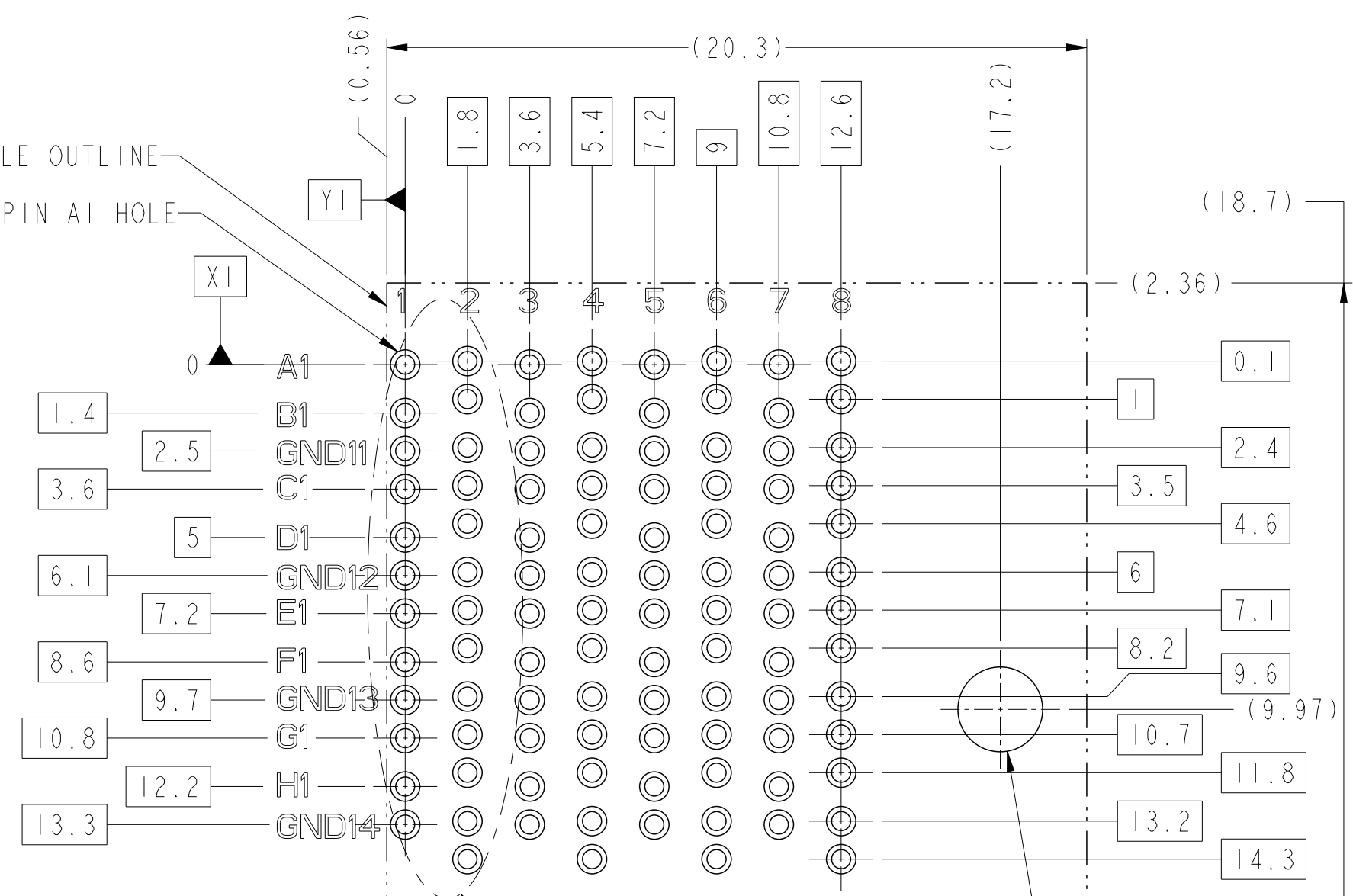

SEE DETAIL A
On Sheet 8 For Details

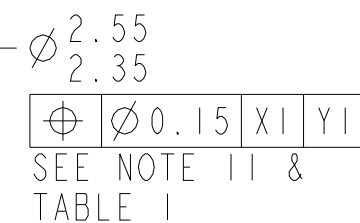

BP HOLE PATTERN COMPONENT SIDE
RIGHT POLAIZING/GUIDE MODULE
BACKPLANE FOOTPRINT

RIGHT POLARIZING/GUIDE MOUDLE

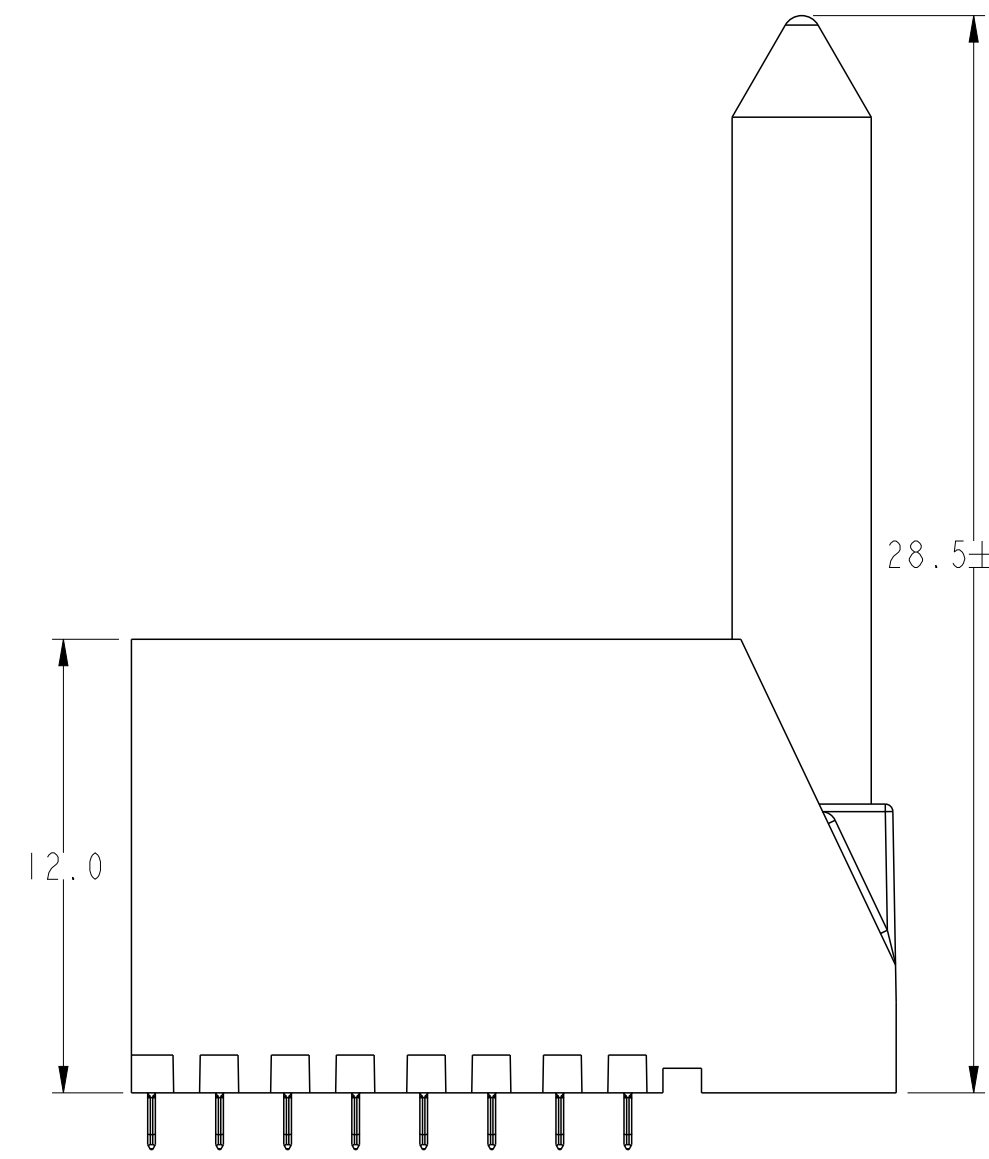
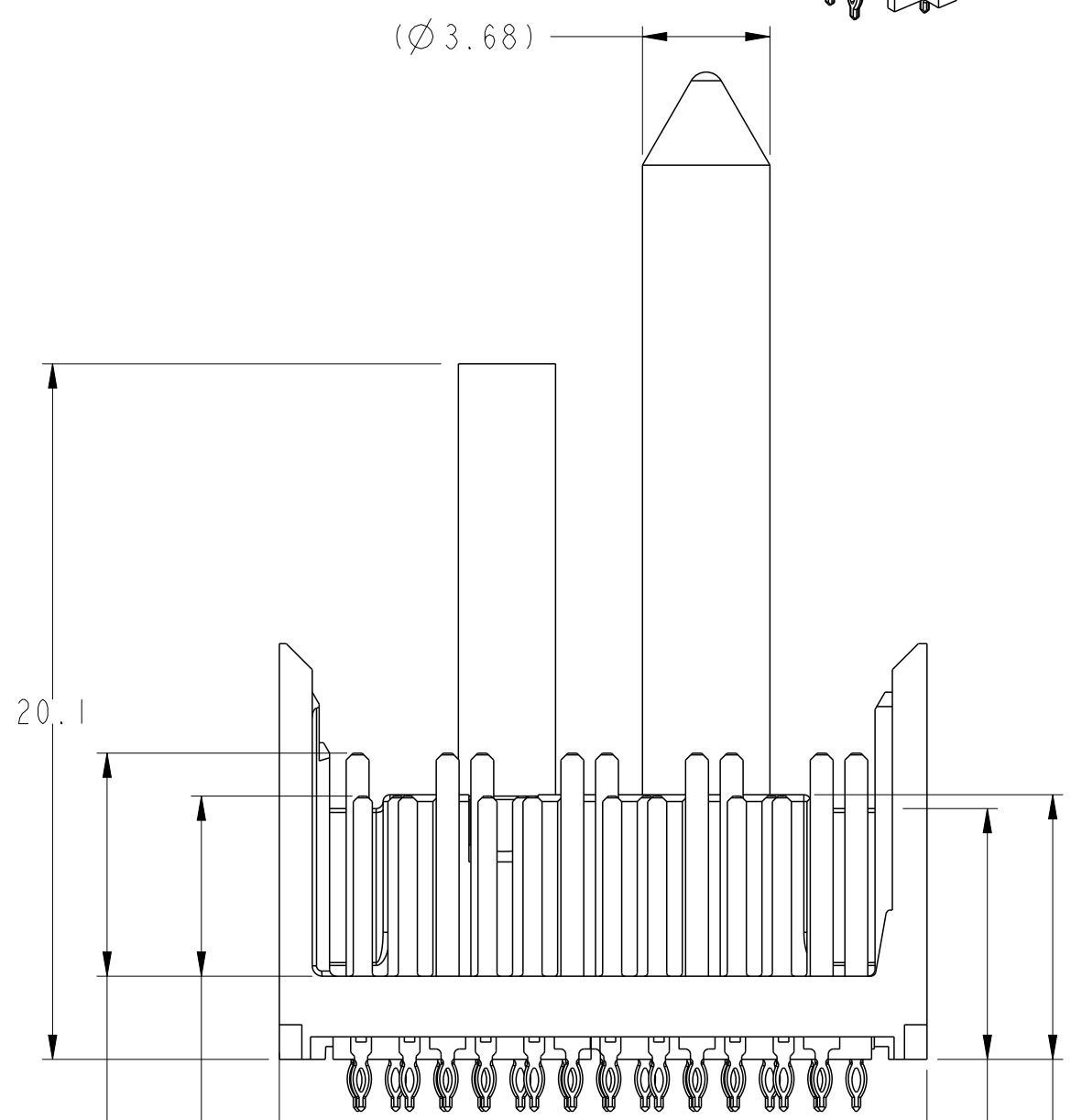
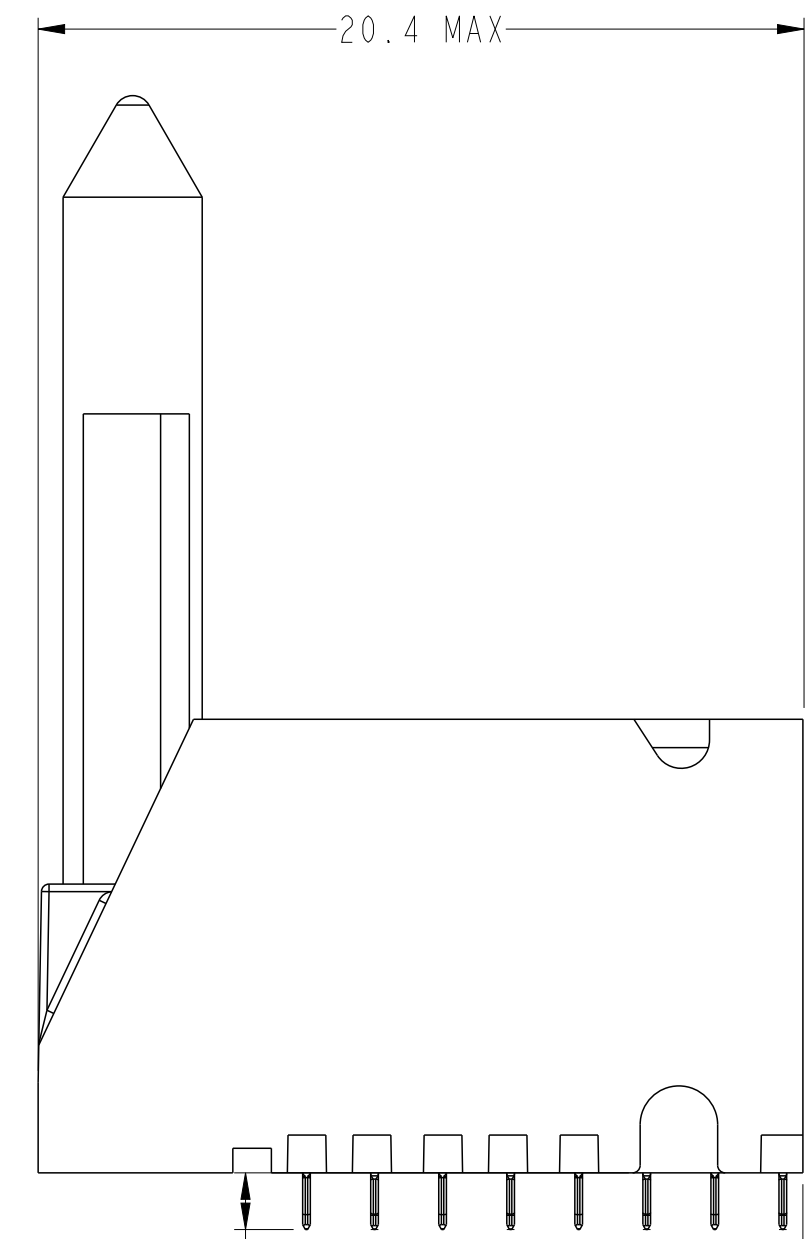

(1.5)
Tail Length

- (5.2) For 3MM Wipe Signal
- (4.2) For 2MM Wipe Signal
- (6.4) For 4MM Wipe Ground
- (5.4) For 3MM Wipe Ground

spec ref	-	dr	Collins Lu	2011/07/27	projection	mm	size	A2	scale	1:1
tolerance std	ISO 406 ISO 1101	eng	Sandar Soe	2016/03/07	chr	-	ecn no	ELX-S-17624-1	rel level	Released
surface	ISO 1302	appr	Chen-Hong Tan	2016/03/17	product family	-	cat. no.	Product - Customer Drw	sheet 7 of 8	
linear	0.X ±0.3 0.XX ±0.10 0.XXX ±0.05	angular	0° ±2°	Amphenol FCI MODULE ASSEMBLY, XCEDE HD Vertical Header, 4 Pair 8 Column		dwg no 10115091	rev E			

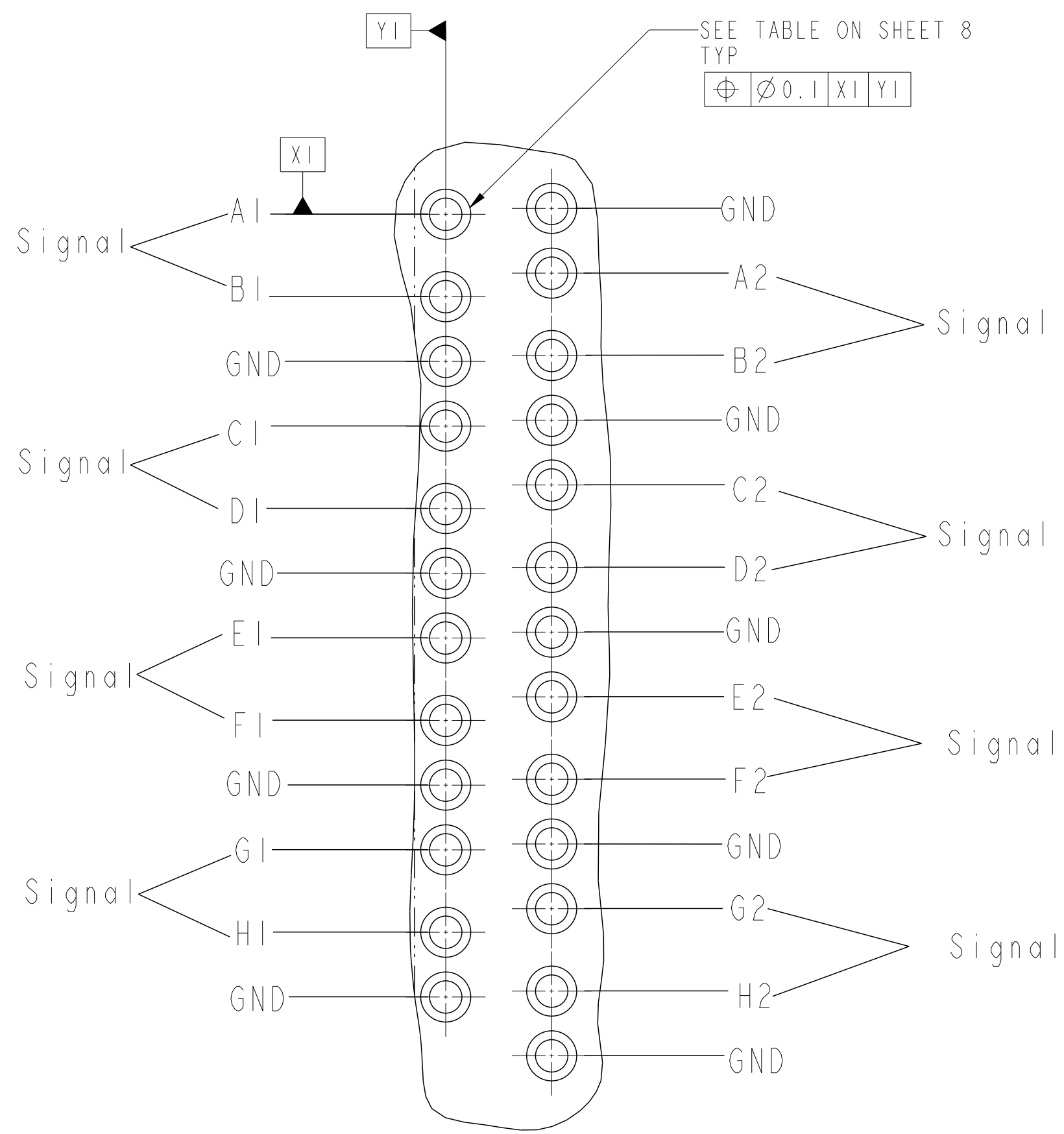

DETAIL A
SCALE 12:1

TABLE 3		
	COMPLIANT PIN DRILL $\varnothing 0.55 [0.0217"]$	COMPLIANT PIN DRILL $\varnothing 0.45 [0.0177"]$
PTH	$\varnothing 0.45 \pm 0.05$	$\varnothing 0.36 \pm 0.05$
DRILL	$\varnothing 0.55 [0.0217"]$	$\varnothing 0.45 [0.0177"]$
PAD	$\varnothing 0.85$	$\varnothing 0.75$

NOTES:

1. CONNECTOR MATERIALS
SHROUD : HIGH-TEMP POLYMER, COLOR : BLACK, UL94V-0
CONTACTS : HIGH PERFORMANCE COPPER ALLOY
2. PRODUCT SPECIFICATION : GS-12-0936
3. APPLICATION SPECIFICATION : GS-20-0348
4. PRODUCT MARKING :
PART NUMBER (10115091-XOE-XXXLF)
"FCI" AND DATE CODE (FCI P#####)
5. NOTCH DESIGNATES "ROW A" SIDE OF CONNECTOR. NOTCH FEATURE ON OPPOSITE FOR PRODUCT MARKING.
6. PLATING THICKNESS OF SIGNAL & GROUND CONTACT ARE DETERMINED BY PLATING CODE, REFER TO P/N TREE ON SHEET 1.
7. PACKAGING MEETS GS-14-920 LEAD-FREE LABELING SPECIFICATION.
8. GUIDE-PIN STYLE DESIGNATION ONLY APPLIES TO MODULE VERSIONS THAT REQUIRE GUIDE-PIN HARDWARE. FOR ALL NON-GUIDE-PIN VERSIONS, THE DEFAULT DASH-NUMBER DIGIT IN THAT LOCATION IS STILL "0".
9. SEE APPLICATION SPECIFICATION FOR ROUTING GUIDELINES, ADDITIONAL PTH GUIDELINES, MATED DIMENSIONS, GUIDE PIN SELECTION, ETC.
10. A $\triangle E$ SYMBOL WILL BE NEXT TO ANY DIMENSION, VIEW OR NOTE THAT HAS BEEN MODIFIED WITH THE CURRENT DRAWING REVISION.
11. OPTIONAL HOLE LOCATION FOR GROUNDED PIN OR ADDITIONAL GUIDE-PIN SUPPORT. SEE TABLE 1 SHEET 1 FOR ADDITIONAL DETAILS.
12. SCREW IS OPTIONAL AND ENGAGES WITH BOTTOM OF GUIDE PIN FROM BENEATH THE PCB FOR ADDITIONAL GUIDE-PIN SUPPORT.

Amphenol
FCi

© 2016 AFci

spec ref	-	dr	Collins Lu	2011/07/27	projection	mm	size	A2	scale	1:1		
tolerance std	ISO 406 ISO 1101	eng	Sandar Soe	2016/03/07			ecn no	ELX-S-17624-1	rel level	Released		
TOLERANCES UNLESS OTHERWISE SPECIFIED		chr	-	apppr			Chen-Hong Tan	2016/03/17		product family	Module Assembly, XCEDE HD Vertical Header, 4 Pair 8 Column	part no
surface	ISO 1302	linear	0.X	± 0.3			rev	E	cat. no.	-	Product - Customer Drw	sheet 8 of 8
		angular	0°	$\pm 2^\circ$	www.fci.com							

PDS: Rev :E

STATUS:Released

Printed: Mar 17, 2016