

Revision level		Revision Record	Changed	Date	Approved	Date
part	drawing					
-	02	See ECN 010754	A.A.C.	05/11/07	K.A.C.	05/14/07

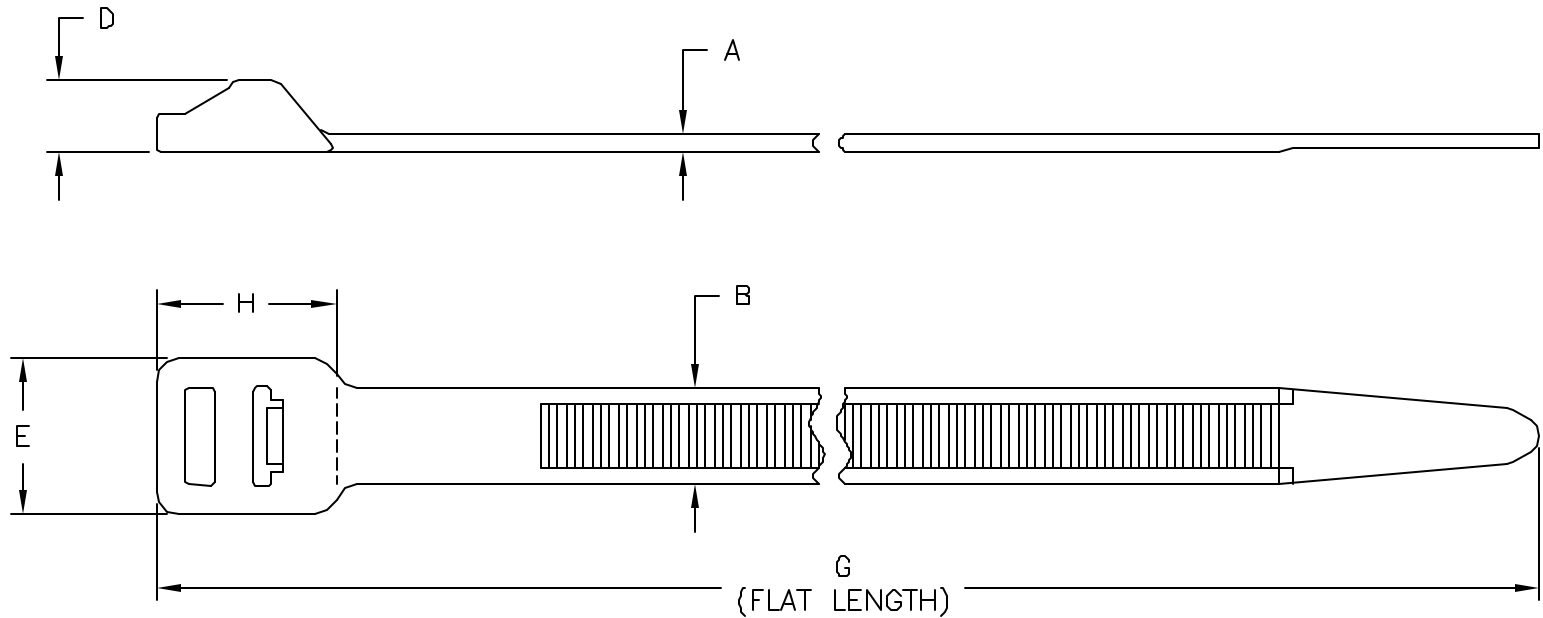

PRODUCT CODE DESCRIPTION

T250L_HSUUV

COLOR
(CONSULT FACTORY FOR AVAILABLE COLORS)

Group Number (UNS)	Aerospace Spec Tie SAE AS33671	Product Code	Cable Range (mm)	Material	A	B	D	E	G	H	Min Loop Tensile Strength (newtons)
-	no	T250L_	12 to 254	PA66	2.2 ±0.2	12.5±0.2	9.5 ±0.5	20.0 ±0.5	880.0 ±5.0	22.4 ±1.0	1115
-		T250L_VO		PA66VO							
-		T250L_HSUUV		PA66HSUUV							

SEE CHART



Material

Dimension tolerances unless otherwise specified
 .XXXX =
 .XXX =
 .XX =
 .X = ± NOTED
 < =

Dimension Units mm

PERFORMANCE SPECIFICATION

ACAD MECH
2007

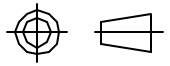

Drawn A.A.C. 01/18/02
 Approved K.A.C. 05/14/07

Scale 1:1
 Computer File Number CT\CST\2250009_02
 Title

ALL PROPRIETARY RIGHTS IN THE SUBJECT MATTER SHOWN ON THIS DRAWING ARE EXCLUSIVE PROPERTY OF HELLERMANN TYTON

HellermannTyton

7930 N. Faulkner Rd.
 Milwaukee, WI 53224
 Ph: (414) 355-1130
 Fx: (414) 362-8338

**T250L
 HEAVY DUTY
 LASHING CABLE TIE**

Drawing-No **CT2250009CST**
 Format AH
 Sheet 1 of 1