



# **MPU-9150 9-Axis Evaluation Board User Guide**



## Table of Contents

<b>1. REVISION HISTORY</b> .....	<b>3</b>
<b>2. PURPOSE</b> .....	<b>4</b>
2.1 USAGE .....	4
2.2 RELATED DOCUMENTS .....	4
<b>3. MPU-9150 9-AXIS EV BOARD OVERVIEW</b> .....	<b>5</b>
3.1 MPU-9150 KEY FUNCTION AND PIN-OUTS .....	6
3.2 MPU-9150 BUS CONNECTION .....	6
<b>4. SCHEMATIC</b> .....	<b>7</b>
<b>5. BILL OF MATERIALS</b> .....	<b>8</b>
<b>6. POWER SUPPLY CONNECTIONS</b> .....	<b>9</b>
6.1 JP4 – VLOGIC SELECTION HEADER .....	9
6.2 JP8 – POWER SELECTION HEADER .....	9
<b>7. MPU-9150 EVB CONNECTOR SIGNALS DESCRIPTION</b> .....	<b>10</b>
7.1 JP11 – EXTENDED FACTORY HEADER .....	10
7.2 JP12 – CUSTOMER HEADER CONNECTOR .....	11
7.3 CONNECTING THE FSYNC LINE .....	12
7.4 SERIAL BUS LEVELS, SPEEDS AND TERMINATIONS .....	12
<b>8. DATA GATHERING OPTIONS</b> .....	<b>13</b>
8.1 CONNECTION TO THE INV-ARMEVB .....	13
8.2 USE OF MPU-9150 WITHOUT INV-ARMEVB .....	13
<b>9. LAYOUT</b> .....	<b>14</b>
9.1 COMPONENT REFERENCE NAMES AND LOCATIONS .....	14
<b>10. SPECIAL INSTRUCTIONS: ELECTROSTATIC DISCHARGE SENSITIVITY</b> .....	<b>14</b>



## 1. Revision History

Date	Revision	Description
05/11/2011	1.0	Initial release

## 2. Purpose

This document describes the hardware and circuitry on the MPU-9150™ 9-Axis Evaluation Board (EVB). This EVB is used to evaluate the MPU-9150. The document covers (1) how to apply the EVB to a larger system, (2) understanding key signals and circuit functions, (3) hardware jumper settings, and (4) port connector descriptions.

### 2.1 Usage

This evaluation board is used to demonstrate InvenSense's MPU-9150 for 9-Axis motion detection and measurement. These 9 axes are comprised of the following:

- Digital-output X-, Y-, Z-Axis angular rate sensors (gyroscopes) with a user-programmable full-scale range of  $\pm 250$ ,  $\pm 500$ ,  $\pm 1000$ , and  $\pm 2000$  °/sec
- Digital-output X-, Y-, Z-Axis accelerometers with a programmable full scale range of  $\pm 2g$ ,  $\pm 4g$ ,  $\pm 8g$  and  $\pm 16g$
- Digital-output X-, Y-, Z-Axis magnetometer (compass) with a full scale range of  $\pm 1200\mu T$

Nine axis motion is measured using on-chip ADCs and transmitted through the MPU-9150's primary I<sup>2</sup>C interface. The user can use the primary I<sup>2</sup>C serial communications interface for standalone testing of the evaluation board. Alternatively, by connecting the EVB to the InvenSense ARM Evaluation Board (INV-ARMEVB), the user can connect the evaluation board to a host Windows PC via a USB interface. Figure 4 shows the MPU-9150 9-Axis Evaluation Board and the INV-ARMEVB connected together.

When this evaluation board is connected to a host Windows PC through the INV-ARMEVB's USB interface, the MPU-9150's motion processing capabilities can be demonstrated through motion related application software.

InvenSense provides a software package for evaluating the MPU-9150 by using the MPU-9150 EV Board. The InvenSense PC Demo Software Package, along with the Installation and User Guide for PC Demo Software for Windows can be found in the InvenSense Developers Corner (<http://www.invensense.com/developers/>).

The MPU-9150 Evaluation Board is designed to give the user easy access to key signals and configuration pins.

### 2.2 Related Documents

The following resources are recommended for a more comprehensive understanding of the components and systems described in this User Guide. These documents and packages can be found in the InvenSense Developers Corner within the InvenSense website.

- MPU-9150 Product Specification
- MPU-9150 Register Map and Register Descriptions
- Installation and User Guide for PC Demo Software for Windows
- InvenSense PC Demo Software Package

### 3. MPU-9150 9-Axis EV Board Overview

The MPU-9150 9-Axis EV Board is a fully tested evaluation board for the MPU-9150 digital Motion Processing Unit™ (MPU™). It contains a number of ‘solder-across’ jumper points that permit several circuit configurations. For ease of measurement access, the EV Board is populated only on its top side. Figure 1 shows each of these connectors.

The 10x2 Customer Header Connector (JP12) is designed to connect with the InvenSense ARM Evaluation Board (INV-ARMEVB). The INV-ARMEVB is a host microcontroller board used to connect the MPU-9150 9-Axis EV Board to a host Windows PC via a USB port.

The 5x2 Extended Factory Connector (JP11) is used to connect additional host application devices to the EV Board. For instance, a camera image stabilization processor can be connected to the MPU-9150 by using JP11. Please note that such devices should act as a master to the MPU-9150.

The 3-pin Power Selection Header (JP8) is used to select which voltage supply is fed to the MPU-9150. The 3-pin VLOGIC Selection Header (JP4) is used to select between 3 V and VIN as the logic supply voltage.

For further information regarding the power supply connections, please refer to Section 6.

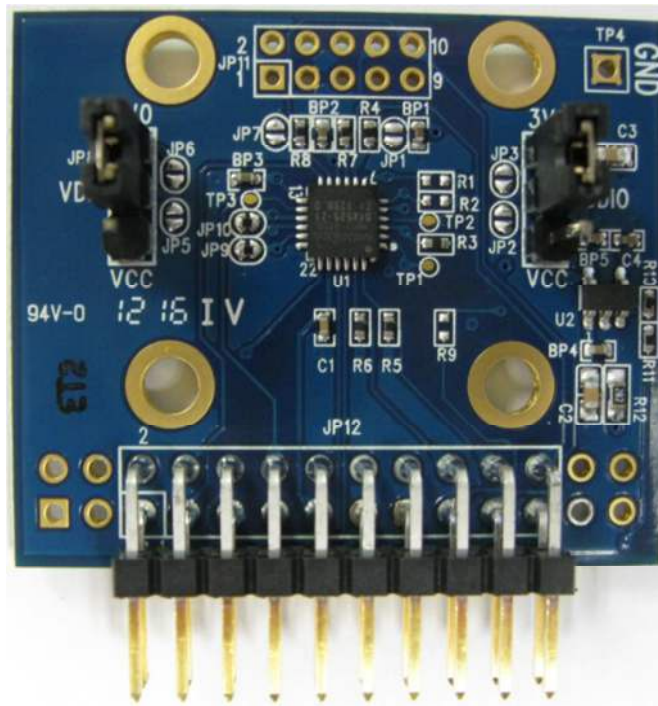

Figure 1: Top side of the MPU-9150 9-Axis EV Board

### 3.1 MPU-9150 Key Function and Pin-outs

InvenSense's MPU-9150 is used on the MPU-9150 EVB.

The MPU-9150 has an embedded 3-axis MEMS gyroscope, 3-axis MEMS accelerometer, 3-axis MEMS magnetometer and Digital Motion Processor™ (DMP) hardware accelerator engine. 9-axis MotionFusion™ combines acceleration and rotational motion plus heading information into a single data stream for an application. The MPU-9150's primary I<sup>2</sup>C interface is used to communicate with the system processor.

The MPU-9150's auxiliary I<sup>2</sup>C port is used to communicate with third party digital sensors such as pressure sensors, but is not supported on this USB Reference Board.

The MPU-9150 uses InvenSense's proprietary MEMS technology to produce a functionally complete, low-cost motion processor. All required conditioning electronics are integrated into a single package measuring 4mm x 4mm x 0.95mm. It incorporates X-, Y-, and Z-axis low-pass filters and an EEPROM for on-chip factory calibration of the sensors. A built-in Proportional-To-Absolute-Temperature (PTAT) sensor provides temperature compensation information. The product is lead-free and Green Compliant.

Figure 2 shows the MPU-9150's pins as well as its motion detection directions.

**Note:** The orientation and polarity of the magnetometer detection axes differ from those of the gyroscope and accelerometer.

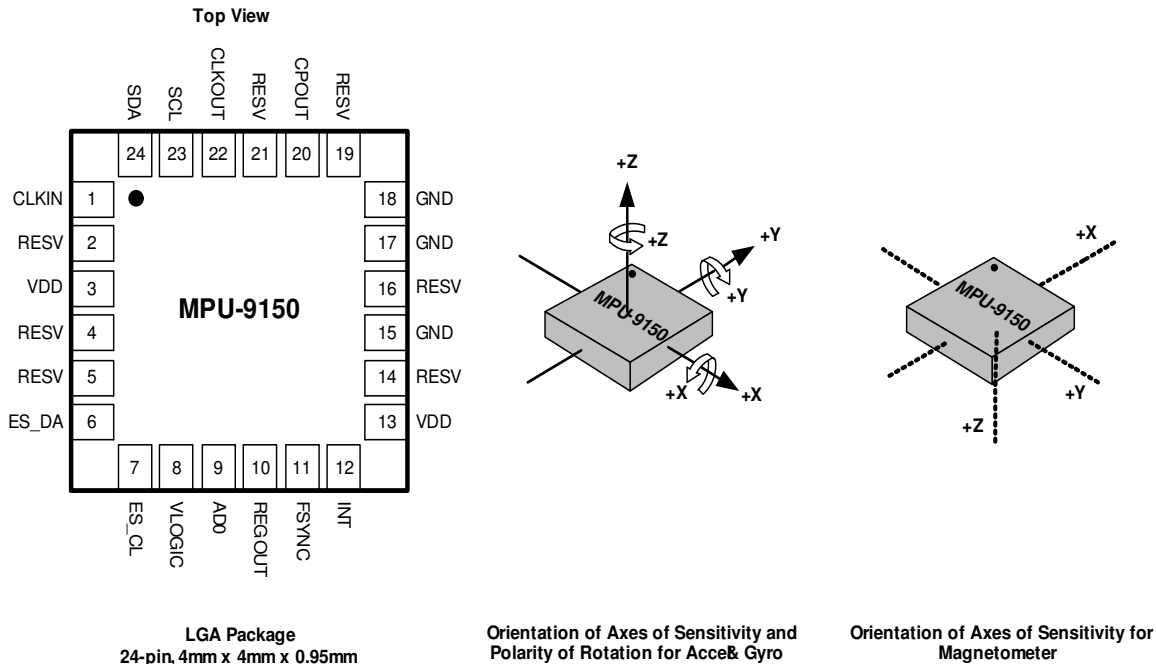

**Figure 2: MPU-9150 LGA Package (Top View) & Gyro, Accel, and Magnetometer Sense Direction**

### 3.2 MPU-9150 Bus Connection

The MPU-9150 EVB communicates to a system processor through the JP12 Customer Header Connector using the I<sup>2</sup>C serial communication interface. The device always acts as a slave when communicating to the system processor.

### 4. Schematic

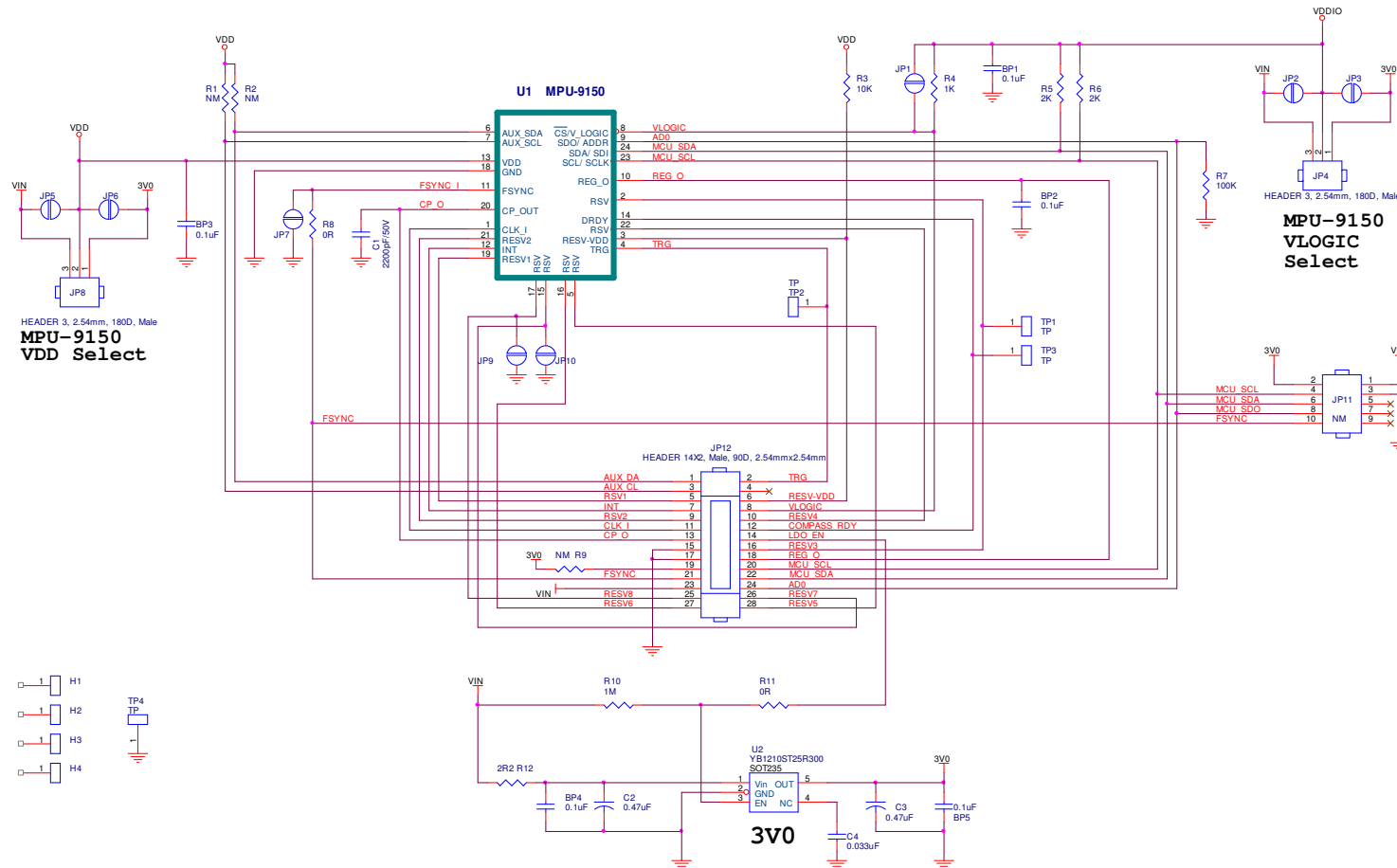

Figure 3: Schematic Diagram of the MPU-9150 EV Board



## 5. Bill of Materials

This section describes the Bill of Materials included in the MPU-9150 EV Board.

**Table 1: Bill of Materials**

Item	Quantity	Reference	Part	PCB Footprint
1	5	BP1,BP2,BP3,BP4,BP5	0.1uF	C0402
2	1	C1	2200pF/50V	C0402
3	2	C3,C2	0.47uF	C0603
4	1	C4	0.033uF	C0402
7	2	JP4,JP8	HEADER 3, 2.54mm, 180D, Male	SIP-3P
9	1	JP12	HEADER 14X2, Male, 90D, 2.54mmx2.54mm	HDB2X14NRA
11	1	R3	10K	R0402
12	1	R4	1K	R0402
13	2	R6,R5	2K	R0402
14	1	R7	100K	R0402
15	2	R8,R11	0R	R0402
16	1	R10	1M	R0402
17	1	R12	2R2	R0603
19	1	U1	MPU-9150	LGA24_4x4(0.5pitch)
20	1	U2	YB1210ST25R300	SOT235

**Table 2: Bill of Materials - Not Mounted**

Item	Quantity	Reference	Part	PCB Footprint
10	4	R1,R2,R9, JP11	NM	varies



## 6. Power Supply Connections

The JP4 VLOGIC Selection Header and JP8 Power Selection Header are 3 header-pin plug-in jumpers which allow users to select between the on-board LDO (Low-dropout voltage regulator) and an external DC supply for powering the MPU-9150. Please refer to Sections 6.1 and 6.2 for further information.

The on-board 3.0V LDO is a low-noise LDO. Its output is labeled as 3V0 in the schematic diagram in Section 4. Using this on-board LDO will assure that the gyroscope, accelerometer, and magnetometer performance will meet intended specifications.

The raw VIN line is generally selected to power the chip when designing and evaluating an embedded platform, where the host processor and related electronics need full control over the motion processing chipset's power supply.

When the on board LDO 3V0 power source is used, the external VIN must be provided with at least 3.7V in order to ensure that the LDO works properly.

If the user provides the VIN with 5V, JP4 and JP8 must be set as "1-2 short". This is because the MPU-9150's VDD and VLOGIC operation range is 2.1V to 3.6V.

### 6.1 JP4 – VLOGIC Selection Header

The 3-pin VLOGIC Selection Header (JP4) is used to select between 3 V and VIN as the logic supply voltage. Table 3 below describes the details of voltage selection for JP4.

**Table 3: JP4 - VLOGIC Selection Header**

JP4 Pin Number	Signal description
1-2 short	MPU-9150 VLOGIC = 3V (Taken from LDO. VIN must be greater than 3.7 V)
2-3 short	MPU-9150 VLOGIC = VIN (Taken from external source)

### 6.2 JP8 – Power Selection Header

The 3-pin Power Selection Header (JP8) is used to select which voltage supply is fed to the MPU-9150. Table 4 below describes the details of voltage selection for JP8.

**Table 4: Power Selection Header**

JP8 Pin Number	Signal description
1-2 short	MPU-9150 VDD = 3V (Taken from LDO. VIN must be greater than 3.7 V)
2-3 short	MPU-9150 VDD = VIN (Taken from external source)

## 7. MPU-9150 EVB Connector Signals Description

### 7.1 JP11 – Extended Factory Header

The 5x2 Extended Factory Connector (JP11) is used to connect additional host application devices to the EV Board. For instance, a camera image stabilization processor can be connected to the MPU-9150 by using JP11. Please note that such devices should act as a master to the MPU-9150.

Table 5 below shows the pin descriptions for JP11.

**Table 5: JP11 - Extended Factory Connector Signals**

JP11 Pin Number	Signal description
1	VIN. Power is received from ARM-7 Controller Board or an external source. VIN value can be 5V with current greater than 50mA or 3V with current greater than 50mA.
3	GND
5	NC
7	NC
9	NC
2	3V
4	MPU-9150 I <sup>2</sup> C SCL
6	MPU-9150 I <sup>2</sup> C SDA
8	MPU-9150 I <sup>2</sup> C device address selection pin AD0. When the pin value is low, the device address is 0x68. When the pin value is high, the device address is 0x69. The address value is 7bits.
10	MPU-9150 FSYNC Input

## 7.2 JP12 – Customer Header Connector

The 10x2 Customer Header Connector (JP12) is designed to connect with the InvenSense ARM Evaluation Board (INV-ARMEVB). The INV-ARMEVB is a host microcontroller board used to connect the MPU-9150 9-Axis EV Board to a host Windows PC via a USB port. Table 6 below shows the pin descriptions for JP12.

**Table 6: JP12 - Customer Header Connector Signals**

JP12 Pin Number	Signal description
1	AUX_DA
3	AUX_CL
5	Reserved
7	INT, MPU-9150 INTERRUPT output
9	Reserved
11	MPU-9150 CLK_IN, External Clock Input
13	MPU-9150 CPOUT, Charge pump Output
15	GND
17	GND
19	3V (optional)
21	MPU-9150 FSYNC Input
23	VIN. Power is received from ARM-7 Controller Board or an external source. VIN value can be 5V with current greater than 50mA or 3V with current greater than 50mA.
25	Reserved
27	Reserved
2	TRG. Compass trigger input
4	Reserved
6	Reserved. Connected to VDD on EVB.
8	MPU-9150 VLOGIC
10	Reserved
12	Compass DRDY output
14	MPU-9150 EVB on board LDO enable pin. H=enable; L=disable.
16	Reserved
18	MPU-9150 REGOUT
20	MPU-9150 I <sup>2</sup> C SCL
22	MPU-9150 I <sup>2</sup> C SDA
24	MPU-9150 I <sup>2</sup> C device address selection pin AD0. When the pin value is low, the device address is 0x68. When the pin value is high, the device address is 0x69. The address value is 7bits.
26	Reserved
28	Reserved



### 7.3 Connecting the FSYNC Line

The FSYNC line is used in a camera's image-stabilization system. It carries the FSYNC signal from the camera platform to the EV Board.

The FSYNC signal is used to synchronize the MPU-9150 serial bus transfer with the master timing set by the camera system. The MPU-9150 accepts the FSYNC input from JP11 pin-10 or JP12 pin-21.

There is no external pull-up termination for the FSYNC line.

For further information regarding MPU-9150's handling of the FSYNC signal, please refer to the MPU-9150 Product Specification document, as well as the MPU-9150 Register Map and Register Descriptions document.

### 7.4 Serial bus Levels, Speeds and Terminations

The serial bus level is VDDIO.

The MPU-9150 supports I<sup>2</sup>C communication up to a clock rate of 400kHz.

The I<sup>2</sup>C bus open drain pull up resistors are connected to VDDIO.

## 8. Data Gathering Options

The 9-Axis motion sensor data from the MPU-9150 can be accessed via the EVB's JP12 Customer Header Connector.

Alternatively, an InvenSense ARM Evaluation Board (INV-ARMEVB) may be used to connect the MPU-9150 EVB to a host Windows PC.

### 8.1 Connection to the INV-ARMEVB

A host Windows PC can communicate with the MPU-9150 through the INV-ARMEVB, which in turn is connected to the MPU-9150 9-Axis EVB. The INV-ARMEVB's USB interface is used to connect to the Windows PC.

Figure 4 demonstrates the connection between the MPU-9150 and the INV-ARMEVB. Connection between the two boards is established via the JP12 Customer Header Connector.

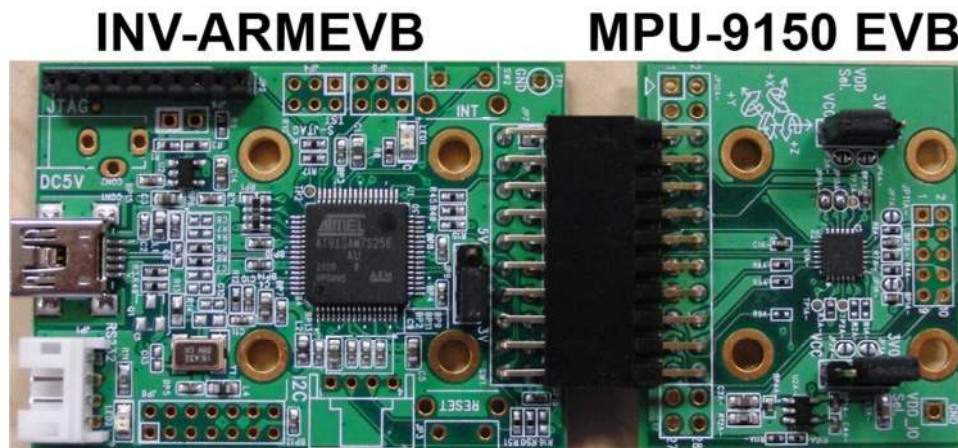

Figure 4: MPU-9150 EVB connected to ARM Board

### 8.2 Use of MPU-9150 without INV-ARMEVB

The MPU-9150's I<sup>2</sup>C signals are available at the JP11 and JP12 connectors. By utilizing these signals, the user can establish direct communication with the MPU-9150 without using the INV-ARMEVB.

There is no bus mode selection setting needed.

For JP11 and JP12 pin descriptions, please refer to Section 7.

## 9. Layout

The MPU-9150 EV board is a 4 layer PCB with 38mm x 32mm dimensions.

### 9.1 Component reference names and locations

Figures 5 and 6 show the top and bottom sides of the EVB.

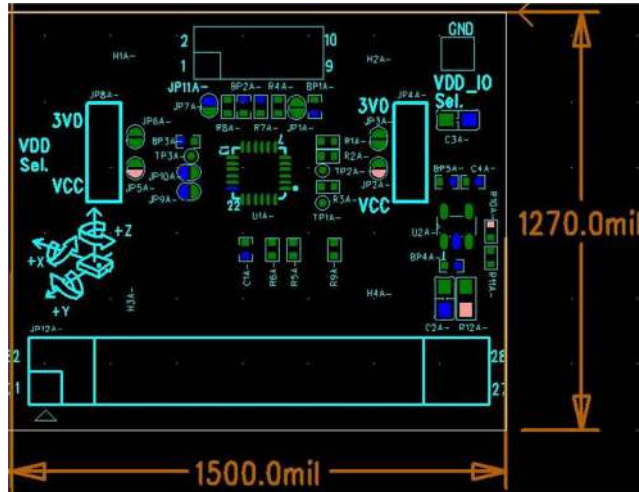

Figure 5: MPU-9150 Board Layout: Top View

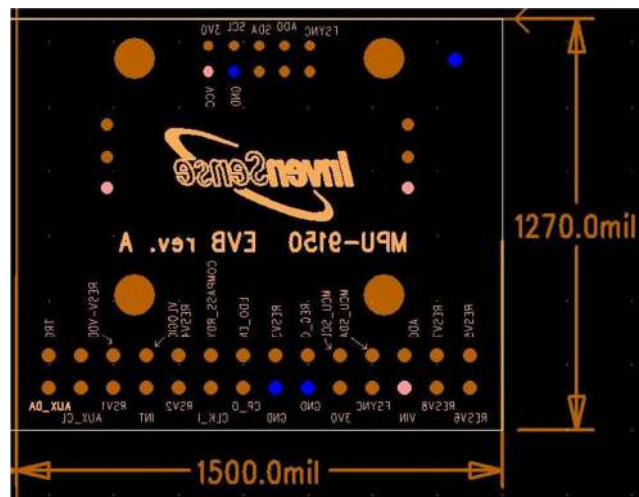

Figure 6: MPU-9150 Board Layout: Bottom View

## 10. Special Instructions: Electrostatic Discharge Sensitivity

The MPU-9150 can be permanently damaged by an electrostatic discharge. ESD precautions for handling and storage are recommended.



This information furnished by InvenSense is believed to be accurate and reliable. However, no responsibility is assumed by InvenSense for its use, or for any infringements of patents or other rights of third parties that may result from its use. Specifications are subject to change without notice. InvenSense reserves the right to make changes to this product, including its circuits and software, in order to improve its design and/or performance, without prior notice. InvenSense makes no warranties, neither expressed nor implied, regarding the information and specifications contained in this document. InvenSense assumes no responsibility for any claims or damages arising from information contained in this document, or from the use of products and services detailed therein. This includes, but is not limited to, claims or damages based on the infringement of patents, copyrights, mask work and/or other intellectual property rights.

Certain intellectual property owned by InvenSense and described in this document is patent protected. No license is granted by implication or otherwise under any patent or patent rights of InvenSense. This publication supersedes and replaces all information previously supplied. Trademarks that are registered trademarks are the property of their respective companies. InvenSense sensors should not be used or sold in the development, storage, production or utilization of any conventional or mass-destructive weapons or for any other weapons or life threatening applications, as well as in any other life critical applications such as medical equipment, transportation, aerospace and nuclear instruments, undersea equipment, power plant equipment, disaster prevention and crime prevention equipment.

InvenSense™ is a registered trademark of InvenSense, Inc.; MPU-9150™, Motion Processing Unit™, MPU™, Digital Motion Processor™, and MotionFusion™ are trademarks of InvenSense, Inc.

©2011 InvenSense, Inc. All rights reserved.

