

xTAG v3.0 Hardware Manual

IN THIS DOCUMENT

- ▶ Introduction
 - ▶ XST-U8 device
 - ▶ xSYS Connector (J2)
 - ▶ J3 and J4 connectors
 - ▶ 24MHz Crystal Oscillator
 - ▶ I/O Port-to-Pin Mapping
 - ▶ xTAG v3.0 Schematic
-

1 Introduction

The xTAG v3.0 debug adapter converts between an XMOS xSYS connector and USB 2.0, providing pins for JTAG control, system reset, processor debug, one duplex UART link and one duplex serial XMOS Link. The xTAG v3.0 debug adapter can be used to connect XMOS development kits to most PCs, and provide a 5V power supply from a USB 2.0 port.

The diagram below shows the layout of the components on the card.

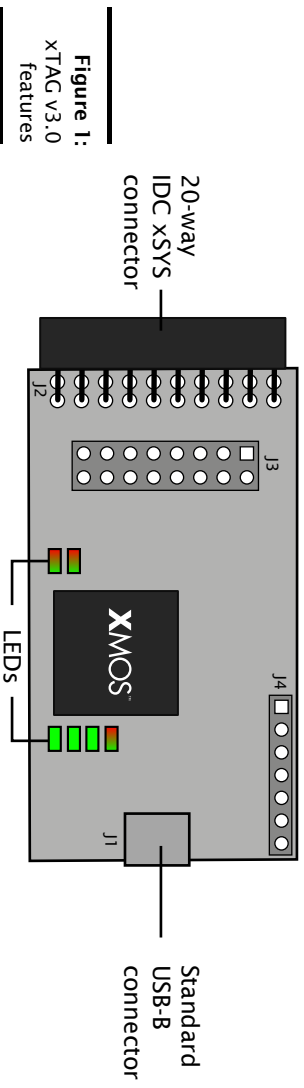

To debug a board with the xTAG v3.0 you must use xTIMEcomposer 1.3.1 or later, available from the XMOS web site: <http://xmos.com/downloads>.

The board requires an XMOS xSYS connector.

2 XSI-U8 device

The xTAG v3.0 is based on a single XSI-U8 device in a BGA package. The XSI-U8 consists of a single xCORE, which comprises a multicores microcontroller with tightly integrated general purpose I/O pins and 64 KBytes of on-chip RAM. The pins are brought out of the package and connected to the card's components as follows:

- ▶ USB Connector (U1) The xTAG v3.0 uses a Standard B-type micro USB connector to link to a PC. The USB connector is connected to the XSI-U8 device.
- ▶ xSYS 20-way IDC header

The processor has ports that are directly connected to the I/O pins. Six LEDs are driven by the debugger, their function (clockwise, starting from the power button on the bottom right):

Power	Green	The xTAG is powered on
Run	Green	Target is running
	Red	Target is in debug mode and stopped
Status	Green	Target stop reason is expected e.g. breakpoint, print message
	Red	Target stop reason is unexpected e.g. exception
Target	Green	Target device is detected after a Run Configuration or Debug Configuration is used (xrun or xgdb command)
	Red	Target device is not detected after a Run Configuration or Debug Configuration is used (xrun or xgdb command)
xSCOPE	Green Flashing	xSCOPE is enabled
	Off	No xSCOPE
JTAG	Green	There is JTAG activity with the target happening
	Off	No JTAG

3 xSYS Connector (U2)

The xTAG v3.0 includes an xSYS 20-way IDC header, which can be used to connect it to an XMOS development board for debugging programs on the hardware.

The xSYS connector provides pins for JTAG control, system reset, processor debug, a duplex UART link and a 2-bit serial xCONNECT Link.

Pin	Signal	Direction	Description
1	5V	Target to Host	Power
2	NC	N/A	No connection
3	MSEL	Host to Target	Select boot from JTAG - Active Low
4	GND	N/A	Ground
5	TDSRC	Host to Target	JTAG Test Data
6	XL1_UP1	Target to Host	xCONNECT Link
7	TMS	Host to Target	JTAG Test Mode Select
8	GND	N/A	Ground
9	TCK	Host to Target	JTAG Test Clock
10	XL1_UP0	Target to Host	xCONNECT Link
11	DEBUG	Bidirectional	Debug
12	GND	N/A	Ground
13	TDSNK	Target to Host	JTAG Test Data
14	XL1_DN0	Host to Target	xCONNECT Link
15	RST_N	Host to Target	System Reset - Active Low
16	GND	N/A	Ground
17	UART_RX	Host to Target	Serial Port
18	XL1_DN1	Host to Target	xCONNECT Link
19	UART_TX	Target to Host	Serial Port
20	GND	N/A	Ground

The routing of these I/O pins along with the power pins is shown below.

3.1 xCONNECT Link configuration

Some of the I/O pins on the processor are configured as a duplex 2-bit serial xCONNECT Link. The mapping of xCONNECT Link to the pins is shown in the table below:

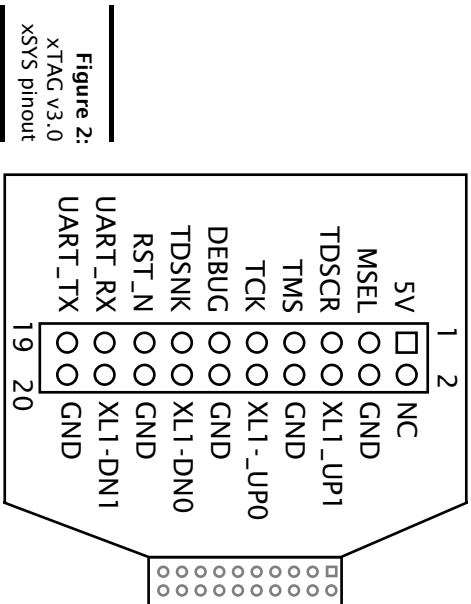

Figure 2:
XTAG v3.0
xSYS pinout

Pin	xCONNECT Link
X0D52	XL1_UP1
X0D53	XL1_UP0
X0D54	XL1_DN0
X0D55	XL1_DN1

3.2 JTAG Configuration

Some of the I/O pins on the microcontroller are driven by the JTAG signals. The mapping of the signals to the pins is shown in the table below:

Pin	Port	Processor
X0D11	P1D0	TDSRC
X0D13	P1F0	TDSNK
X0D22	P1G0	TMS
X0D10	P1C0	TCK
X0D70	P32A19	MSEL

3.3 System Reset

The system reset signal is mapped to a 1-bit port on the processor as described below. It is used as an output to reset the target processor from the debugger

Pin	Port	Processor
XOD50	P32A1	RST_N

4 J3 and J4 connectors

The xTAG v3.0 has two additional connectors. These are reserved for future use.

5 24MHz Crystal Oscillator

The XSI-U8 is clocked at 24MHz by a crystal oscillator on the card. The processor is clocked at 500MHz and the I/O ports at 100MHz, by an on-chip phase locked loop (PLL).

6 I/O Port-to-Pin Mapping

The table below provides a full description of the port-to-pin mappings described throughout this document.

Pin	Port			Processor
	1b	8b	32b	
XOD0	PIA0			UART_UP
XOD10	PIC0			TCK
XOD11	PID0			TDSRC
XOD12	PIE0			
XOD13	PIF0			TDSNK
XOD14		P8B0		LED
XOD15		P8B1		LED
XOD16		P8B2		LED
XOD17		P8B3		LED
XOD18		P8B4		LED
XOD19		P8B5		LED
XOD20		P8B6		LED
XOD21		P8B7		LED
XOD22	PIG0			TMS
XOD50		P32A1		RST_N
XOD51		P32A2		DBG
XOD52		P32A3		XL1_UP1
XOD53		P32A4		XL1_UP0
XOD54		P32A5		XL1_DN0
XOD55		P32A6		XL1_DN1
XOD69		P32A19		UART_DN
XOD70		P32A20		MSEL



Copyright © 2015, All Rights Reserved.

Xmos Ltd. is the owner or licensee of this design, code, or Information (collectively, the "Information") and is providing it to you "AS IS" with no warranty of any kind, express or implied and shall have no liability in relation to its use. Xmos Ltd. makes no representation that the Information, or any particular implementation thereof, is or will be free from any claims of infringement and again, shall have no liability in relation to any such claims.