



TwinDie™ DDR3 SDRAM

MT41J1G4 – 64 Meg x 4 x 8 Banks x 2 Ranks

MT41J512M8 – 32 Meg x 8 x 8 Banks x 2 Ranks

For component data sheets, refer to Micron's Web site: www.micron.com

Functionality

The 4Gb TwinDie™ DDR3 SDRAM uses Micron's 2Gb DDR3 die and has similar functionality. This data sheet includes key timing parameters, ball assignments, a functional description, functional block diagrams, IDD specifications, and package dimensions. Refer to Micron's 2Gb DDR3 SDRAM data sheet for complete specifications. (Specifications for base part number MT41J512M4 correlate to TwinDie manufacturing part number MT41J1G4; specifications for base part number MT41J256M8 correlate to TwinDie manufacturing part number MT41J512M8.)

Features

- Uses 2Gb Micron die
- Two ranks (includes dual CS#, ODT, CKE, and ZQ balls)
- Each rank has 8 internal banks
- $V_{DD} = V_{DDQ} = +1.5V \pm 0.075V$
- 1.5V center-terminated push/pull I/O
- JEDEC-standard ball-out
- Low-profile package
- T_C of 0°C to 95°C
 - 0°C to 85°C: 8192 refresh cycles in 64ms
 - 85°C to 95°C: 8192 refresh cycles in 32ms

Options

- Configuration
 - 64 Meg x 4 x 8 banks x 2 ranks 1G4
 - 32 Meg x 8 x 8 banks x 2 ranks 512M8
- FBGA package (lead-free)
 - 82-ball FBGA (12.5 x 15 x 1.35mm) THU Rev. A
 - 78-ball FBGA (9 x 11.5 x 1.2mm) THD Rev. D
- Timing – cycle time¹
 - 1.5ns @ CL = 10 (DDR3-1333) -15
 - 1.5ns @ CL = 9 (DDR3-1333) -15E
 - 1.87ns @ CL = 8 (DDR3-1066) -187
 - 1.87ns @ CL = 7 (DDR3-1066) -187E
 - 2.5ns @ CL = 6 (DDR3-800) -25
 - 2.5ns @ CL = 5 (DDR3-800) -25E
- Self refresh
 - Standard None
- Operating temperature
 - Commercial (0°C ≤ T_C ≤ 95°C) None
- Revision (82-ball FBGA) :A
- Revision (78-ball FBGA) :D

Notes: 1. CL = CAS (READ) latency.

Table 1: Key Timing Parameters

Speed Grade	Data Rate (MT/s)	Target ^t RCD- ^t RP-CL	^t RCD (ns)	^t RP (ns)	CL (ns)
-15	1333	10-10-10	15	15	15
-15E	1333	9-9-9	13.5	13.5	13.5
-187	1066	8-8-8	15	15	15
-187E	1066	7-7-7	13.1	13.1	13.1
-25	800	6-6-6	15	15	15
-25E	800	5-5-5	12.5	12.5	12.5

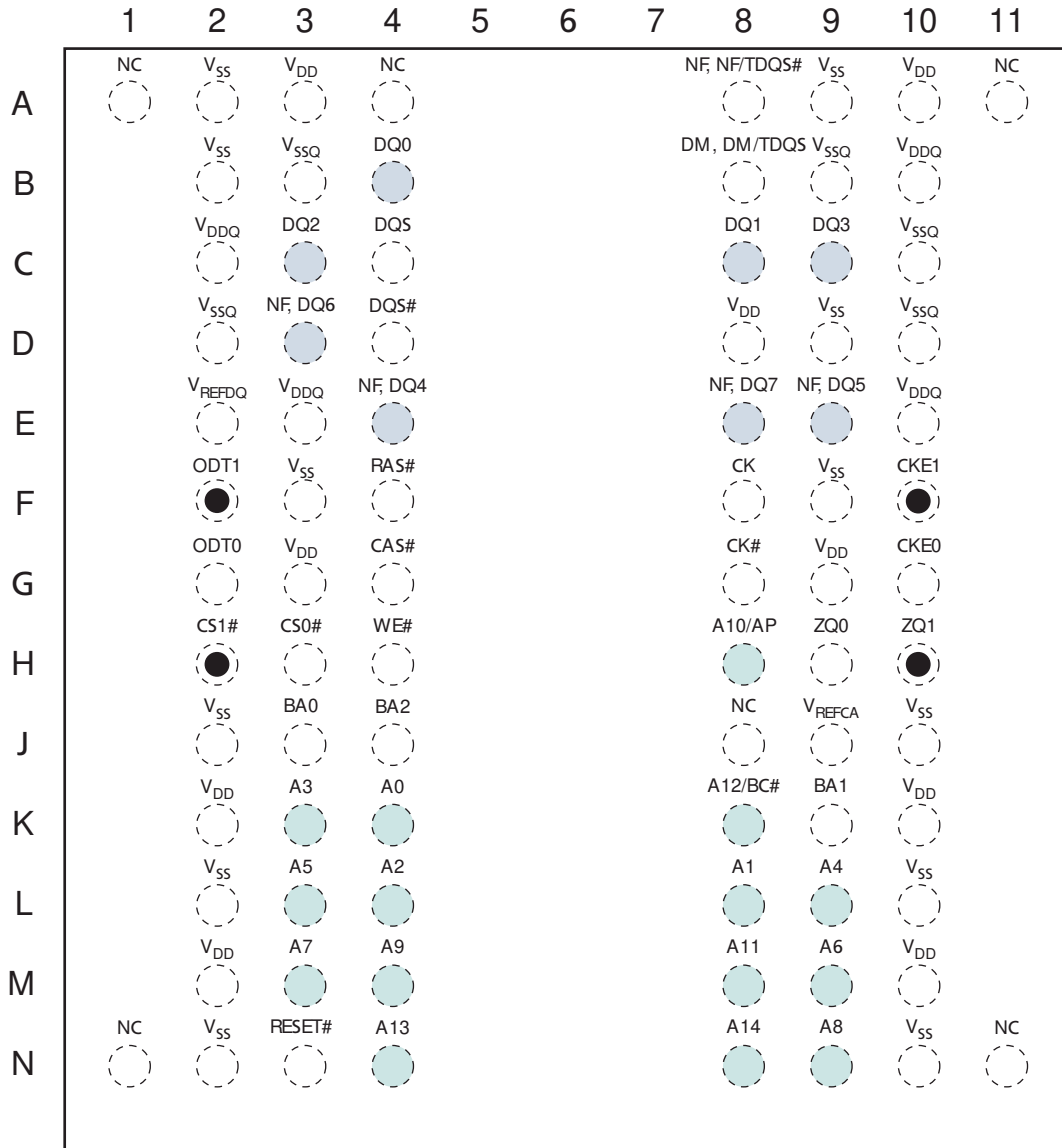

Table 2: Addressing

Parameter	1024 Meg x 4	512 Meg x 8
Configuration	64 Meg x 4 x 8 banks x 2 ranks	32 Meg x 8 x 8 banks x 2 ranks
Refresh count	8K	8K
Row address	32K A[14:0]	32K A[14:0]
Bank address	8 BA[2:0]	8 BA[2:0]
Column address	2K A[11, 9:0]	1K A[9:0]

Ball Assignments and Descriptions

Figure 1: 82-Ball FBGA Ball Assignments – Rev. A (Top View)



Notes: 1. Balls with black dots are incremental to balls on the monolithic die.

Figure 2: 78-Ball FBGA Ball Assignments – Rev. D (Top View)

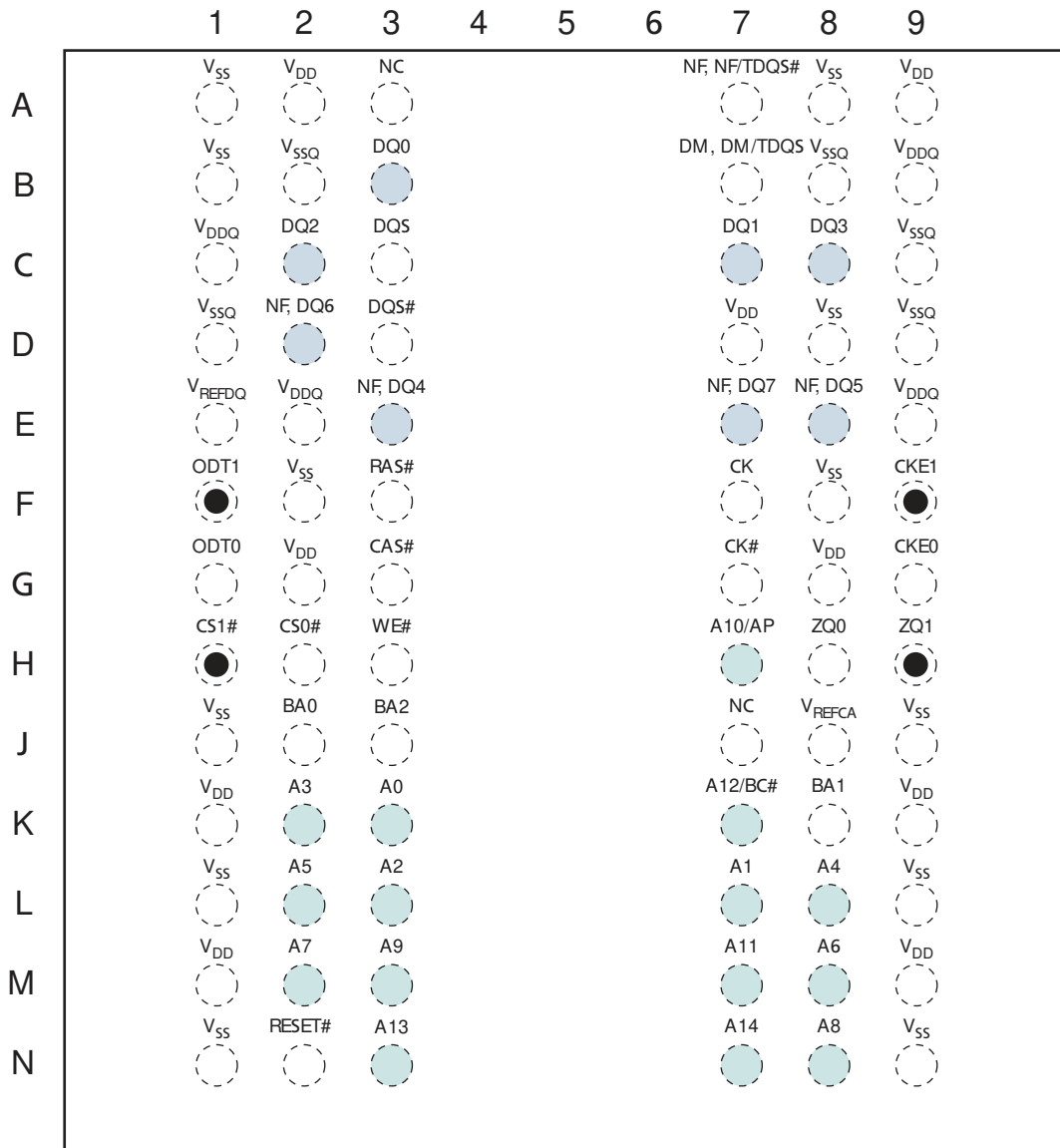

Table 3: 82-Ball and 78-Ball FBGA Ball Descriptions

Symbol	Type	Description
A14, A13, A12/BC#, A11, A10/AP, A[9:0]	Input	Address inputs: Provide the row address for ACTIVATE commands, and the column address and auto precharge bit (A10) for READ/WRITE commands, to select one location out of the memory array in the respective bank. A10 sampled during a PRECHARGE command determines whether the PRECHARGE applies to one bank (A10 LOW, bank selected by BA[2:0]) or all banks (A10 HIGH). The address inputs also provide the op-code during a LOAD MODE command. Address inputs are referenced to V_{REFCA} . A12/BC#: When enabled in the mode register (MR), A12 is sampled during READ and WRITE commands to determine whether burst chop (on-the-fly) will be performed (HIGH = burst length (BL) of 8 or no burst chop, LOW = burst chop (BC) of 4, burst chop).
BA[2:0]	Input	Bank address inputs: BA[2:0] define the bank to which an ACTIVATE, READ, WRITE, or PRECHARGE command is being applied. BA[2:0] define which mode register (MR0, MR1, MR2, or MR3) is loaded during the LOAD MODE command. BA[2:0] are referenced to V_{REFCA} .
CK, CK#	Input	Clock: CK and CK# are differential clock inputs. All control, command, and address input signals are sampled on the crossing of the positive edge of CK and the negative edge of CK#. Output data strobe (DQS, DQS#) is referenced to the crossings of CK and CK#.
CKE[1:0]	Input	Clock enable: CKE enables (registered HIGH) and disables (registered LOW) internal circuitry and clocks on the DRAM. The specific circuitry that is enabled/disabled is dependent upon the DDR3 SDRAM configuration and operating mode. Taking CKE LOW provides PRECHARGE power-down and SELF REFRESH operations (all banks idle) or active power-down (row active in any bank). CKE is synchronous for power-down entry and exit and for self refresh entry. CKE is asynchronous for self refresh exit. Input buffers (excluding CK, CK#, CKE, RESET#, and ODT) are disabled during power-down. Input buffers (excluding CKE and RESET#) are disabled during SELF REFRESH. CKE is referenced to V_{REFCA} .
CS#[1:0]	Input	Chip select: CS# enables (registered LOW) and disables (registered HIGH) the command decoder. All commands are masked when CS# is registered HIGH. CS# provides for external rank selection on systems with multiple ranks. CS# is considered part of the command code. CS# is referenced to V_{REFCA} .
DM	Input	Input data mask: DM is an input mask signal for write data. Input data is masked when DM is sampled HIGH, along with the input data, during a write access. Although the DM ball is input-only, the DM loading is designed to match that of the DQ and DQS balls. DM is referenced to V_{REFDQ} . DM has an optional use as TDQS on the x8.
ODT[1:0]	Input	On-die termination: ODT enables (registered HIGH) and disables (registered LOW) termination resistance internal to the DDR3 SDRAM. When enabled in normal operation, ODT is only applied to each of the following balls: DQ[7:0], DQS, DQS#, and DM for the x8; DQ[3:0], DQS, DQS#, and DM for the x4. The ODT input is ignored if disabled via the LOAD MODE command. ODT is referenced to V_{REFCA} .
RAS#, CAS#, WE#	Input	Command inputs: RAS#, CAS#, and WE# (along with CS#) define the command being entered and are referenced to V_{REFCA} .
RESET#	Input	Reset: RESET# is an active LOW CMOS input referenced to V_{SS} . The RESET# input receiver is a CMOS input defined as a rail-to-rail signal with $DC\ HIGH \geq 0.8 \times V_{DDQ}$ and $DC\ LOW \leq 0.2 \times V_{DDQ}$. RESET# assertion and desertion are asynchronous.
DQ[3:0]	I/O	Data input/output: Bidirectional data bus for the x4 configuration. DQ[3:0] are referenced to V_{REFDQ} .
DQ[7:0]	I/O	Data input/output: Bidirectional data bus for the x8 configuration. DQ[7:0] are referenced to V_{REFDQ} .
DQS, DQS#	I/O	Data strobe: DQS and DQS# are differential data strobes. Output with read data. Edge-aligned with read data. Input with write data. Center-aligned with write data.
TDQS, TDQS#	Output	Termination data strobe: Applies to the x8 configuration only. When TDQS is enabled, DM is disabled, and the TDQS and TDQS# balls provide termination resistance.
V_{DD}	Supply	Power supply: 1.5V \pm 0.075V.

Table 3: 82-Ball and 78-Ball FBGA Ball Descriptions (continued)

Symbol	Type	Description
V_{DDQ}	Supply	DQ power supply: 1.5V \pm 0.075V. Isolated on the device for improved noise immunity.
V_{REFCA}	Supply	Reference voltage for control, command, and address: V_{REFCA} must be maintained at all times (including self refresh) for proper device operation.
V_{REFDQ}	Supply	Reference voltage for data: V_{REFDQ} must be maintained at all times (including self refresh) for proper device operation.
V_{SS}	Supply	Ground.
V_{SSQ}	Supply	DQ ground: Isolated on the device for improved noise immunity.
ZQ[1:0]	Reference	External reference ball for output drive calibration: This ball is tied to an external 240 Ω resistor (RZQ), which is tied to V_{SSQ} .
NC	–	No connect: These balls should be left unconnected (the ball has no connection to the DRAM or to other balls).
NF	–	No function: When configured as a x4 device, these balls are NF. When configured as a x8 device, these balls are defined as TDQS#, DQ[7:4].

Functional Description

The 4Gb (TwinDie) DDR3 SDRAM is a high-speed, CMOS dynamic random access memory device containing 4,294,967,296 bits and is internally configured as two 8-bank 2Gb DDR3 SDRAM.

Although each die is tested individually within the dual-die package, some TwinDie test results may vary from a like-die tested within a monolithic die package.

The DDR3 SDRAM uses a double data rate architecture to achieve high-speed operation. The double data rate architecture is an $8n$ -prefetch architecture with an interface designed to transfer two data words per clock cycle at the I/O balls. A single read or write access consists of a single $8n$ -bit-wide, one-clock-cycle data transfer at the internal DRAM core and eight corresponding n -bit-wide, one-half-clock-cycle data transfers at the I/O balls.

The differential data strobes (DQS, DQS#) are transmitted externally, along with data, for use in data capture at the DDR3 SDRAM input receiver. DQS is center-aligned with data for WRITES. The read data is transmitted by the DDR3 SDRAM and edge-aligned to the data strobes.

Read and write accesses to the DDR3 SDRAM are burst oriented. Accesses start at a selected location and continue for a programmed number of locations in a programmed sequence. Accesses begin with the registration of an ACTIVATE command, which is then followed by a READ or WRITE command. The address bits registered coincident with the ACTIVATE command are used to select the bank and row to be accessed. The address bits (including $CSn\#$, BA_n , and A_n) registered coincident with the READ or WRITE command are used to select the rank, bank, and starting column location for the burst access.

This data sheet provides a general description, package dimensions, and the package ballout. Refer to the Micron 2Gb DDR3 data sheet for complete information regarding individual die initialization, register definition, command descriptions, and die operation.

Functional Block Diagrams

Figure 3: Functional Block Diagram (64 Meg x 4 x 8 Banks x 2 Ranks)

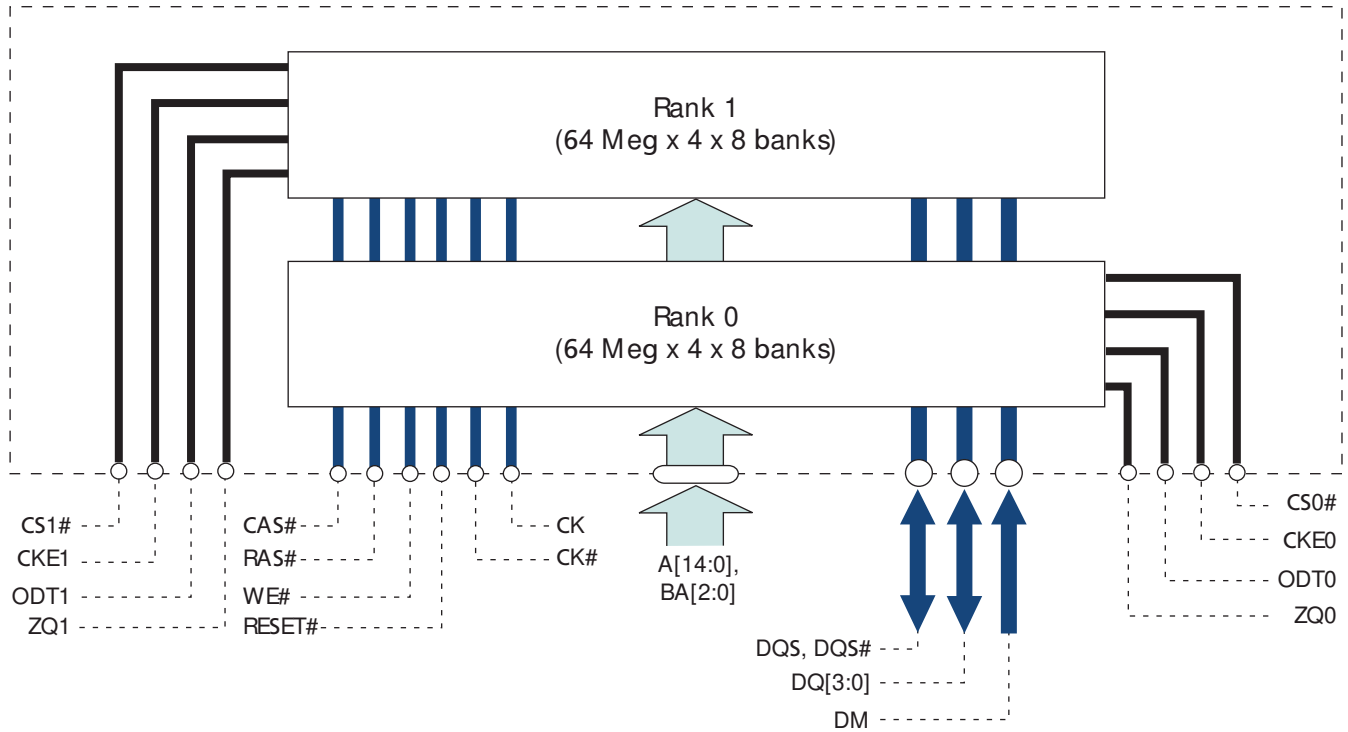
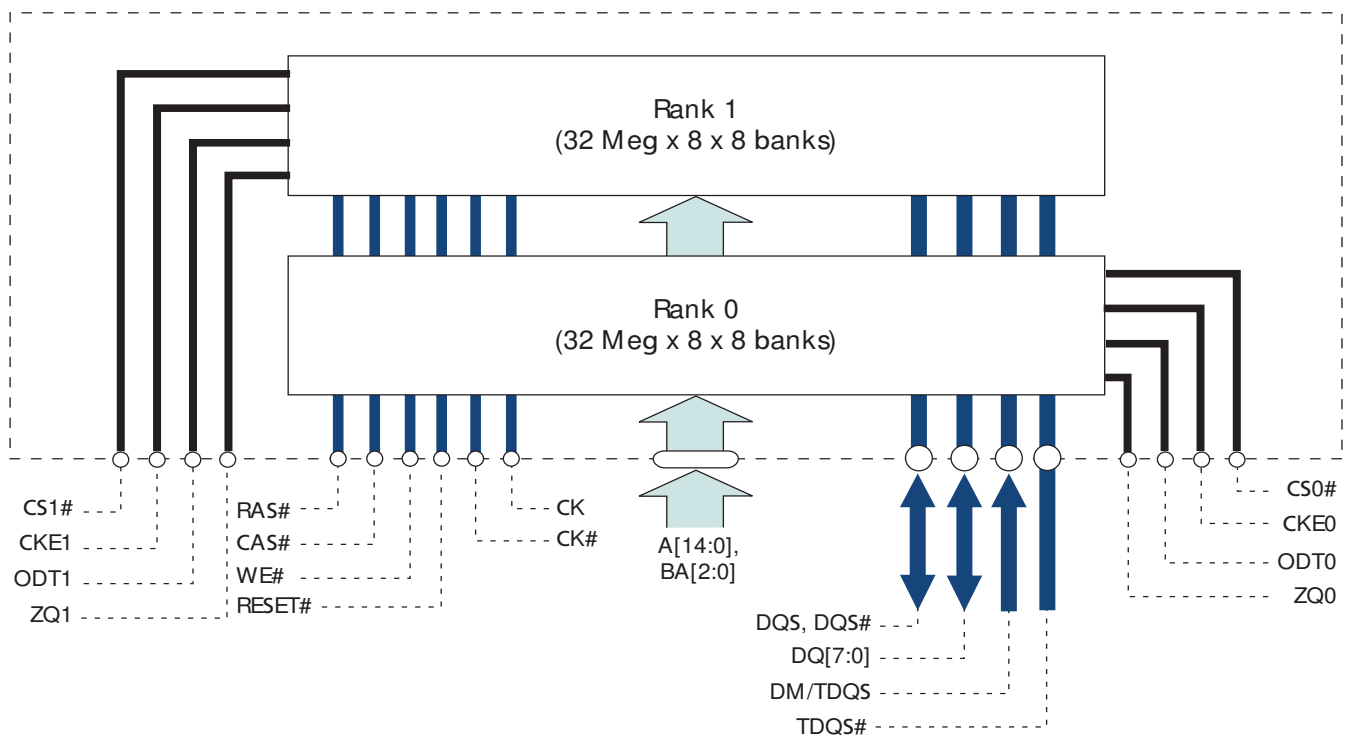

Figure 4: Functional Block Diagram (32 Meg x 8 x 8 Banks x 2 Ranks)



Electrical Specifications

Stresses greater than those listed may cause permanent damage to the device. This is a stress rating only, and functional operation of the device at these or any other conditions outside those indicated in the device data sheet is not implied. Exposure to absolute maximum rating conditions for extended periods may adversely affect reliability.

Table 4: Absolute Maximum Ratings

Symbol	Parameter	Min	Max	Units	Notes
V_{DD}	V_{DD} supply voltage relative to V_{SS}	-0.4	1.975	V	1
V_{DDQ}	V_{DDQ} supply voltage relative to V_{SSQ}	-0.4	1.975	V	
V_{IN}, V_{OUT}	Voltage on any ball relative to V_{SS}	-0.4	1.975	V	
I_I	Input leakage current Any input $0V \leq V_{IN} \leq V_{DD}$, V_{REF} pin $0V \leq V_{IN} \leq 1.1V$ (All other pins not under test = 0V)	-4	+4	μA	
I_{VREF}	V_{REF} supply leakage current $V_{REFDQ} = V_{DD}/2$ or $V_{REFCA} = V_{DD}/2$ (All other pins not under test = 0V)	-2	+2	μA	2
T_C	Operating case temperature	0	95	$^{\circ}C$	3, 4
T_{STG}	Storage temperature	-55	150	$^{\circ}C$	

- Notes: 1. V_{DD} and V_{DDQ} must be within 300mV of each other at all times, and V_{REF} must not be greater than $0.6 \times V_{DDQ}$. When V_{DD} and V_{DDQ} are less than 500mV, V_{REF} may be $\leq 300mV$.
2. The minimum limit requirement is for testing purposes. The leakage current on the V_{REF} pin should be minimal.
3. MAX operating case temperature. T_C is measured in the center of the package (see Figure 5 on page 10).
4. Device functionality is not guaranteed if the DRAM device exceeds the maximum T_C during operation.

Temperature and Thermal Impedance

It is imperative that the DDR3 SDRAM device's temperature specifications, shown in Table 5 on page 10, be maintained to ensure the junction temperature is in the proper operating range to meet data sheet specifications. An important step in maintaining the proper junction temperature is using the device's thermal impedances correctly. Thermal impedances listed in Table 6 on page 10 apply to the current die revision and packages.

Incorrectly using thermal impedances can produce significant errors. Read Micron technical note [TN-00-08: "Thermal Applications,"](#) prior to using the thermal impedances in Table 6. For designs that are expected to last several years and require the flexibility to use several DRAM die shrinks, consider using final target theta values (rather than existing values) to account for increased thermal impedances from the reduction in die size.

The DDR3 SDRAM device's safe junction temperature range can be maintained when the T_C specification is not exceeded. In applications where the device's ambient temperature is too high, use of forced air and/or heat sinks may be required to satisfy the case temperature specifications.

Table 5: Thermal Characteristics

Parameter/Condition	Symbol	Value	Units	Notes
Operating case temperature	T_C	0 to 85	°C	1, 2, 3
		0 to 95	°C	1, 2, 3, 4

- Notes:
1. MAX operating case temperature. T_C is measured in the center of the package (see Figure 5).
 2. A thermal solution must be designed to ensure the DRAM device does not exceed the maximum T_C during operation.
 3. Device functionality is not guaranteed if the DRAM device exceeds the maximum T_C during operation.
 4. If T_C exceeds 85°C, the DRAM must be refreshed externally at 2X refresh, which is a 3.9µs interval refresh rate. The use of self refresh temperature (SRT) or automatic self refresh (ASR), if available, must be enabled.

Table 6: Thermal Impedance

Die Rev	Package	Substrate	θ_{JA} (°C/W) Airflow = 0m/s	θ_{JA} (°C/W) Airflow = 1m/s	θ_{JA} (°C/W) Airflow = 2m/s	θ_{JB} (°C/W)	θ_{JC} (°C/W)	Notes
A	82-ball	2-layer	46.0	33.9	28.1	25.6	1.73	1
		4-layer	34.2	27.1	23.6			
D	78-ball	2-layer	61.0	43.7	37.3	27.1	2.8	1
		4-layer	44.5	35.3	31.5			

- Notes:
1. Thermal resistance data is based upon a number of samples from multiple lots and should be viewed as a typical number.

Figure 5: Temperature Test Point Location

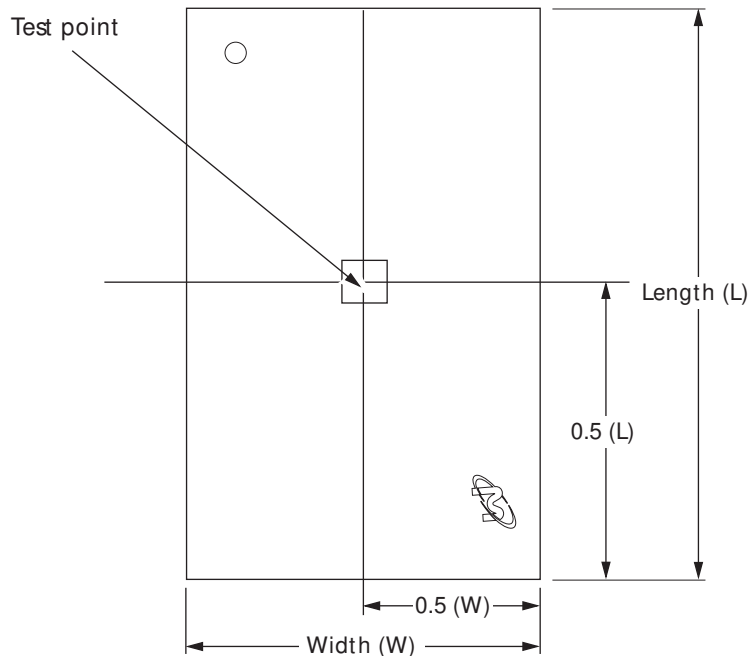

I_{DD} Specifications and Conditions

Table 7: DDR3 I_{CDD} Specifications and Conditions – Rev. A

Note 1 applies to the entire table.

Combined Symbol	Individual Die Status	Width	-25/ -25E	-187/ -187E	-15/ -15E	Units
I _{CDD0}	$I_{CDD0} = I_{DD0} + I_{DD2P0} + 5$	x4	92	107	117	mA
		x8	117	137	147	mA
I _{CDD1}	$I_{CDD1} = I_{DD1} + I_{DD2P0} + 5$	x4	117	132	147	mA
		x8	132	152	172	mA
I _{CDD2P0} (slow exit)	$I_{CDD2P0} = I_{DD2P0} + I_{DD2P0}$	x4/x8	24	24	24	mA
I _{CDD2P1} (fast exit)	$I_{CDD2P1} = I_{DD2P1} + I_{DD2P0}$		42	47	52	mA
I _{CDD2Q}	$I_{CDD2Q} = I_{DD2Q} + I_{DD2P0}$	x4/x8	67	77	87	mA
I _{CDD2N}	$I_{CDD2N} = I_{DD2N} + I_{DD2P0}$	x4/x8	72	82	92	mA
I _{CDD2NT}	$I_{CDD2NT} = I_{DD2NT} + I_{DD2P0}$		77	87	97	mA
I _{CDD3P}	$I_{CDD3P} = I_{DD3P} + I_{DD2P0}$	x4/x8	62	67	77	mA
I _{CDD3N}	$I_{CDD3N} = I_{DD3N} + I_{DD2P0}$	x4/x8	82	92	107	mA
I _{CDD4W}	$I_{CDD4W} = I_{DD4W} + I_{DD2P0} + 5$	x4	212	242	272	mA
		x8	277	312	347	mA
I _{CDD4R}	$I_{CDD4R} = I_{DD4R} + I_{DD2P0} + 5$	x4	192	217	247	mA
		x8	212	242	272	mA
I _{CDD5B}	$I_{CDD5B} = I_{DD5B} + I_{DD2P0}$	x4/x8	287	302	317	mA
I _{CDD6}	$I_{CDD6} = I_{DD6} + I_{DD6}$	x4/x8	20	20	20	mA
I _{CDD6ET}	$I_{CDD6ET} = I_{DD6ET} + I_{DD6ET}$	x4/x8	28	28	28	mA
I _{CDD7}	$I_{CDD7} = I_{DD7} + I_{DD2P0} + 5$	x4	337	362	432	mA
		x8	417	447	477	mA
I _{CDD8}	$I_{CDD8} = 2 \times I_{DD2P0} + 4$	All	28	28	28	mA

 Notes: 1. I_{CDD} values reflect the combined current of both individual die. I_{DDx} represents individual die values.

Table 8: DDR3 I_{CDD} Specifications and Conditions – Rev. D

Note 1 applies to the entire table.

Combined Symbol	Individual Die Status	Width	-187/ -187E	-15/ -15E	Units
I _{CDD0}	$I_{CDD0} = I_{DD0} + I_{DD2P0} + 5$	x4	82	87	mA
		x8	82	87	mA
I _{CDD1}	$I_{CDD1} = I_{DD1} + I_{DD2P0} + 5$	x4	102	107	mA
		x8	102	107	mA
I _{CDD2P0} (slow exit)	$I_{CDD2P0} = I_{DD2P0} + I_{DD2P0}$	x4/x8	24	24	mA
I _{CDD2P1} (fast exit)	$I_{CDD2P1} = I_{DD2P1} + I_{DD2P0}$		32	37	mA
I _{CDD2Q}	$I_{CDD2Q} = I_{DD2Q} + I_{DD2P0}$	x4/x8	42	47	mA
I _{CDD2N}	$I_{CDD2N} = I_{DD2N} + I_{DD2P0}$	x4/x8	44	49	mA
I _{CDD2NT}	$I_{CDD2NT} = I_{DD2NT} + I_{DD2P0}$		52	57	mA
I _{CDD3P}	$I_{CDD3P} = I_{DD3P} + I_{DD2P0}$	x4/x8	42	47	mA
I _{CDD3N}	$I_{CDD3N} = I_{DD3N} + I_{DD2P0}$	x4/x8	47	52	mA
I _{CDD4W}	$I_{CDD4W} = I_{DD4W} + I_{DD2P0} + 5$	x4	147	167	mA
		x8	147	167	mA
I _{CDD4R}	$I_{CDD4R} = I_{DD4R} + I_{DD2P0} + 5$	x4	142	162	mA
		x8	142	162	mA
I _{CDD5B}	$I_{CDD5B} = I_{DD5B} + I_{DD2P0}$	x4/x8	202	217	mA
I _{CDD6}	$I_{CDD6} = I_{DD6} + I_{DD6}$	x4/x8	24	24	mA
I _{CDD6ET}	$I_{CDD6ET} = I_{DD6ET} + I_{DD6ET}$	x4/x8	30	30	mA
I _{CDD7}	$I_{CDD7} = I_{DD7} + I_{DD2P0} + 5$	x4	287	337	mA
		x8	287	337	mA
I _{CDD8}	$I_{CDD8} = 2 \times I_{DD2P0} + 4$	All	28	28	mA

 Notes: 1. I_{CDD} values reflect the combined current of both individual die. I_{DDx} represents individual die values.

Package Dimensions

Figure 6: 82-Ball FBGA Package Dimensions – Rev. A

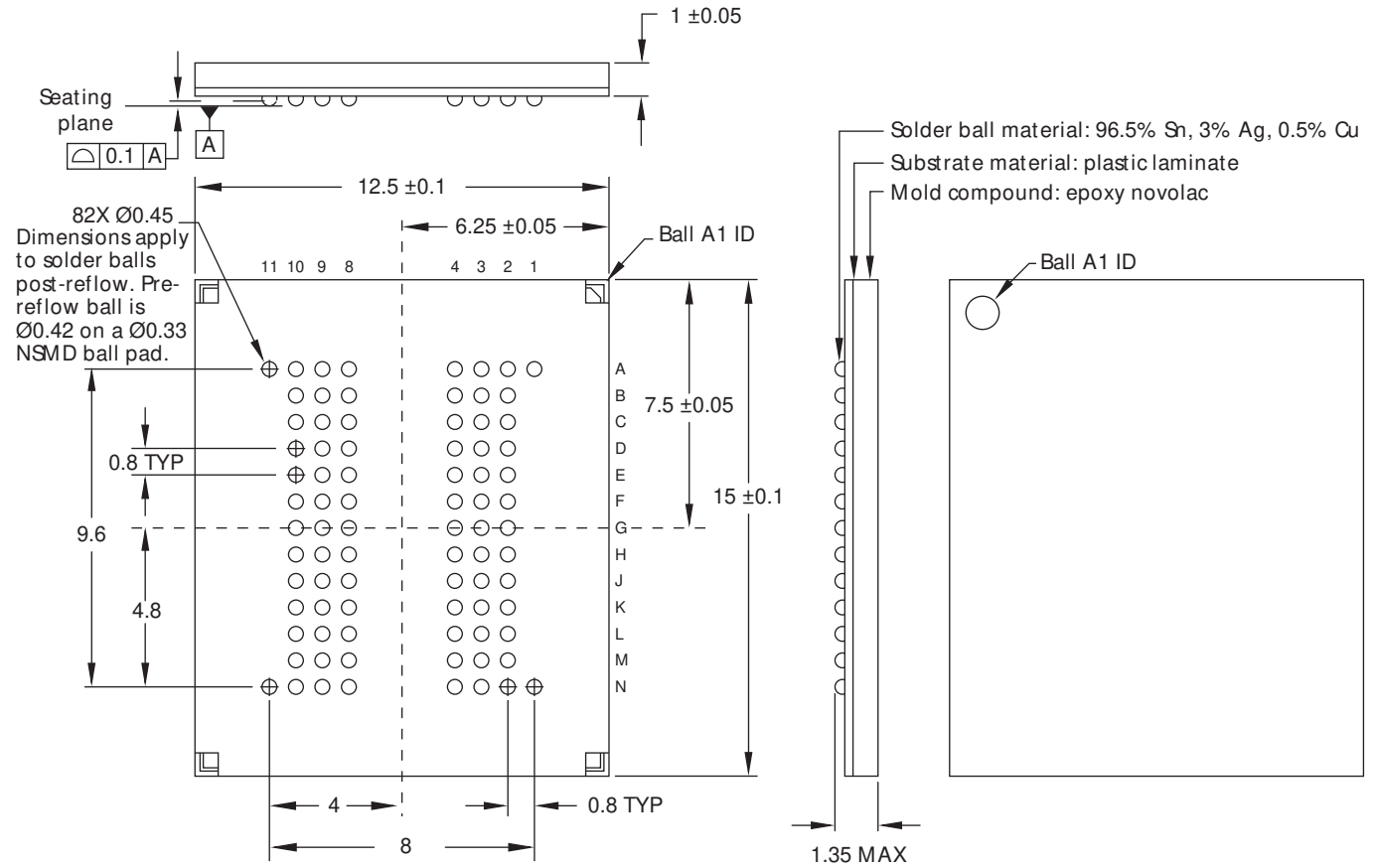

Note: All dimensions are in millimeters.

Figure 7: 78-Ball FBGA Package Dimensions – Rev. D

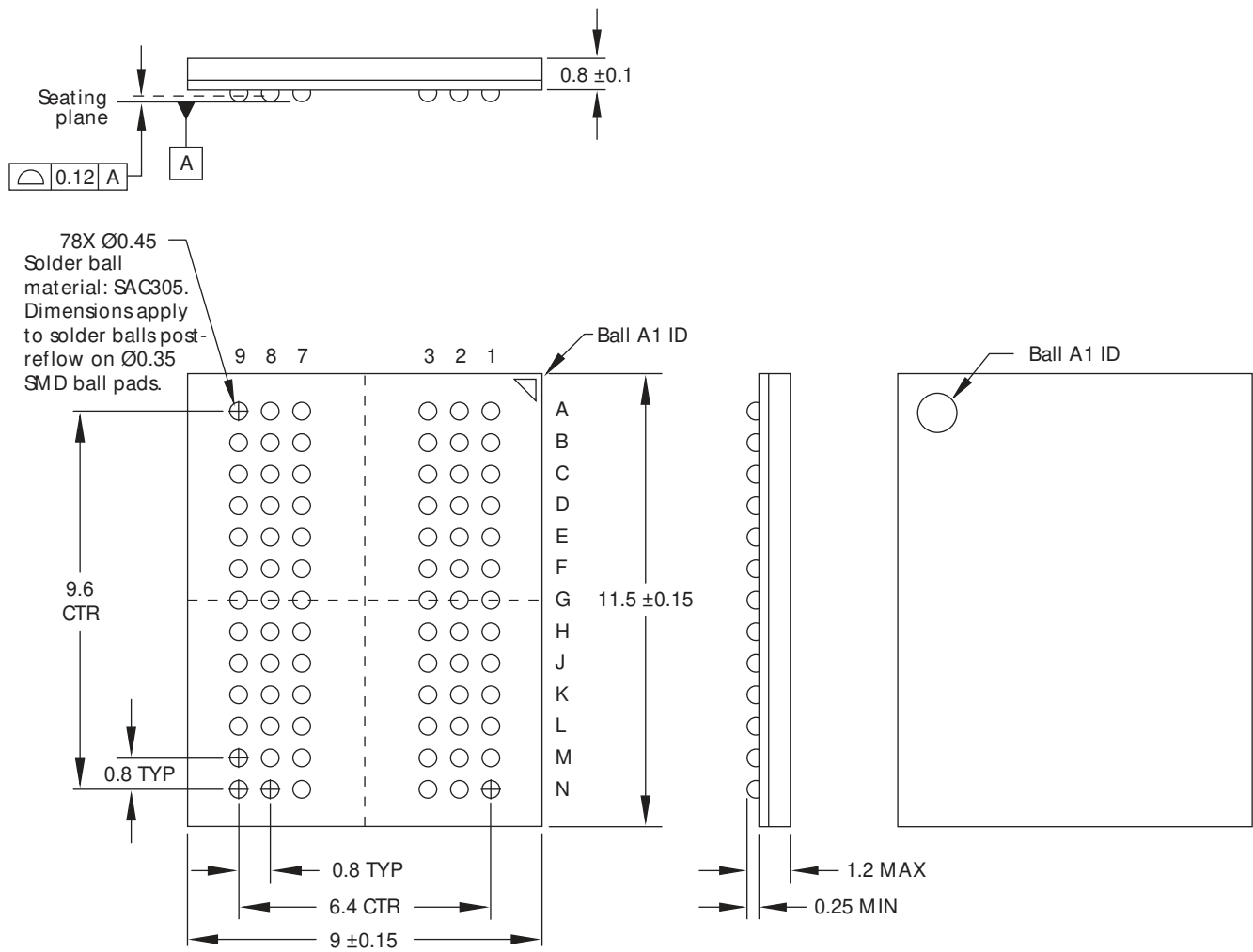

Note: All dimensions are in millimeters.

8000 S. Federal Way, P.O. Box 6, Boise, ID 83707-0006, Tel: 208-368-3900
www.micron.com/productsupport Customer Comment Line: 800-932-4992
 Micron, the Micron logo, and TwinDie are trademarks of Micron Technology, Inc.
 All other trademarks are the property of their respective owners.

This data sheet contains minimum and maximum limits specified over the power supply and temperature range set forth herein. Although considered final, these specifications are subject to change, as further product development and data characterization sometimes occur.