

THIS COPY IS PROVIDED ON A RESTRICTED BASIS AND IS NOT TO BE USED IN ANY WAY DETRIMENTAL TO THE INTERESTS OF PANDUIT CORP.

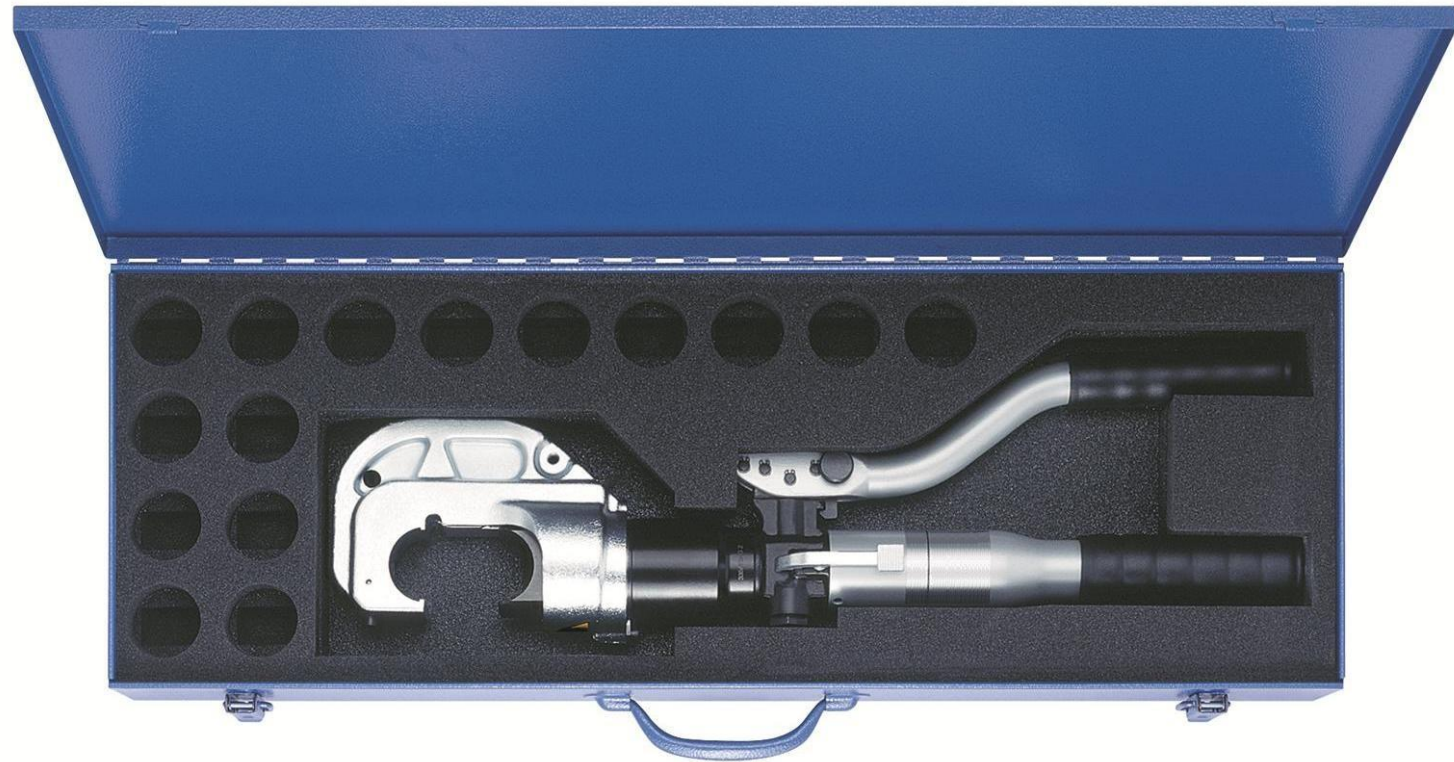

\*NOTE: CT-920 SHOWN IN PICTURES. CT-920/CV NOT SHOWN.

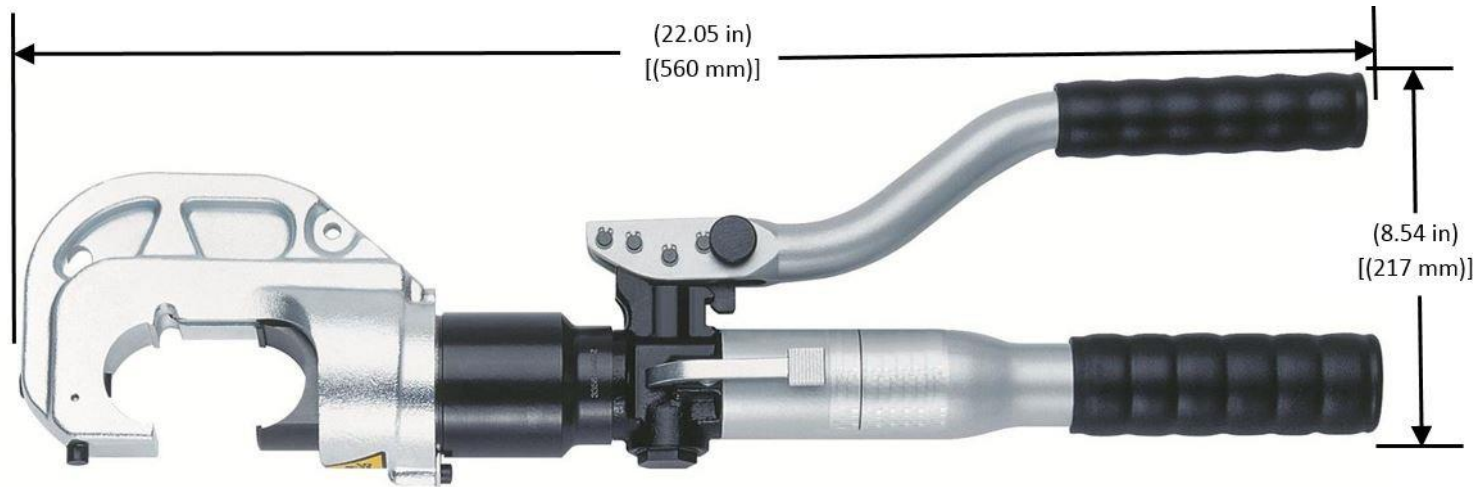

CT-920 • CT-920/CV  
CRIMP TOOLS

**NOTES, UNLESS OTHERWISE SPECIFIED:**

The CT-920 and CT-920/CV Hand Operated Hydraulic Crimping Tools are designed to crimp:

- Crimps Panduit Copper and Aluminum compression connectors using Panduit Crimping Dies. Go to [www.panduit.com](http://www.panduit.com) for information.

**The CT-920 Tool includes:**

Qty.	Description / Item
1	Hand Operated Hydraulic Crimp Tool
1	Steel Tool Case with Crimp Die Storage

**The CT-920/CV Tool includes:**

Qty.	Description / Item
1	Hand Operated Hydraulic Crimp Tool with Dual-Layer PVC Covered Crimp Head
1	Steel Tool Case with Crimp Die Storage

**Technical Information:**

Tool Weight	13.9 lbs. (6.3 kg)
Dimensions	22.1" L x 8.5" H x 2.91" W [560 L x 217 H x 74 W] mm
Crimping Force	12 tons (108 kN)

Tools are to be used with Panduit crimp dies, and are sold separately. Go to [www.panduit.com](http://www.panduit.com) for more information.

Copy of the operation manual and accessory information can be found at: [www.panduit.com](http://www.panduit.com).

Dimensions in [brackets] are in millimeters. All dimensions are for reference only.

REV	DATE	BY	CHK	APR	DESCRIPTION	ECN	CT-920 and CT-920/CV					
							CUSTOMER DRAWING					
							ITEM REVISION NAME: 00084SLM_DC/00		<b>PANDUIT</b>			
							UNLESS OTHERWISE SPECIFIED, DIMENSIONAL TOLERANCES ARE: (.x) ± --- (.xxx) ± --- (.xx) ± --- ANGLES ± ---					
							THIRD ANGLE PROJECTION		MATERIAL: -----			
00	7-25-16	BKA	ACC	JADE	DRAWING RELEASED	010062	DRAWN BY: BKA		DATE: 7-21-16		SCALE: NONE	
							CHK ACC		DRAWING NUMBER: 00084SLM_DC		SHT 1 OF 1	
							SIZE B					