

LOC	DIST	REVISIONS			
P	LT#	DESCRIPTION	DATE	OWN	APVD
A3		Released as per ECR-08-011918	12.May.2008	SP	TS
A4		REVISED PER ECR-16-016768	24.JAN.2018	SRG	MKO

- NOTES
- 1 Material: Housing: aluminium diecasting alloy
  - 2 Surface:- -Powder varnish grey  
-Aluminium oxide+  
-Varnish black
  - 3 Varnish on the inside not necessary
  - 4 Packaging  
Packaging quantity 5 pieces in a box

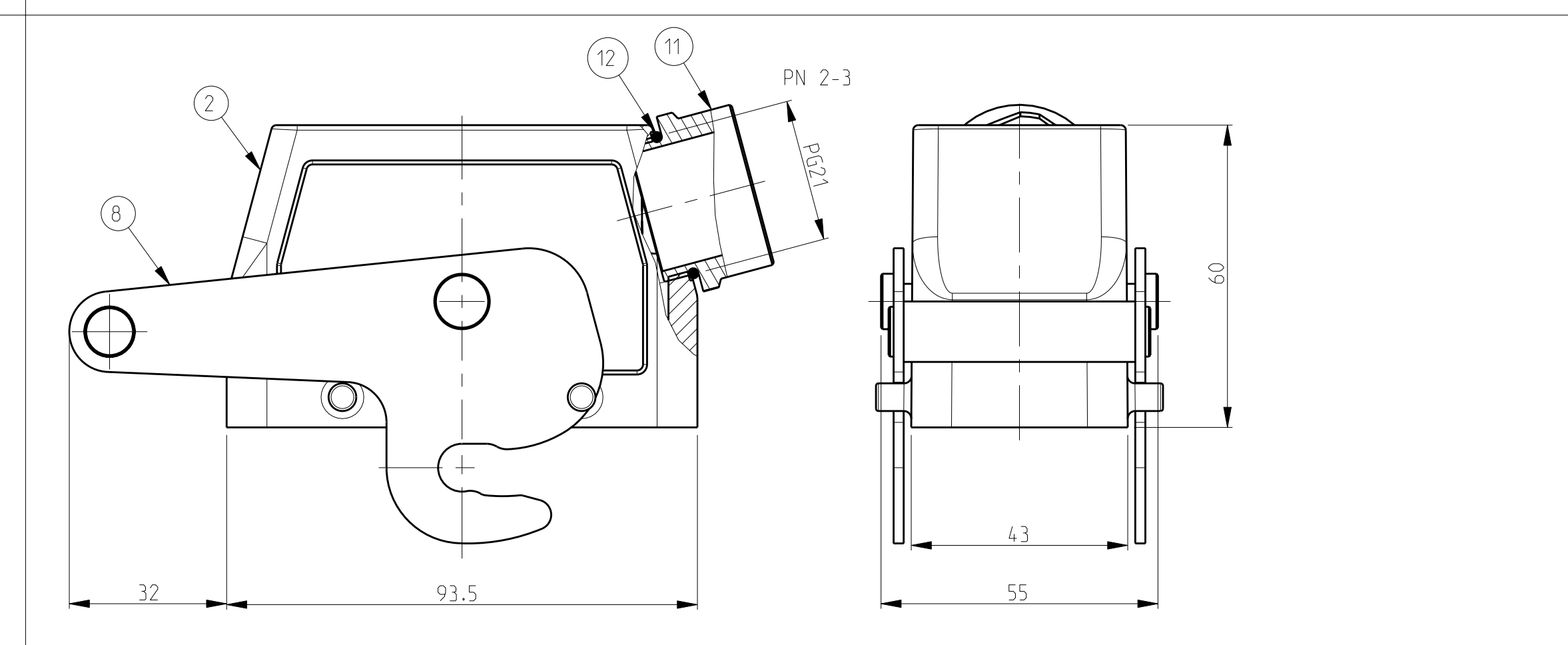
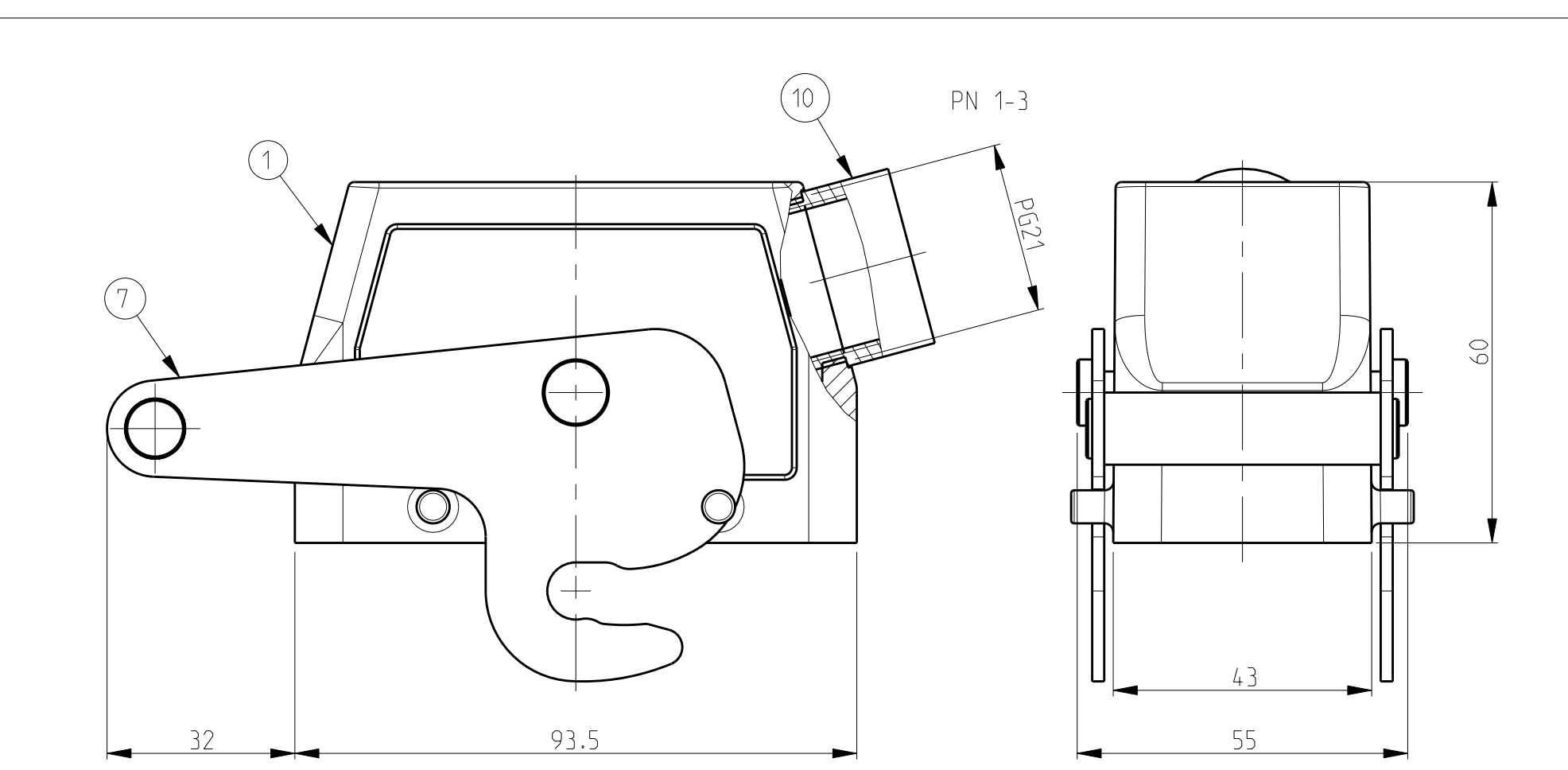
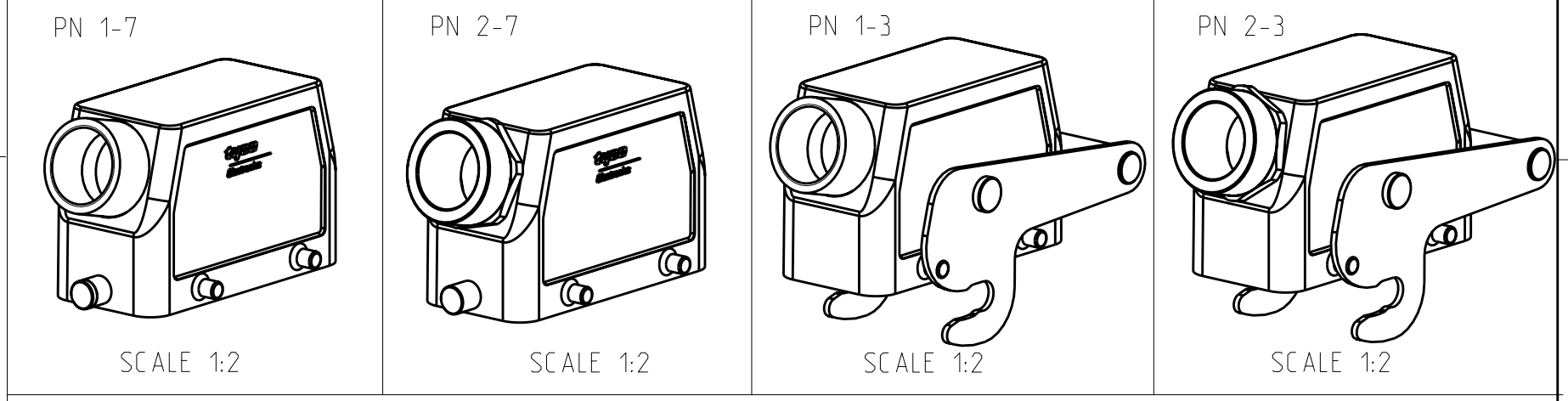
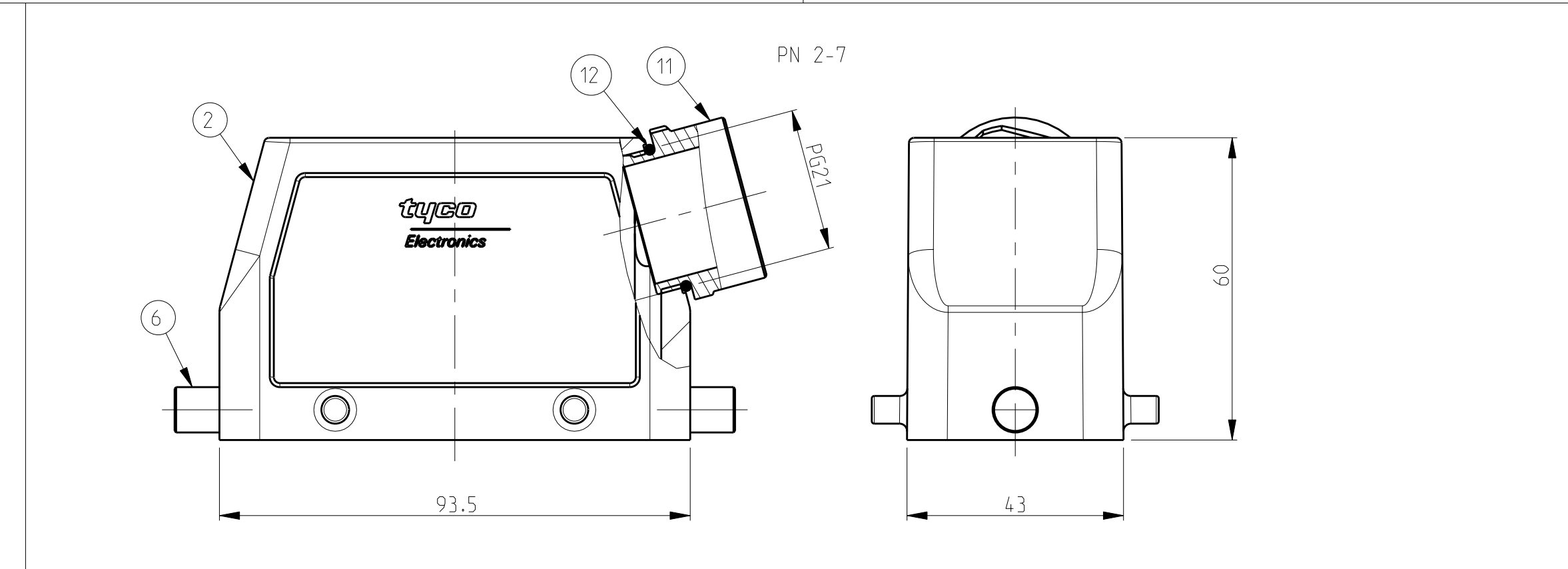
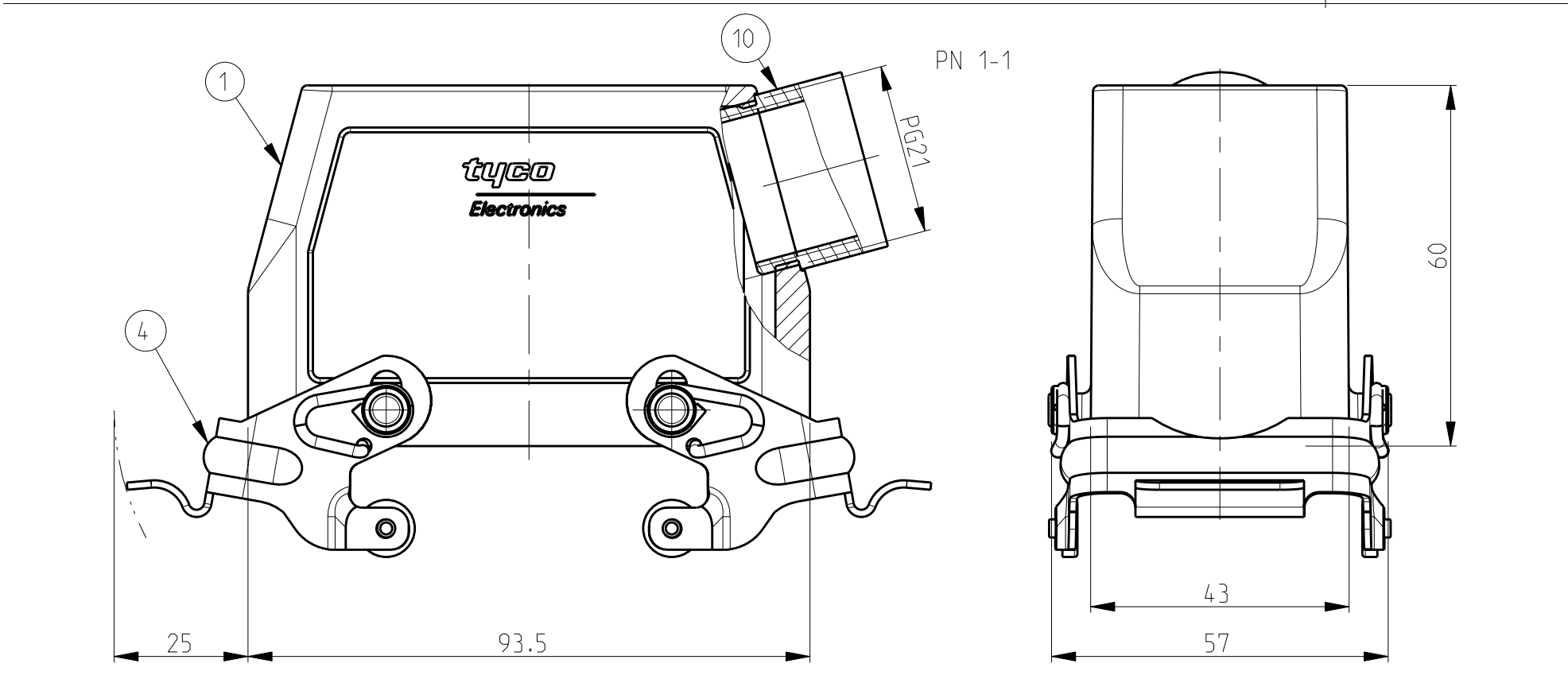
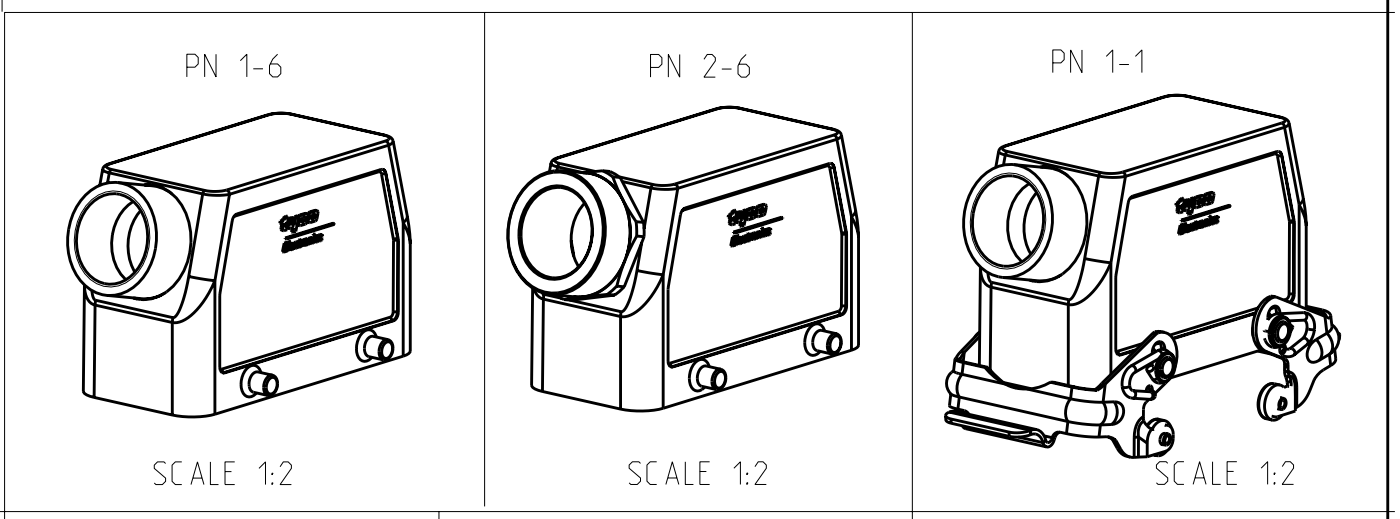
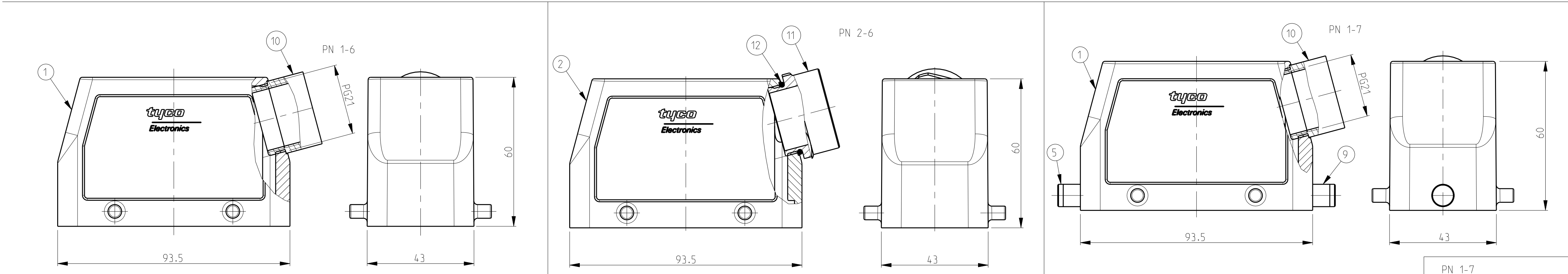

QTY	DESCRIPTION	MATERIAL	SURFACE	COLOR	ITEM NO	NOTES
1	O-Ring Pg21	Neoprene		Black	12	-
1	6-Kt Adapter PG21	Brass	Nickel plated		11	-
1	Adapter PG21	Brass	Nickel plated		10	-
2	Slide spool HB	Steel	Zinc plated	Blue	9	-
1	Clip fixing-ZB	Stainless steel			8	-
2	Clip fixing-ZB	Steel	Zinc plated	Blue	7	-
1	LB-Clip bolt	Stainless steel			6	-
2	LB-Clip bolt	Steel	Zinc plated	Blue	5	-
1	VS-Locking clip	Steel	Zinc plated	Blue	4	-
1	VS-Clip bolt	Stainless steel			3	-
1	Hood HB.16.Pg.1.21	Aluminium	Aluminium oxide	Black	2	-
1	Hood HB.16.Pg.1.21	Aluminium		Grey	1	-

TE Connectivity

NAME: Hood HB.16.1.21.Z

PRODUCT SPEC: 108-74.001, 108-74.003

APPLICATION SPEC: 114-74.001, 114-74.004

WEIGHT: A | 00779 C=1102290

CUSTOMER DRAW ING

SCALE: 1:1 SHEET: 1 OF 1 REV: A4