

CUSTOMER PRINT

PART NUMBER: CARA6C806PPXXX90

NOTES:

1. FINISHED PRODUCT TO BE COILED
2. OVERMOLD BOOT MATERIAL: UV PBT, BLACK
3. ELECTRICAL TEST: 100% CONTINUITY
4. ALL DIMENSIONS ARE REFERENCE EXCEPT THOSE WITH A TOLERANCE

ASS'Y P/N	"X" DIM
CARA6C806PP03990	3 FT. 3 1/2 IN. ±2 IN. [1M ±50.8mm]
CARA6C806PP07990	6 FT. 7 IN. ±2 IN. [2M ±50.8mm]
CARA6C806PP19790	16 FT. 5 IN. ±4 IN. [5M ±101.6mm]
CARA6C806PP39490	32 FT. 9 3/4 IN. ±8 IN. [10M ±203.2mm]
CARA6C806PPXXX90	

CABLE CUT LENGTH IN "INCHES"

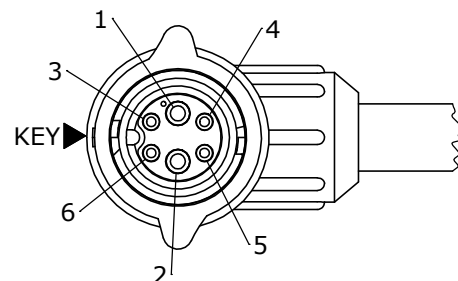
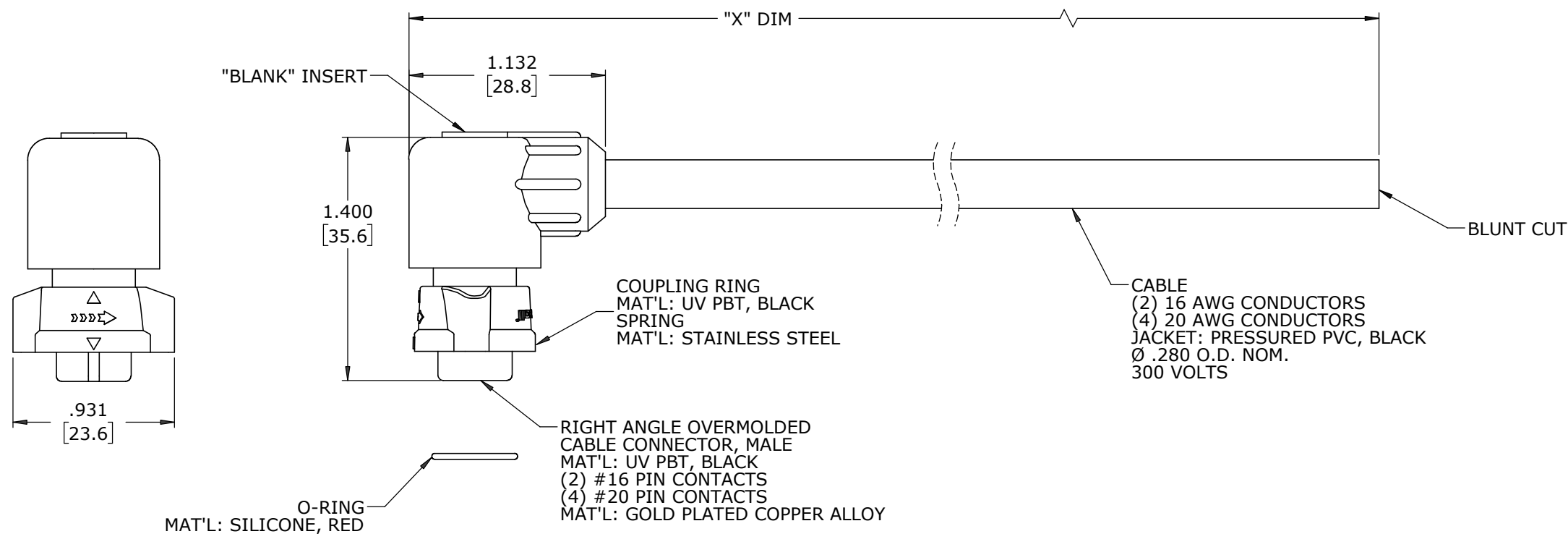

END "A"
FACE VIEW

DIMENSIONS IN BRACKETS [] ARE IN MILLIMETERS UNLESS INDICATED

WIRE COLOR CODE					
POS. 1	POS. 2	POS. 3	POS. 4	POS. 5	POS. 6
BLK	WHT	RED	BLU	GRN	YEL
16 AWG	16 AWG	20 AWG	20 AWG	20 AWG	20 AWG

CUSTOMER APPROVAL

THIS DOCUMENT CONTAINS CONFIDENTIAL INFORMATION PROPRIETARY TO CONXALL CORPORATION. ANY REPRODUCTION, DISCLOSURE, OR USE OF THIS DOCUMENT /INFORMATION IS EXPRESSLY PROHIBITED UNLESS AUTHORIZED IN WRITING BY CONXALL CORPORATION.

APPROVED BY: _____
DATE: _____

RoHS COMPLIANT

A	MA	08-18-21	DRAWING CREATED PER DOR 21-109361DS-1		
REV.	INIT.	DATE	DESCRIPTION		
	MA	08-18-21	ORIG. DRAWN BY: _____ DATE: 08-18-21 CHECKED BY: _____ APPROVED BY: _____ TITLE: CABLE ASSEMBLY, RA 2#16/4#20 PIN CONTACTS INSTA-CLICK™ MINI-CON-X MIX SIG BULLET CUSTOMER: STANDARD PRODUCT		
SCALE		SIZE	SHEET	PART NUMBER: CARA6C806PPXXX90	
NTS		B	1 OF 1	REV A	
FILE: CARA6C806PPXXX90		DIRECTORY: SLW			



ALL INFORMATION ILLUSTRATED IS THE PROPERTY OF "CONXALL CORPORATION". UNAUTHORIZED DUPLICATION OR DISTRIBUTION OF THIS DOCUMENT IS PROHIBITED.

ALL UNITS ARE IN FEET, INCHES, FRACTION OF INCHES AND DECIMALS.

— CRITICAL CHARACTERISTIC FLAG PER SPEC. XXXX