

## Automotive multifunction alternator voltage regulator for 12 V / 24 V on board networks

Datasheet - production data

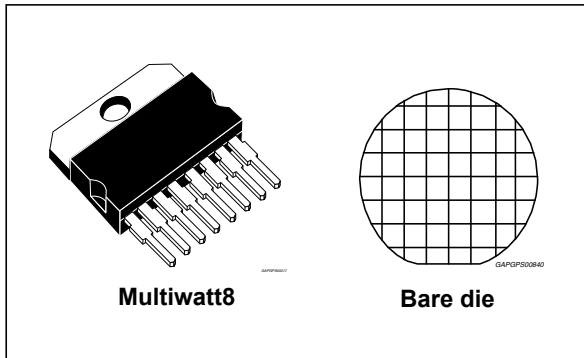

- Regulated voltage thermally compensated
- Configurable parameters through OTP cells
- Lamp driver (wake up and warning detection)
- Load response control (LRC)

### Protections

- Thermal shutdown
- Field short circuit protection
- Protected high side relay driver

### Features

- AEC-Q100 qualified
- Fully monolithic design
- High side field driver
- Self-start function



### Description

The L9916 is a smart alternator voltage regulator intended to be used in automotive application for both 12 V and 24 V systems. The presence of OTP cells for parameters programmability makes it suitable for a wide range of charging application.

**Table 1. Device summary**

Order code	Package	Packing
L9916	Multiwatt8	Tube
L9916BDTR	Bare die	Tape and Reel

# Contents

- 1 Functional description ..... 5**
  - 1.1 State diagram ..... 5
  - 1.2 Pin description ..... 7
  - 1.3 External component required ..... 7
  
- 2 Electrical specifications ..... 8**
  - 2.1 Absolute maximum ratings ..... 8
  - 2.2 Internal clamping structure ..... 8
  - 2.3 Thermal data ..... 9
  - 2.4 Electrical characteristics ..... 9
    - 2.4.1 Pin "B" ..... 9
    - 2.4.2 Pin "SENSE" ..... 15
    - 2.4.3 Pin "IGN" ..... 16
    - 2.4.4 Wake-up behaviour ..... 16
    - 2.4.5 Pin "FM" ..... 18
    - 2.4.6 Pin "PH" ..... 20
    - 2.4.7 Pin "F" ..... 23
    - 2.4.8 Pin "L" ..... 26
  - 2.5 Alarm detection ..... 29
  - 2.6 End of line test mode ..... 29
  - 2.7 OTP programming ..... 29
    - 2.7.1 External pull up resistor sizing ..... 30
  
- 3 Package information ..... 31**
  - 3.1 Multiwatt 8 (pin 5 GND) package information ..... 31
  - 3.2 Multiwatt 8 marking information ..... 33
  
- 4 Revision history ..... 34**

## List of tables

Table 1.	Device summary . . . . .	1
Table 2.	Pin out description . . . . .	7
Table 3.	Absolute maximum ratings . . . . .	8
Table 4.	Internal clamping structure . . . . .	8
Table 5.	Absolute maximum ratings and operative range. . . . .	8
Table 6.	Thermal data. . . . .	9
Table 7.	Electrical characteristics - Pin "B" . . . . .	9
Table 8.	VB over and under voltage parameters . . . . .	13
Table 9.	Electrical characteristics - Pin "SENSE" . . . . .	15
Table 10.	Electrical characteristics - Pin "IGN" . . . . .	16
Table 11.	Self-start function enabled . . . . .	17
Table 12.	Self-start function disabled . . . . .	17
Table 13.	Self-start function enabled (Mode 1). . . . .	17
Table 14.	Self-start function disabled (Mode 1) . . . . .	17
Table 15.	Self-start function enabled (Mode 2). . . . .	17
Table 16.	Electrical characteristics - Pin "FM" . . . . .	18
Table 17.	Electrical characteristics - Pin "PH" . . . . .	20
Table 18.	Electrical characteristics - Pin "F" . . . . .	23
Table 19.	Electrical characteristics - Pin "L" . . . . .	27
Table 20.	Alarm detection . . . . .	29
Table 21.	End of line test mode . . . . .	29
Table 22.	OTP programming electrical characteristics . . . . .	30
Table 23.	Multiwatt 8 (pin 5GND) package mechanical drawing . . . . .	32
Table 24.	Document revision history. . . . .	34

## List of figures

Figure 1.	Simplified application diagram	5
Figure 2.	State diagram	6
Figure 3.	Pin out diagram	7
Figure 4.	Regulated Voltage variation with the load	12
Figure 5.	Application 12 V - Default setpoint with $-3.5 \text{ mV}/^\circ\text{C}$	12
Figure 6.	Application 24 V - Default setpoint with $-3.5 \text{ mV}/^\circ\text{C}$	13
Figure 7.	VB over and under voltage	14
Figure 8.	Pin "IGN" diagrams	16
Figure 9.	Pin "FM" circuit and waveform	18
Figure 10.	Phase regulation in case VPH signal does not cross $V_{P_{prTh}}$	22
Figure 11.	Phase regulation in case VPH signal does not cross $V_{P_{LTh}}$	22
Figure 12.	Load response control function (LRC)	25
Figure 13.	Pin "L" circuit diagram	26
Figure 14.	Pin "L" waveform diagrams	27
Figure 15.	I <sup>2</sup> C interface circuit	30
Figure 16.	Multiwatt 8 (pin 5GND) package outline	31
Figure 17.	Multiwatt 8 marking information	33

# 1 Functional description

The L9916 is an alternator voltage regulator with high side power output for field driving. It can be used in both 12 V and 24 V system. It supplies a current through a power high side MOSFET to the excitation coil of the alternator and provides an internal freewheeling diode.

The L9916 is suitable for multi-phase-current alternators and its target function is to keep the battery at its nominal value, whatever the vehicle demand is. The set point control is achieved using an internal voltage reference thermally compensated. Continuous feedback to the ECU is provided through the field monitor output.

Slew rate control and filtering of the interface lines provide electromagnetic compatibility.

**Figure 1. Simplified application diagram**

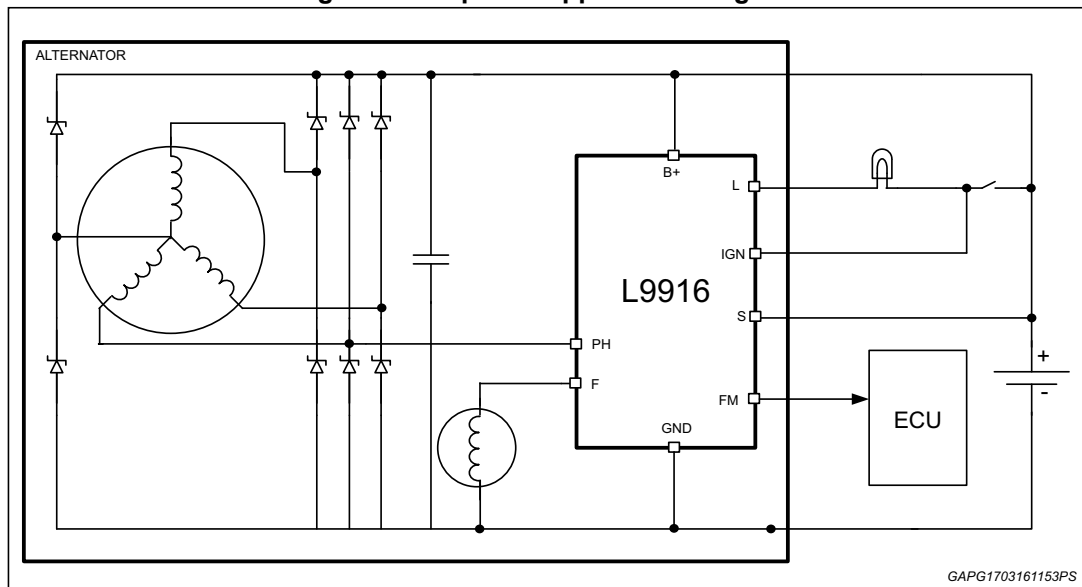

## 1.1 State diagram

The state diagram is a description of the L9916 possible working conditions.

Below it is represented a state diagram for L9916 describing its Operation Modes depending on the Speed Phase (RPM) applied to Phase pin (PH), the battery level on Battery pin (VB), the duty cycle applied by the device on Field pin (F), and the Alarm function status. Alarm function will turn-on the lamp in case of fault.

The states represented in the diagram are:

- Standby:  
It is the reference state of the FSM. It's the starting state and the final state for any regulator operation cycle (turn-on, turn-off).
- Pre-excitation:  
L9916 is ready to operate (when reached from standby), or it checks external conditions to move to a different state.

- Regulation:**  
 L9916 is working in order to regulate the battery voltage to the required voltage set point VBSP.
- Phase regulation:**  
 the L9916 controls the field driver to keep phase signal amplitude not falling below defined values.
- LRC:**  
 This state can be reached from Regulation in case there is a load variation that leads to meet some conditions on the expected field duty cycle value.
- Crank:**  
 This state is necessary to manage SDT (Start Delay Time) timer before entering normal regulation.

The assumptions considered in the below diagram are that the Self-start function is enabled and the wake-up source (IGN or Key) status is kept constant during the AVR working operation.

Colored tags define the condition for jumping to the next state and non-colored tags represent configurations.

Figure 2. State diagram

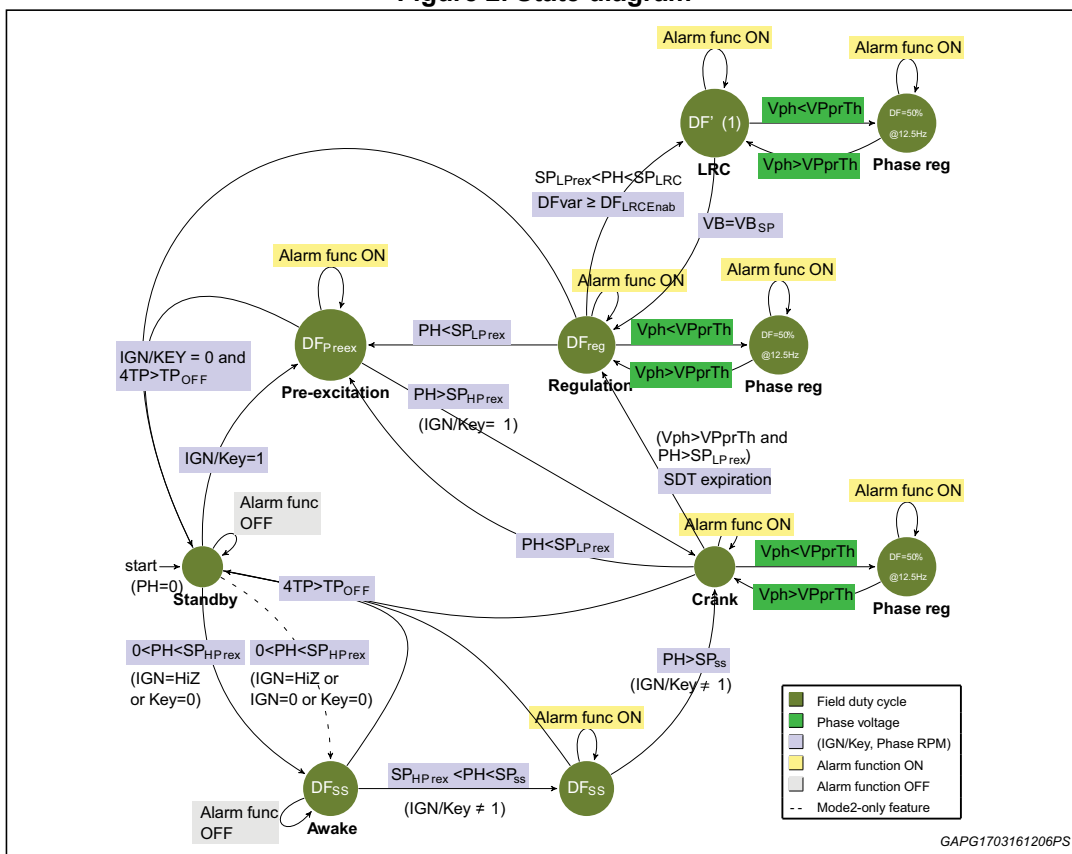

Note: LRC procedure firstly increases DF by DF<sub>LRCBZ</sub> and then it continues slowly increasing the DF using a fixed slope DF<sub>LRCUP</sub>. After LRC is finished (due to VB = VBSP condition reached), the new regulation duty cycle DF<sub>reg</sub> will be DF' reached by the LRC procedure.

## 1.2 Pin description

**Table 2. Pin out description**

N°	PIN	Function
1	PH	Phase sense input
2	FM	Field Monitor (PWM signal going to ECU)
3	IGN	Ignition input
4	LAMP	Key sensing and Warning Lamp terminal output
5	GND	Regulator ground
6	SENSE	Remote battery sense input
7	FIELD	High side driver output to control the Field current
8	B+	Device power supply and Battery voltage sensing

**Figure 3. Pin out diagram**

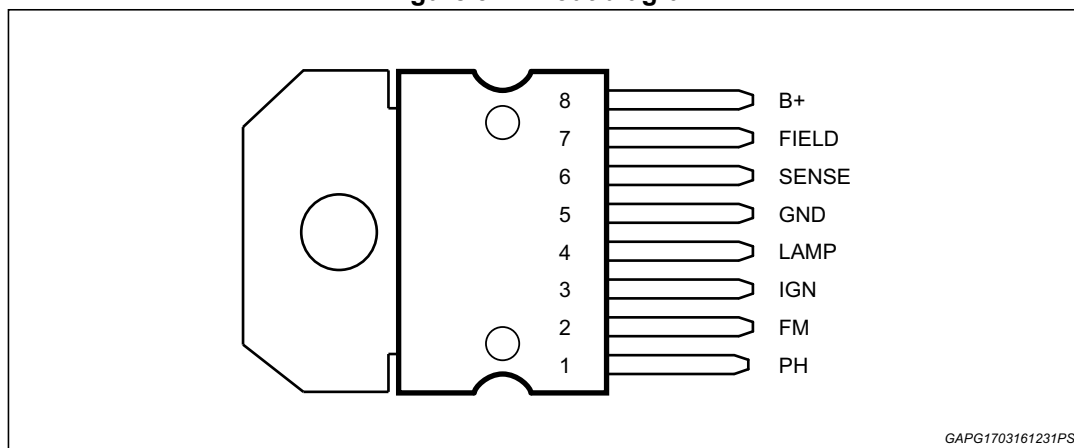

## 1.3 External component required

The only component strictly required is the capacitor C1 (2.2  $\mu$ F suggested) to suppress radio frequency injection and has to be connected as close as possible to B and GND pins.

If in the application some pins are not used, it is recommended to connect them to ground directly or with a 10 nF capacitor.

## 2 Electrical specifications

### 2.1 Absolute maximum ratings

Table 3. Absolute maximum ratings

Symbol	Parameter	Value	Unit
VB <sub>LD</sub>	Transient supply voltage (load dump) t < 500 ms	58	V
VB <sub>MAX</sub>	Transient supply voltage (low energy spikes) ISO7637-2 pulse 1,2,3 /ISO7637-3	58	V
T <sub>j</sub>	Junction temperature range	-40 to 175	°C
T <sub>stg</sub> , T <sub>case</sub>	Storage and case temperature range	-40 to 150	°C
P <sub>TOT</sub>	Total power dissipation (@ T <sub>case</sub> ≤ 150°C, I <sub>field</sub> ≤ 5 A)	4	W
VB <sub>R</sub>	Reverse battery voltage @ 25 °C, T = 15 sec	-2.5	V
VPH <sub>min</sub>	Normal working condition reverse voltage (PH vs. GND)	-1.5	V
I <sub>Bond</sub>	DC pin current on F, B, GND (bonding limitation)	15	A
ESD <sub>HBM</sub>	ESD HBM (All pins vs.GND)	±4	kV

### 2.2 Internal clamping structure

Table 4. Internal clamping structure

#	Symbol	Parameter	Test condition / Note	Min	Typ	Max	Unit
1	V <sub>cl</sub>	Internal central clamp voltage	B+ current injected I = 20 mA	58	-	64	V

Table 5. Absolute maximum ratings and operative range

Pin #	Pin name	ABS max rating		Operative range		Unit
		Min	Max	Min	Max	
1	PH	-25	Vcl	-3	36	V
2	FM	-25	Vcl	-0.3	36	V
3	IGN	-25	Vcl	-0.3	36	V
4	LAMP	-0.3	B+	-0.3	36	V
5	GND	-	-	-	-	-
6	SENSE	-25	Vcl	-0.3	36	V
7	FIELD	-1.5	B+	-1.5	B+	V
8	B+	-2.5	Vcl	6	36	V



## 2.3 Thermal data

Table 6. Thermal data

Symbol	Parameter	Test condition / Note	Min	Typ	Max	Unit
$R_{th\_j-case}$	Thermal resistance junction-to-case	Related to Multiwatt8	-	-	1.5	°C/W
$T_{j-sd}$	Thermal shutdown threshold	Temperature to disable F, FM, L drivers.	160	175	190	°C
$T_{j-sdhy}$	Thermal shut-down hysteresis	L, F, FM from OFF STATE (due to thermal shutdown) to ON STATE	$T_{j-sd}-10$	-	$T_{j-sd}-2$	°C
$T_j$	Operation temperature	-	-40	-	150	°C
		Fully functional. Parameter Deviations permissible	150	-	$T_{j-sd}$	

## 2.4 Electrical characteristics

$T_j = -40$  to  $150$  °C, unless otherwise specified.

### 2.4.1 Pin "B"

The L9916 is supplied by the B+. This voltage is also used as the feedback voltage by the regulation loop.

Table 7. Electrical characteristics - Pin "B"

#	Symbol	Parameter	Test condition / Note	Min	Typ	Max	Unit
1	$V_{B_{OVR}}$	Operating Voltage Range	Application info, refer to <a href="#">Figure 7</a>	6	-	36	V
2	$I_{B_{stby}}$	Standby current consumption 12 V	$V_B = 12.5$ V; $V_{PH} = 0$ ; $V_L = 0$ V; $VIGN = open$ ; $VSENSE = 0$ V $T = 25$ °C	-	-	120	μA
3	$I_{B_{stby}}$	Standby current consumption 12 V	$V_B = 12.5$ V; $V_{PH} = 0$ ; $V_L = 0$ V; $VIGN = open$ ; $VSENSE = 12.5$ V $T = 25$ °C	-	-	170	μA
4	$I_{B_{stby}}$	Standby current consumption 24 V	$V_B = 24$ V; $V_{PH} = 0$ ; $V_L = 0$ V; $VIGN = open$ ; $VSENSE = 0$ V $T = 25$ °C	-	-	160	μA
5	$I_{B_{stby}}$	Standby current consumption 24 V	$V_B = 24$ V; $V_{PH} = 0$ ; $V_L = 0$ V; $VIGN = open$ ; $VSENSE = 24$ V $T = 25$ °C	-	-	200	μA
6	$I_{B_{active}}$	Current consumption out of standby	$V_B = 12.5$ V; $VSENSE = 12.5$ V $V_B = 24$ V; $VSENSE = 24$ V No current load on FIELD and LAMP	5	11	30	mA

Table 7. Electrical characteristics - Pin "B" (continued)

#	Symbol	Parameter	Test condition / Note	Min	Typ	Max	Unit
7	VB <sub>SP12,1</sub>	Set-point voltage 12 V Option	VPH=10 Vpp square wave; L pin connected to B pin with 100 ohm; @ T <sub>j</sub> = 30 °C F duty cycle = 50%	-0.15	13.5	+0.15	V
8	VB <sub>SP12,2</sub>				13.6		
9	VB <sub>SP12,3</sub>				13.7		
10	VB <sub>SP12,4</sub>				13.8		
11	VB <sub>SP12,5</sub>				13.9		
12	VB <sub>SP12,6</sub>				14		
13	VB <sub>SP12,7</sub>				14.1		
14	VB <sub>SP12,8</sub>				14.2		
15	VB <sub>SP12,9</sub>				14.3		
16	VB <sub>SP12,10</sub>				14.4		
17	VB <sub>SP12,11</sub>				14.5		
18	VB <sub>SP12,12</sub>				14.6		
19	VB <sub>SP12,13</sub>				14.7		
20	VB <sub>SP12,14</sub>				14.8		
21	VB <sub>SP12,15</sub>	14.9					
22	VB <sub>SP12,16</sub>	15					
23	VB <sub>SP24,1</sub>	Set-point voltage 24 V Option	VPH=20 Vpp square wave; L pin connected to B pin with 100 ohm; @ T <sub>j</sub> =30°C F duty cycle=50%	-0.25	27	+0.25	V
24	VB <sub>SP24,2</sub>				27.2		
25	VB <sub>SP24,3</sub>				27.4		
26	VB <sub>SP24,4</sub>				27.6		
27	VB <sub>SP24,5</sub>				27.8		
28	VB <sub>SP24,6</sub>				28		
29	VB <sub>SP24,7</sub>				28.2		
30	VB <sub>SP24,8</sub>				28.4		
31	VB <sub>SP24,9</sub>				28.6		
32	VB <sub>SP24,10</sub>				28.8		
33	VB <sub>SP24,11</sub>				29		
34	VB <sub>SP24,12</sub>				29.2		
35	VB <sub>SP24,13</sub>				29.4		
36	VB <sub>SP24,14</sub>				29.6		
37	VB <sub>SP24,15</sub>				29.8		
38	VB <sub>SP24,16</sub>				30		

Table 7. Electrical characteristics - Pin "B" (continued)

#	Symbol	Parameter	Test condition / Note	Min	Typ	Max	Unit
39	VB <sub>ITD1</sub>	Internal Thermal Drift Options 30°C<T<150°C	-	-1(12 V) -2(24 V)	0	+1(12 V) +2(24 V)	mV/°C
40	VB <sub>ITD2</sub>		-		-2.5		
41	VB <sub>ITD3</sub>		-		-3.5		
42	VB <sub>ITD4</sub>		-		-7		
43	VB <sub>ITD5</sub>		-		-10		
39bis	VB <sub>ITD1</sub>	Internal Thermal Drift Options -40°C<T<30°C	-	-2(12 V) -4(24 V)	0	+2(12 V) +4(24 V)	mV/°C
40bis	VB <sub>ITD2</sub>		-		-2.5		
41bis	VB <sub>ITD3</sub>		-		-3.5		
42bis	VB <sub>ITD4</sub>		-		-7		
43bis	VB <sub>ITD5</sub>		-		-10		
44	ΔVB <sub>load,1</sub>	Regulated Voltage variation with the load 12 V (24 V) system	Difference between regulated voltage when F duty cycle is 10% and regulated voltage when F duty cycle is 90%	-	-	200 (300)	mV
45	ΔVB <sub>load,2</sub>	Regulated Voltage variation with the load 12 V (24 V) system	Difference between regulated voltage when F duty cycle is 10% and regulated voltage when F duty cycle is 90%	-	-	300 (400)	mV
46	ΔVB <sub>speed</sub> <sup>(1)</sup>	Regulated Voltage variation with the speed 12 V (24 V)	Difference between regulated voltage when I <sub>gen</sub> = 10 A 2000rpm<Alt speed<18000rpm	-	-	100 (150)	mV
47	VB <sub>wb12</sub> <sup>(1)</sup>	Regulation without battery 12 V system	I <sub>alt</sub> = 5 A resistive; T <sub>case</sub> = 25 °C; 2000 < rpm < 18000	12	-	16	V
48	VB <sub>wb24</sub> <sup>(1)</sup>	Regulation without battery 24 V system	I <sub>alt</sub> = 5 A resistive; T <sub>case</sub> = 25 °C; 2000 < rpm < 18000	22	-	34	V
49	VB <sub>SP_CL12</sub>	Set Point Voltage clamp at low temperature (-40°C) F duty cycle=50% 12 V system	-	14.7	15	15.3	V
50	VB <sub>SP_CL24</sub>	Set Point Voltage clamp at low temperature (-40°C) F duty cycle = 50% 24 V system	-	28.4	29	29.6	V

1. Alternator dependent parameter not tested.

Figure 4. Regulated Voltage variation with the load

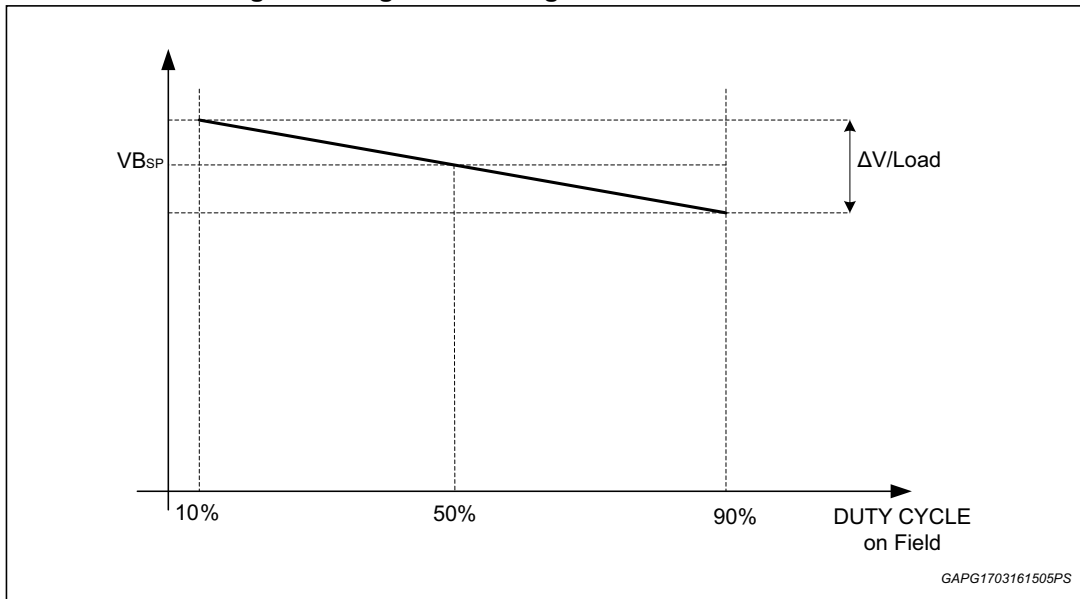
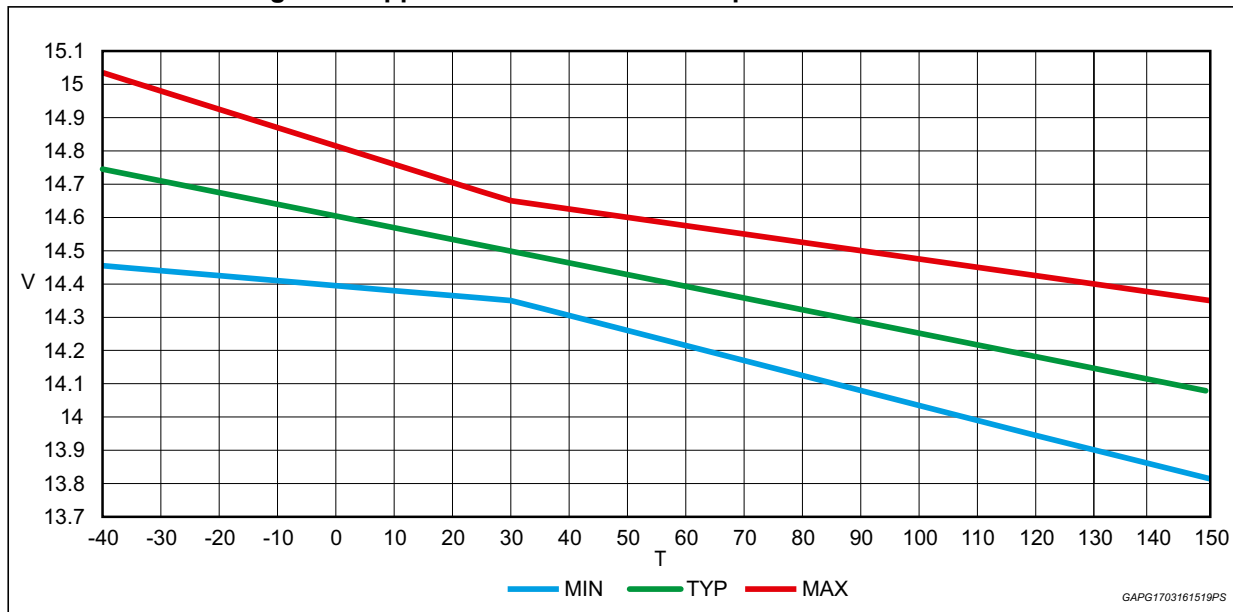
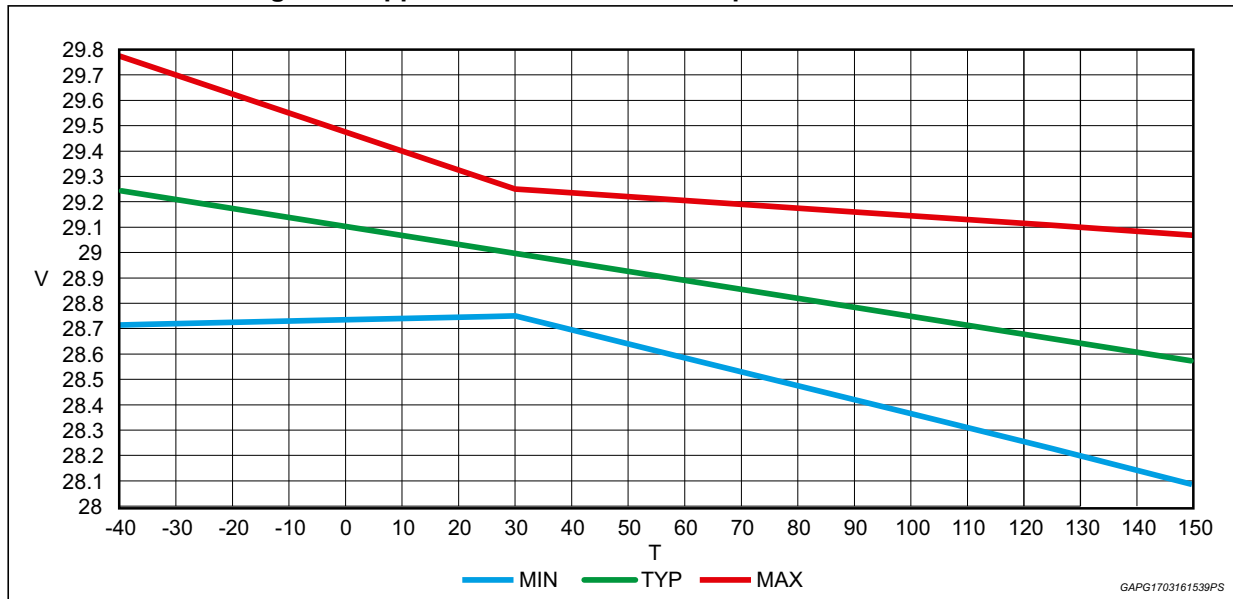

Figure 5. Application 12 V - Default setpoint with -3.5 mV/°C



Regulation Curves Versus Temperature @ F Duty Cycle = 50%  
 (Example with VBSP=14.5V, VBITD=-3.5mV/°C)

Figure 6. Application 24 V - Default setpoint with -3.5 mV/°C



Regulation Curves Versus Temperature @ F Duty Cycle = 50%

(Example with VBSP=29V, VBITD=-3.5mV/°C).

### Cranking security function

In order to avoid unpredictable regulation regions during the engine start, the regulator implements a Cranking Security Function.

At the ignition key on (i.e. "key" switch closed in the application schematic) the device starts in pre-excitation; in this phase the battery voltage is over both  $V_{B_{UV}}$  and  $V_{B_{LOW}}$  and the pin F provides a fixed duty cycle. When the starter is engaged, the battery sources a big current and then the applied voltage on the device decreases, as reported in ISO 7637-1 pulse 4 specification. If the voltage on pin B decreases under  $V_{B_{LOW}}$  threshold then the device will be frozen: the device will be in low current consumption with no activity on both F and FM pins.

The device will remain in frozen conditions until the voltage on B overcomes the  $V_{B_{low}}$  threshold. After that the device start again to evaluate the input coming from PH pin.

Table 8. VB over and under voltage parameters

#	Symbol	Parameter	Test condition / Note	Min	Typ	Max	Unit
1	$V_{B_{Ovp12V}}$	Over-voltage protections threshold 12 V system	-	16		16.9	V
2	$V_{B_{Ovp24V}}$	Over-voltage protections threshold 24 V system	-	32	33	34	V
3	$V_{B_{Ovft}}$	Over-voltage filter time	-	0.5	1.25	2	ms
4	$V_{B_{UV12V}}$	Under Voltage 12 V system	-	8	9	10	V
5	$V_{B_{UV24V}}$	Under Voltage 24 V system	-	16	18	20	V

**Table 8. VB over and under voltage parameters (continued)**

#	Symbol	Parameter	Test condition / Note	Min	Typ	Max	Unit
6	$V_{B_{low}}$	Low Voltage	-	5.6	6.35	7	V
7	$V_{BLV_{filt}}$	Low-voltage filter time	Guaranteed down to $V_{B_{low}}$	100	150	200	us

**Overvoltage**

For safety reason this function is implemented with independent circuitry with respect to the ones used by the field driver in order to guarantee that in case of overvoltage the field driver is securely switched off.

**Undervoltage**

When detected the L9916 switches on the lamp.

**Low voltage**

When detected the L9916 enters in stand by condition. All drivers are OFF including the lamp driver.

**Figure 7. VB over and under voltage**

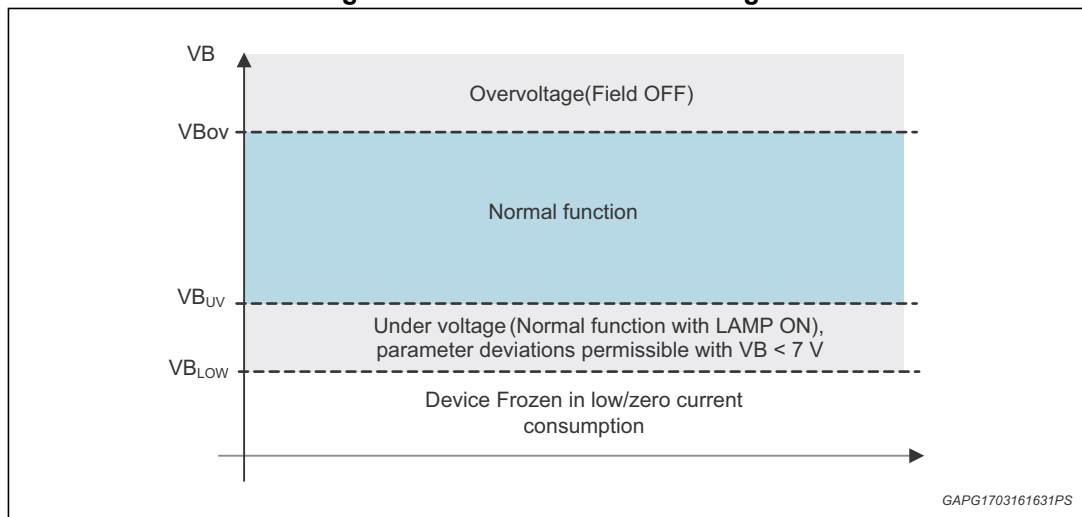

GAPG1703161631PS

## 2.4.2 Pin "SENSE"

The system battery can be directly sensed using the SENSE input. If the voltage on SENSE pin goes below the  $SENSE_{disc}$  threshold a sense disconnection is detected. If voltage of B+ is  $SENSE_{diff}$  greater than voltage of SENSE, the L9916 will use the B+ value to control the set point voltage, otherwise use SENSE voltage.

The device detects a 'sense loss' when either the sense disconnection or the voltage difference comparator is active.

It's possible to select if the voltage setpoint is increased by 1 V in case of sense loss.

**Table 9. Electrical characteristics - Pin "SENSE"**

#	Symbol	Parameter	Test condition / Note	Min	Typ	Max	Unit
1	$SENSE_{disc,12}$	Sense disconnected when Sense voltage is below	-	7.5	8.5	9.5	V
2	$SENSE_{disc,24}$		-	11	12	13	V
3	$SENSE_{diff,1}$	Voltage difference (B+) - Sense	-	1.2	1.6	2.1	V
4	$SENSE_{diff,2}$		-	1.8	2.3	2.9	V
5	Delta $V_{BSP}$	Voltage setpoint increase in case of SENSE loss	-	0.9	1	1.1	V
6	Filter time S to B+	Digital filter time to switch from S to B+ regulation	-	0.8	1	1.2	ms
7	Filter time B+ to S	Digital filter to switch from B+ to S regulation	-	160	200	240	ms
8	$I_{SENSE\_PD}$	Pull down current	-	10	45	80	$\mu A$

### 2.4.3 Pin "IGN"

The IGN pin is an input that can be used to wake-up the device in place of the Lamp and the selection is performed by OTP. The usage of one wake-up input (L or IGN) excludes the other one. The signal applied to IGN is compared to a threshold  $VIGN_{ON}$  and  $VIGN_{OFF}$  and the result is used to turn the device on. If not used this pin must be left open.

**Table 10. Electrical characteristics - Pin "IGN"**

#	Symbol	Parameter	Test condition / Note	Min	Typ	Max	Unit
1	$VIGN_{ON}$	Voltage threshold input comparator to switch on	-	6	8	10	V
2	$VIGN_{OFF}$	Voltage threshold input comparator to switch off	-	1.3	1.6	1.9	V
3	$VIGN_{OFFHYS}$	Voltage threshold input comparator to go in logic state = High Z	-	$VIGN_{OFF} + 0.25$	$VIGN_{OFF} + 0.35$	$VIGN_{OFF} + 0.45$	V
4	$R_{pu}$	Pull-up resistance	-	26	52	80	k $\Omega$

**Figure 8. Pin "IGN" diagrams**

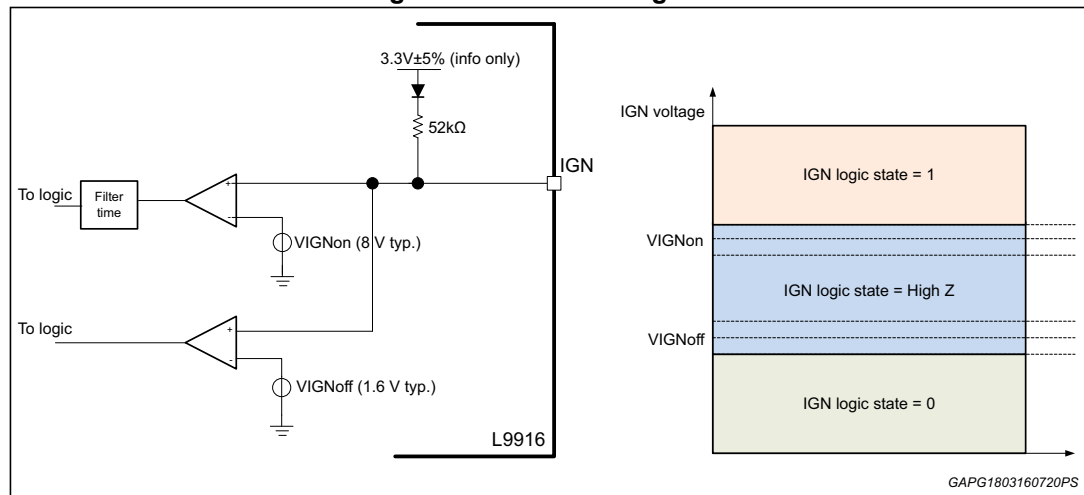

### 2.4.4 Wake-up behaviour

In this chapter it is described the device wake-up behaviour depending on the signal on IGN, L, PH pin and the selection between Mode1 and Mode2 done through OTP programming.

The device wakes-up through L pin or IGN pin.

*Note:* The IGN input pin is able to read 3 level voltages (see Figure 8), the below values for IGN are intended as follows:

- 1 = input voltage higher then  $VIGNIT_{ON}$
- 0 = input voltage lower then  $VIGNIT_{OFF}$
- High-Z = input voltage between  $VIGNIT_{OFF}$  and  $VIGNIT_{ON}$



IGN input not used (see [Section 2.4.3](#)).

**Table 11. Self-start function enabled**

IGN	L	PH	Regulator
X	0	Not present	OFF
X	0	Present	ON
X	1	Not present	ON
X	1	Present	ON

IGN input not used (see [Section 2.4.3](#)).

**Table 12. Self-start function disabled**

IGN	L	PH	Regulator
X	0	Not present	OFF
X	0	Present	OFF
X	1	Not present	ON
X	1	Present	ON

In case of condition L = 1, PH = present, regulator = ON the L signal becomes = 0, the regulator goes in OFF condition.

IGN input used (see [Section 2.4.3](#)).

**Table 13. Self-start function enabled (Mode 1)**

IGN	L	PH	Regulator
0	X	X	OFF
1	X	X	ON
High-Z	X	Not present	OFF
High-Z	X	Present	ON

IGN input used (see [Section 2.4.3](#)).

**Table 14. Self-start function disabled (Mode 1)**

IGN	L	PH	Regulator
0	X	X	OFF
1	X	X	ON
High-Z	X	Not present	OFF
High-Z	X	Present	OFF

IGN input used (see [Section 2.4.3](#)).

**Table 15. Self-start function enabled (Mode 2)**

IGN	L	PH	Regulator
0	X	Not present	OFF
0	X	Present	ON

Table 15. Self-start function enabled (Mode 2) (continued)

IGN	L	PH	Regulator
1	X	X	ON
High-Z	X	Not present	OFF
High-Z	X	Present	ON

Note: X = Don't care.

2.4.5 Pin "FM"

The pin Field Monitor is used to communicate to the ECU the information about the activity on the field.

Figure 9. Pin "FM" circuit and waveform

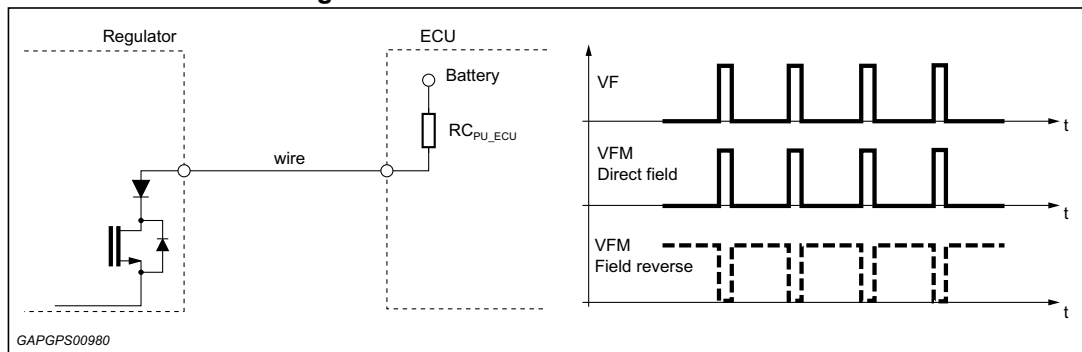

Table 16. Electrical characteristics - Pin "FM"

#	Symbol	Parameter	Test condition / Note	Min	Typ	Max	Unit
1	VM <sub>LVS</sub>	Low voltage saturation	I-sink = 14 mA	0.9	1.2	1.5	V
2	f <sub>M<sub>SW,1</sub></sub>	Field monitor frequency switch Option1	-	-	f <sub>FSW</sub>	-	Hz
	f <sub>M<sub>SW,2</sub></sub>	Field monitor frequency switch Option2	Not available if the Field switching freq = 125 Hz	-	f <sub>FSW</sub> /2	-	Hz
3	DM <sub>DCR</sub>	Field monitor duty cycle range	In case of duty cycle clamp selected	5	-	95	%
4	IM <sub>lim</sub>	Field monitor current limitation	-	25	50	75	mA
5	T <sub>lim</sub>	Duration of current limitation	-	50	-	100	µs
6	TF <sub>retry</sub>	Retry time in case of over-current		30	40	50	ms
7	I <sub>leak_FM</sub>	Leakage current	-	-	-	3	µA

The Field Monitor switching frequency can be selected to be the same as the field driver switching frequency or one half of it, using the OTP cells

The polarity of the Field Monitor signal can be selected "direct" or "reverse" respect to the field driver signal, using the OTP cells

The duty cycle of the Field Monitor signal can be selected to have maximum and minimum values of 95% and 5% in case the field signal has a duty cycle higher than 95% or lower than 5%, using the OTP cells.

In case of short to VB the current output is limited to  $IM_{lim}$  for a time equal to  $T_{lim}$  then the output is switched off and turned on again after  $TF_{retry}$

The duty cycle presented on FM is a replica, of a frequency depending on the OTP selection, of the duty cycle into the Field in order to provide to the ECU the information of the load connected to the alternator.

The duty cycle presented on FM is different from the signal on the Field in the following cases:

In the pre-excitation state FM always it has a fixed duty cycle equal to DFPreex (12.5%) whatever the battery voltage is.

When the device exits the pre-excitation, for all the time in which the phase regulation is active, on pin FM a signal with a duty cycle of 6% is presented. If the phase regulation persists over time the device continues to show a 6% duty cycle. Elapsed the phase regulation, the duty cycle of FM becomes equal to the duty cycle on the Field.

In the following requests of phase regulation, the Field executes the request while the FM continues to send the information of the entity of the current load. The activation of the field needed to implement the phase regulation is excluded from the account of the duty cycle: for example, if the battery voltage rises above the set point as a consequence of a load disconnection and a phase regulation is required, the field executes while FM continues to have a duty cycle of 0% (or its clamp value) that is the real load on the alternator in that moment.

**2.4.6 Pin "PH"**

The PH pin is the input for the phase signal coming from the alternator.

The  $VP_{HTH}$ ,  $VP_{LTh}$  are the voltage thresholds for the phase input detection used when the L pin or the IGN pin is connected. In case of self-start there are 4 couples of thresholds that can be selected and that are used for the first turn-on, once the speed exceeds the SPSS, x threshold the device will switch to the  $VP_{HTH}$ ,  $VP_{LTh}$  thresholds.

**Table 17. Electrical characteristics - Pin "PH"**

#	Symbol	Parameter	Test condition / Note	Min	Typ	Max	Unit
1	$VP_{HTH}$	High voltage threshold of hysteresis input buffer in case L or IGN connected and after self-start	-	1.3	1.45	1.6	V
2	$VP_{LTh}$	Low voltage threshold of hysteresis input buffer in case L or IGN connected and after self-start	-	0.85	1	1.15	V
3	$VP_{HTH\_SS1}$	High voltage threshold of hysteresis input buffer for self-start switch-on	-	0.25	0.37	0.45	V
4	$VP_{LTh\_SS1}$	Low voltage threshold of hysteresis input buffer for self-start switch-on	-	0.15	0.24	0.35	V
5	$VP_{HTH\_SS2}$	High voltage threshold of hysteresis input buffer for self-start switch-on	-	0.6	0.76	0.9	V
6	$VP_{LTh\_SS2}$	Low voltage threshold of hysteresis input buffer for self-start switch-on	-	0.35	0.45	0.6	V
7	$VP_{HTH\_SS3}$	High voltage threshold of hysteresis input buffer for self-start switch-on	-	1.1	1.22	1.35	V
8	$VP_{LTh\_SS3}$	Low voltage threshold of hysteresis input buffer for self-start switch-on	-	0.85	1	1.15	V
9	$VP_{HTH\_SS4}$	High voltage threshold of hysteresis input buffer for self-start switch-on	-	1.3	1.45	1.6	V
10	$VP_{LTh\_SS4}$	Low voltage threshold of hysteresis input buffer for self-start switch-on	-	0.85	1	1.15	V
11	$RP_{pd}$	Pull-down resistor (in addition to $IP_{pull-dw}$ )	-	7	15	22	kΩ
12	$TP_{SR}$	Spike rejection time	-	70	125	180	us
13	$IP_{pull-dw}$	Pull-down current (in addition to $RP_{pd}$ )	-	1.5	2	3.5	mA

Table 17. Electrical characteristics - Pin "PH" (continued)

#	Symbol	Parameter	Test condition / Note	Min	Typ	Max	Unit
14	SP <sub>HPrex,1</sub>	High rpm Threshold to exit pre-excitation Option1 <sup>(1)</sup>	-	Typ-10%	900	Typ+10%	rpm
15	SP <sub>HPrex,2</sub>	High rpm Threshold to exit pre-excitation Option2 <sup>(1)</sup>	-	Typ-10%	1200	Typ+10%	
16	SP <sub>HPrex,3</sub>	High rpm Threshold to exit pre-excitation Option3 <sup>(1)</sup>	-	Typ-10%	1500	Typ+10%	
17	SP <sub>HPrex,4</sub>	High rpm Threshold to exit pre-excitation Option4 <sup>(1)</sup>	-	Typ-10%	1800	Typ+10%	
18	SP <sub>HYS</sub>	Speed hysteresis	-	Typ-10%	200	Typ+10%	rpm
19	SP <sub>LPrex</sub>	Low speed threshold to enter pre excitation	-	SP <sub>HPrex</sub> - SP <sub>HYS</sub>			rpm
20	SP <sub>SS,1</sub>	Self-start rpm Threshold options <sup>(1)</sup>	-	Typ-10%	1200	Typ+10%	rpm
21	SP <sub>SS,2</sub>		-	Typ-10%	1500	Typ+10%	
22	SP <sub>SS,3</sub>		-	Typ-10%	2800	Typ+10%	
23	SP <sub>SS,4</sub>		-	Typ-10%	3200	Typ+10%	
24	SP <sub>LRC,1</sub>	rpm Threshold to exit/enter in LRC options	-	Typ-10%	1500	Typ+10%	rpm
25	SP <sub>LRC,2</sub>		-	Typ-10%	2800	Typ+10%	
26	SP <sub>LRC,3</sub>		-	Typ-10%	3000	Typ+10%	
27	SP <sub>LRC,4</sub>		-	Typ-10%	3200	Typ+10%	
28	VP <sub>prTh12V</sub>	High phase regulation voltage threshold 12 V <sub>app</sub>	-	6.7	7.7	8.7	V
29	VP <sub>prLTh12V</sub>	Low phase regulation voltage threshold 12 V <sub>app</sub>	-	3	4	5	V
30	VP <sub>prTh24V</sub>	High phase regulation voltage threshold 24 V <sub>app</sub>	-	14	15.5	17	V
31	VP <sub>prLTh24V</sub>	Low phase regulation voltage threshold 24 V <sub>app</sub>	-	5.2	6.2	7.2	V
32	TP <sub>OFF</sub>	Max windows time to detect 4 phase periods	-	57	64	71	ms

1. Recommended: SP<sub>SS</sub> ≥ SP<sub>HPrex</sub>.

To convert phase frequency (Hz) to rotation speed (rpm) according to alternator poles pair number (N), use the following equation:

$$\text{rotation speed (rpm)} = \text{phase frequency (Hz)} * 60 / N \text{ (rpm spread: } \pm 10\%)$$

### Principle of phase regulation

When VB is above the set-point voltage, the field driver is controlled to keep the phase peak voltage from falling below VP<sub>prTh</sub>. If the phase peak voltage drops below VP<sub>HTH</sub>, the phase regulation does not work. During the Phase regulation the field is driven with a fixed duty-cycle and frequency, T<sub>on</sub> = 40 ms and T<sub>off</sub> = 40 ms. If during the T<sub>on</sub> phase the VP<sub>prTh</sub> threshold is reached the field is switched off even if the 40 ms have not elapsed.

The phase regulation is performed in both cases, either the high level phase signal does not cross the  $VP_{prTh}$  threshold or the low level phase signal does not cross the  $VP_{LTh}$  threshold.

**Figure 10. Phase regulation in case VPH signal does not cross  $VP_{prTh}$**

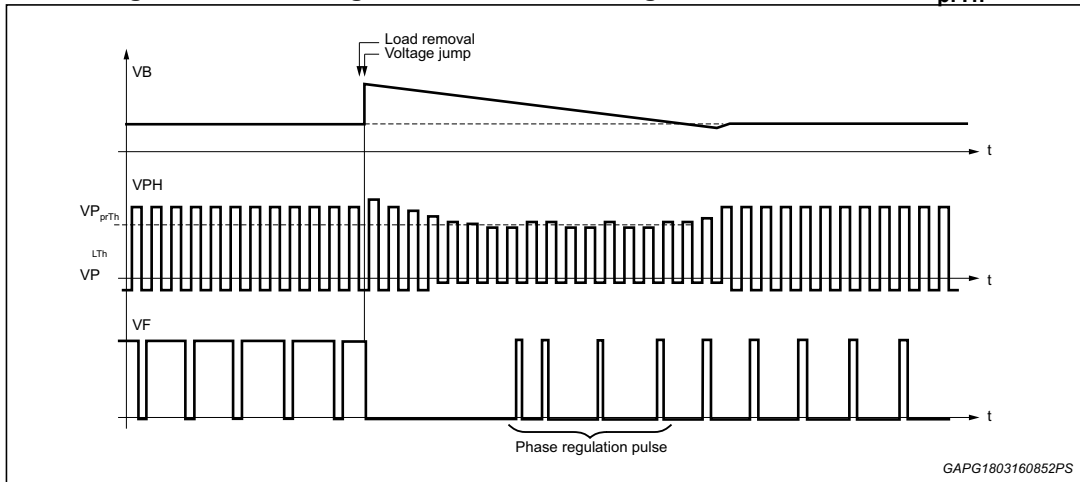

**Figure 11. Phase regulation in case VPH signal does not cross  $VP_{LTh}$**

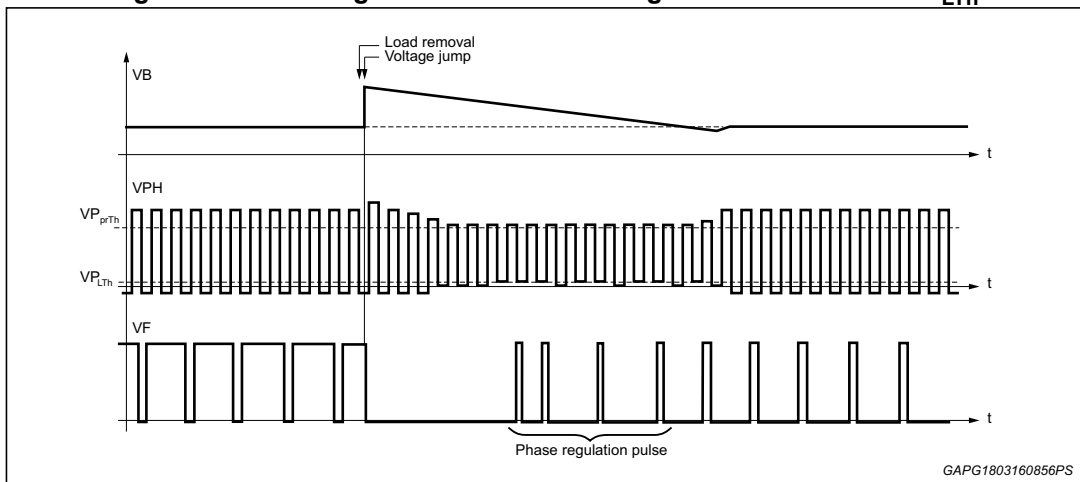

## 2.4.7 Pin "F"

The pin F is the output of the high side PowerMOS used to drive the field load.

**Table 18. Electrical characteristics - Pin "F"**

#	Symbol	Parameter	Test condition / Note	Min	Typ	Max	Unit
1	R <sub>on</sub>	R <sub>on</sub> field driver	T <sub>j</sub> = 130 °C; I <sub>sunk</sub> = 4.5 A			130	mΩ
2	V <sub>Fdiode</sub>	Freewheeling diode	I <sub>sourced</sub> = 5 A	-2			V
3	I <sub>Fleak</sub>	Field leakage current	V <sub>B</sub> = 50 V; V <sub>F</sub> = 0	-5		5	μA
4	I <sub>F<sub>OVP</sub></sub>	Field driver over-current protection	T <sub>j</sub> = -40 °C	9		18	A
			T <sub>j</sub> = 25 °C	8.5		18	A
			T <sub>j</sub> = 130 °C	8		18	A
5	I <sub>ocft</sub>	Over-current filter time	-	2.5	5	7.5	μs
5	T <sub>F<sub>retry</sub></sub>	Retry time in case of over-current		30	40	50	ms
6	V <sub>F<sub>ONdet</sub></sub>	Voltage threshold ON-state detection	-	0.9	1.1	1.3	V
7	f <sub>SW,1</sub>	Field switching frequency options	-	-10%	125	+10%	Hz
8	f <sub>SW,2</sub>		-	-10%	250	+10%	
9	f <sub>SW,3</sub>		-	-10%	333	+10%	
10	f <sub>SW,4</sub>		-	-10%	400	+10%	
11	T <sub>fall</sub>	Voltage slew rate for field driver (Measurement is performed between 80% and 20% of the slope)	V <sub>B</sub> = 14 V R = 270 Ω	1	4	10	μs
12	T <sub>rise</sub>	Voltage slew rate for field driver (Measurement is performed between 20% and 80% of the slope)	V <sub>B</sub> = 14 V R = 270 Ω	1	4	10	μs
13	DF <sub>Preex</sub>	Field duty cycle in pre-excitation	-	11	12.5	14	%
14	DF <sub>SS</sub>	Field duty cycle in self start	Applied when only "ph" signal is present and speed < SP <sub>SS</sub>	4	6	8	%

Table 18. Electrical characteristics - Pin "F" (continued)

#	Symbol	Parameter	Test condition / Note	Min	Typ	Max	Unit
15	TF <sub>LRCUP,1</sub>	Load Response Control Time (0% to 100% DC)	-	2.12	2.5	2.88	s
16	TF <sub>LRCUP,2</sub>		-	2.55	3	3.45	
17	TF <sub>LRCUP,3</sub>		-	4.25	5	5.75	
18	TF <sub>LRCUP,4</sub>		-	5.1	6	6.9	
19	TF <sub>LRCUP,5</sub>		-	6.37	7.5	8.63	
20	TF <sub>LRCUP,6</sub>		-	7.65	9	10.35	
21	TF <sub>LRCUP,7</sub>		-	8.5	10	11.5	
22	TF <sub>LRCUP,8</sub>		-	10.2	12	13.8	
23	DF <sub>LRCUP</sub>	Positive Duty Cycle vs. time variation	-	100 / TF <sub>LRCUP</sub>			%/s
24	TF <sub>LRCDW</sub>	Load Response Control Time (100% to 0% DC)	-	TF <sub>LRCUP</sub> * 3 / 8			s
25	DF <sub>LRCDW</sub>	Negative Duty Cycle vs. time variation	-	- 100 / TF <sub>LRCDW</sub>			%/s
26	DF <sub>LRCEnab</sub>	Current vs. Previous Duty Cycle Variation to Enable LRC Function (internal duty cycle sampled every 1ms)	-	4.1	6.7	9.2	%
27	DF <sub>LRCBZ</sub>	Blind Zone	<b>Test conditions:</b> Battery: VB = SetPoint - 0.3; SDT: Disabled Key/Ignition: Key-ON (VIGN ≥ VIGNON) Phase: VPH ≥ VPRHT  <b>Test:</b> RPM change from SPLPrex -100 to SPHPrex +100; F Duty-cycle has to change from 12.5% to 12.5%+BZ;	2.6	5.3	7.8	%
28	TF <sub>SDT,1</sub>	Start Delay Time options	-	0.4	0.5	0.6	s
	TF <sub>SDT,2</sub>		-	2.12	2.5	2.88	
	TF <sub>SDT,3</sub>		-	4.25	5	5.75	
	TF <sub>SDT,4</sub>		-	8.5	10	11.5	

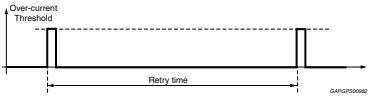

### Self-start function

In case no other wake up source is detected except the phase signal the device wakes up by self-start. During the self-start phase, the device will apply the  $DF_{SS}$  field duty cycle on the field if the speed is  $< SP_{SS}$ . Above  $SP_{SS}$  the device will work with the normal regulation.

### Load response control function (LRC)

Figure 12. Load response control function (LRC)

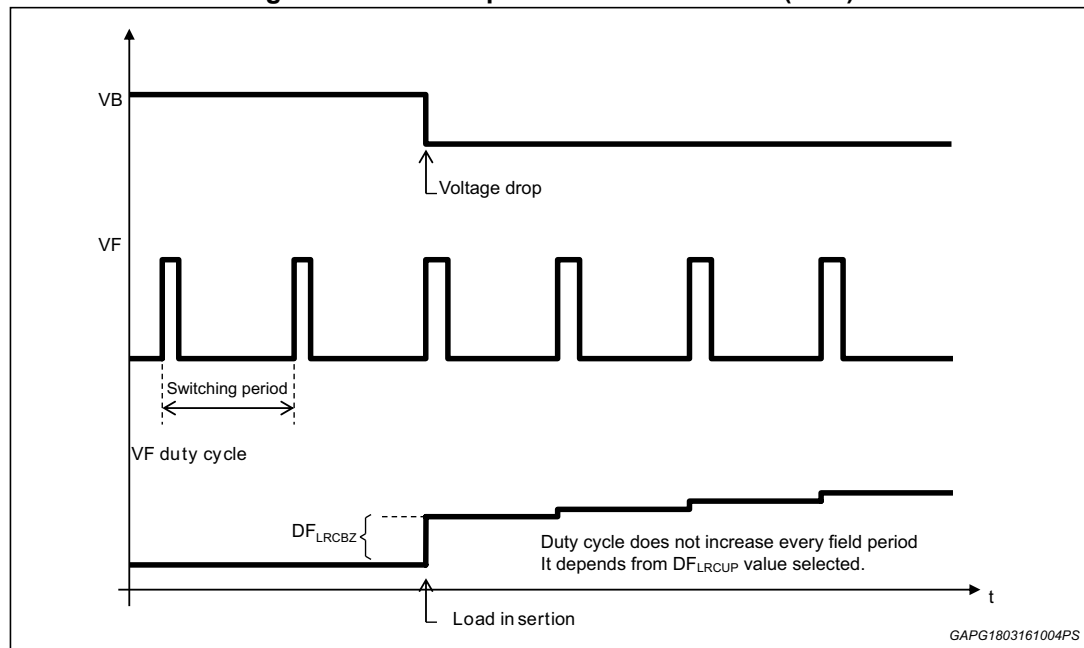

When an electrical load is applied in the system application, a drop in the regulated voltage (VB) occurs and the alternator reacts by increasing the output current. If the LRC function is active then the alternator output current is controlled by the Field current variation strategy, that is directly linked to the duty cycle on Field signal.

The LRC function can operate when the alternator runs at low speed (the PH signal frequency has to be lower than  $fP_{LRC}$ ) and it is activated when a positive variation between current duty cycle on Field and its previous duty cycle values is higher than the  $DF_{LRCEnab}$ . When the LRC function is required, the duty cycle increases slowly with the defined slope  $DF_{LRCUP}$  starting from the previous duty cycle increased by the fixed value  $DF_{LRCBZ}$ . The actual duty cycle management during a LRC insertion is shown in the [Figure 12](#). Once the LRC function is started it completes the required ramp even if the alternator speed becomes higher than the  $SP_{LRC}$ .

2.4.8 Pin "L"

The L pin is used to detect the key presence and to drive the warning lamp. It can also drive an optional relay for auxiliary loads.

Figure 13. Pin "L" circuit diagram

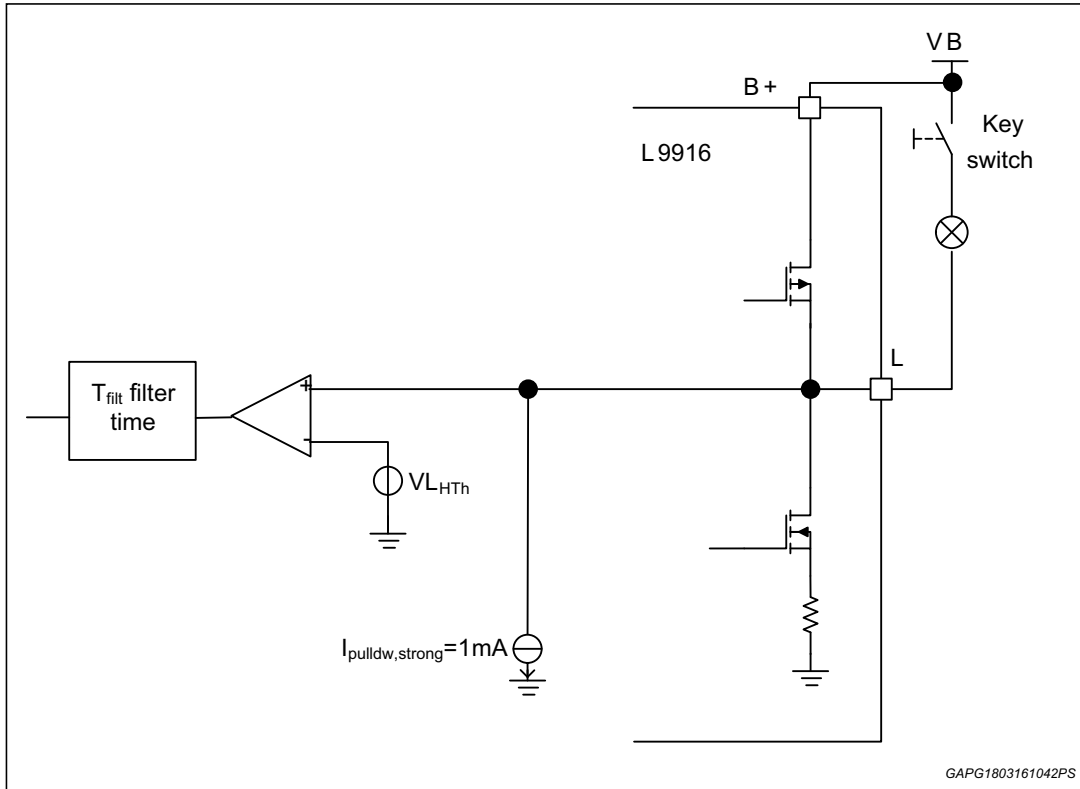

The L pin is used to drive the fault indicator lamp and the optional auxiliary load relay.

The device exits the stand-by mode when the switch "Key" is closed (i.e.  $V_L > V_{LHTH}$ ).

The Lamp is driven by an internal low side N-channel MOSFET whereas the relay is driven by an internal high-side N-channel MOSFET.

The current in Low side driver is limited to  $I_{LimLS}$  for a time  $T_{LOC}$ , then the driver is switched off. After  $T_{retry}$  the low side driver is turned on again.

To reduce the power dissipation in the lamp driver while it is ON, the following strategy is implemented: after key-on, as soon as the L pin voltage overcomes  $V_{Lth}$ , after  $T_{filter}$  time it is brought to  $V_{Lsat}$  voltage (between its drain and source), then the key status is verified every  $T_{wait}$  time intervals within a  $T_{chk}$  time window.

During this window, if the key is switched on the L voltage reaches the  $V_{LHTH}$  value and immediately returns to the  $V_{Lsat}$  value before the window expiration whereas, if the key is no longer active, the L voltage cannot increase and remains below key detection threshold ( $V_{LHT}$ ).

Figure 14. Pin "L" waveform diagrams

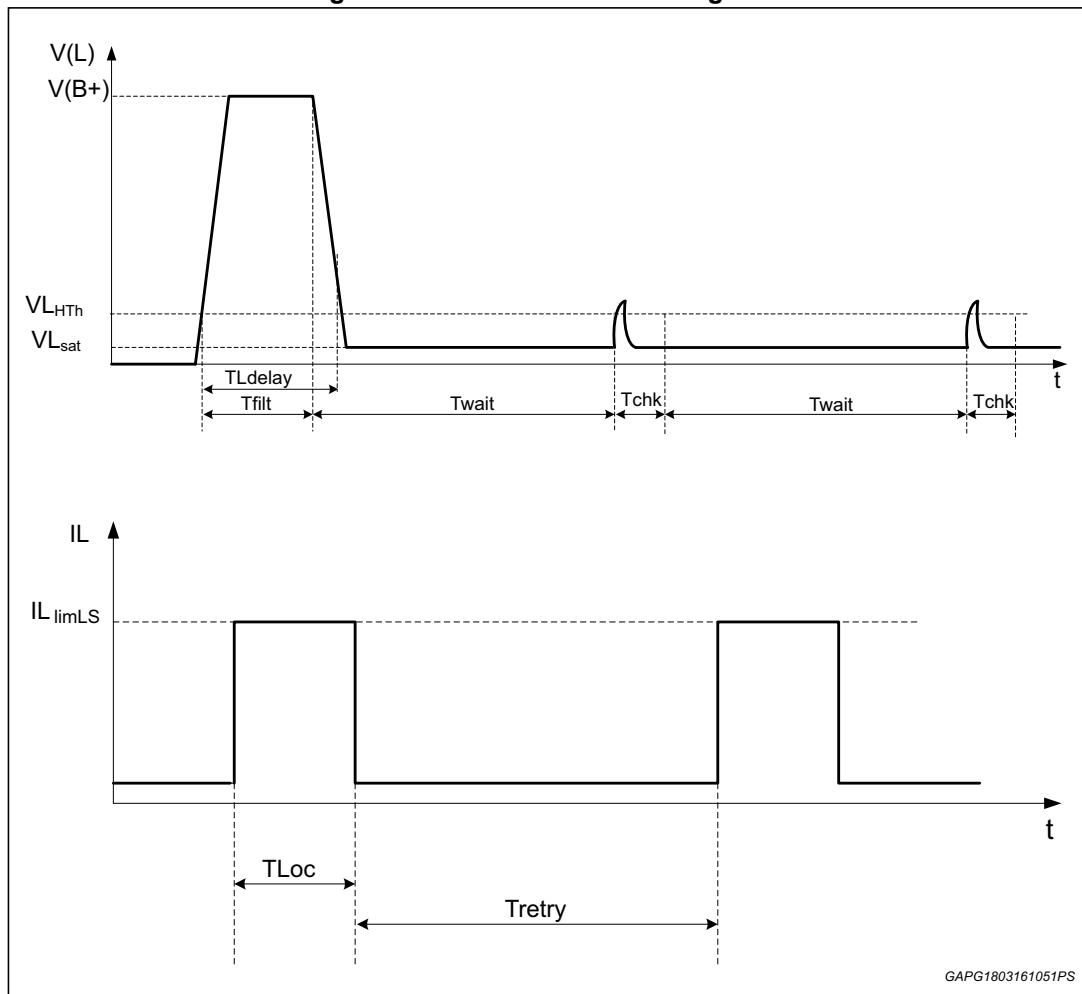

The high side driver is switched off if the current overcomes the  $IL_{OVCHS}$  for  $T_{LH}$  filter time.

Table 19. Electrical characteristics - Pin "L"

#	Symbol	Parameter	Test condition / Note	Min	Typ	Max	Unit
1	$V_{LSAT}$	Lamp Driver saturation Voltage	$I_{sunk} = 300 \text{ mA}$	-	-	0.3	V
2	$R_{onL}$	Ron Lamp driver	$T_j = 175 \text{ }^\circ\text{C}; I_{sunk} = 300 \text{ mA}$	-	-	1	$\Omega$
3	$I_{pulldw}$	Pull down current	-	0.6	1	1.4	mA
4	$T_{filt}$	Key-on filter time	-	-	40	-	$\mu\text{s}$
5	$T_{chk}$	Key presence check time window	Digital window time	-	-	1	ms

Table 19. Electrical characteristics - Pin "L" (continued)

#	Symbol	Parameter	Test condition / Note	Min	Typ	Max	Unit
6	T <sub>wait</sub>	Key presence interval	-	34	40	46	ms
7	V <sub>LHTh</sub>	High Voltage Threshold key-ON detector	-	0.8	0.9	1	V
8	I <sub>LlimLS,12V</sub>	LS current limitation threshold	-	1.2	-	2.4	A
9	I <sub>LlimLS,24V</sub>	LS current limitation threshold	-	0.6	-	1.2	A
10	T <sub>Ldelay</sub>	Turn ON delay time	-	-	-	100	us
11	T <sub>LOC</sub>	Maximum time duration of linear current limitation		-	30	35	ms
12	T <sub>Lretry</sub>	Retry time in case of over-current duration > T <sub>LOC</sub>		510	600	690	ms
13	V <sub>Hsat</sub>	Relay Driver saturation Voltage	V(B+)=12.6V; I <sub>sourced</sub> =0.3A	-	-	1	V
14	R <sub>onHS</sub>	Ron HS relay driver	T <sub>j</sub> =175°C; I <sub>source</sub> =300mA	-	-	3	Ω
15	I <sub>LOVCHS</sub>	HS Over-current threshold	-	1	-	2	A
16	T <sub>LHSretry</sub>	Retry time in case of over-current	-	30	40	50	ms
17	T <sub>LHfilter</sub>	HS Over current filter time	-	-	5	-	μs
18	T <sub>Lalarm,1</sub>	Alarm validation time	-	0.42	0.5	0.58	s
19	T <sub>Lalarm,2</sub>		-	0.85	1	1.15	
20	T <sub>Lalarm,3</sub>		-	1.27	1.5	1.73	
21	T <sub>Lalarm,4</sub>		-	1.7	2	2.3	

Note: In case Lamp Driver exceeds safety temperature, it will be turned OFF,

## 2.5 Alarm detection

The device turns ON the lamp after the validation time ( $TL_{alarm}$ ) if one of the conditions in the below table is verified.

**Table 20. Alarm detection**

Detection condition	Related pin/ Description	Configurable
$VPH < VP_{prTh}$ and $VB < VB_{SP}$	F driver or its connection degraded	No
$IF > IF_{OVP}$	F shortened to GND (Over-current on F driver)	No
$VB > VB_{SP}$ and $VF > VF_{ONdet}$	F shortened to B	No
$VB > VB_{Ovp12V}$   $VB > VB_{Ovp24V}$ <sup>(1)</sup>	Battery sensor on B pin or F driver degraded	No
$VB < VB_{UV}$	Low B Voltage (Battery under-voltage)	No
$VSENSE < SENSE_{disc}$	SENSE connection loss	Yes
$VIGNIT_{OFF} < VIGN < VIGNIT_{ON}$	VIGN open	Yes

1. In case of IGN interface enabled with self-start function enabled, if the IGN pin is in High\_z (Mode 1 and Mode 2) or at 0 level (only mode 2), the lamp and relay drivers are disabled if an overvoltage occurs.

In case of  $VPH < VPH_{Th}$  or PH frequency  $< f_{PLPrex}$  the device enters in pre-excitation state and turns ON the lamp.

Also during self start when  $SPH_{prex} < PH < SP_{ss}$  the device will enters in wakeup mode and turn on the lamp.

## 2.6 End of line test mode

Through the FM pin the device can enter a special "test mode" where some time consuming functions are not present.

The functions that are not present are:

LRC, SDT and  $TL_{alarm}$

To enter the "test mode" it is necessary to bring the FM pin voltage to  $V_{FM\_TM}$  and the device must not be in overvoltage condition ( $VB > VBO_{vp}$ ).

**Table 21. End of line test mode**

#	Symbol	Parameter	Test condition / Note	Min	Typ	Max	Unit
1	$V_{FM\_TM}$	Voltage threshold to enter in EOL test mode	-	37	41	45	V

## 2.7 OTP programming

The programming of the device parameters is achieved by using the I<sup>2</sup>C interface which is implemented on two pins (PH and DFM) having also such alternative functions.

Here below some general information on the I<sup>2</sup>C

The L9916 is I<sup>2</sup>C slave device, so SCL (clock line from I<sup>2</sup>C Master device) is input, while SDA (data line) is bidirectional to allow transmit/receive operations to/from I<sup>2</sup>C master device. Both SCL and SDA lines are connected to a positive power supply voltage via pull-up resistor. The I<sup>2</sup>C protocol defines the proper operations of the link. When the bus is free, both lines are High (pulled-up). The output stages of the devices connected to the bus must have an open-drain or open-collector to perform the wired-AND function. The maximum link rate is 400 kbit/s.

The required voltage for the OTP programming is 15.7 V±0.5 V.

For the programming procedure refer to the dedicated document.

Figure 15. I<sup>2</sup>C interface circuit

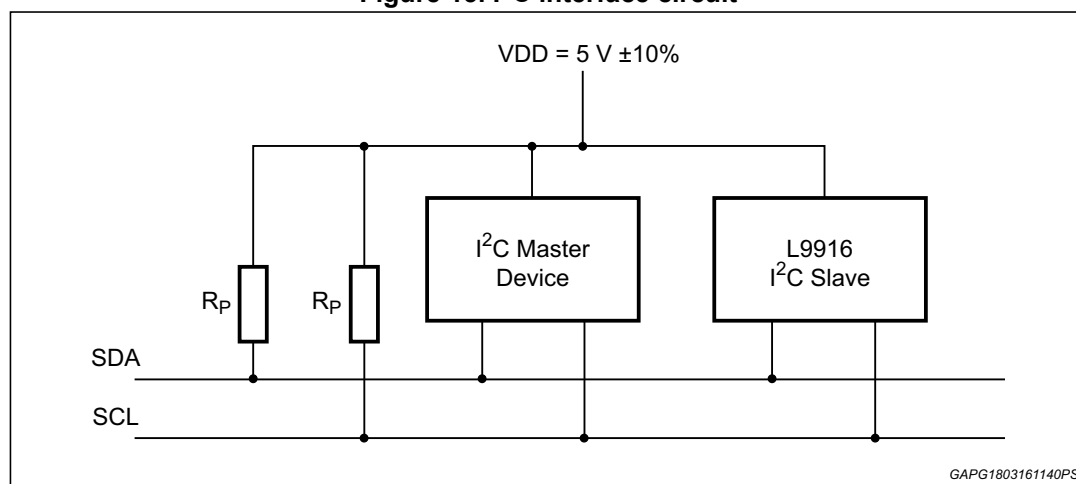

Table 22. OTP programming electrical characteristics

#	Symbol	Parameter	Test condition / Note	Min	Typ	Max	Unit
1	f <sub>SCL</sub>	Clock frequency	-	10		400	kHz
2	VIL	Input low voltage	-			1.5	V
3	VIH	Input high voltage	-	2.3			V

### 2.7.1 External pull up resistor sizing

Given:

C<sub>p</sub> = wiring (line) capacitance

f = Target frequency

R<sub>p</sub> = Pull up resistor

T = 1/f

τ = Time constant

and assuming that for proper operation τ < T/4, if the target frequency (SCL) is 100 kHz and the line capacitance is C<sub>p</sub> = 100 pF we got:

$$T = 1/f = 10 \mu s$$

$$\tau = R_p * C_p < T/4 = 2.5 \text{ ms} \Rightarrow R_p < 2.5 \text{ ms}/100 \text{ pF} = 25 \text{ k}\Omega$$

### 3 Package information

In order to meet environmental requirements, ST offers these devices in different grades of ECOPACK® packages, depending on their level of environmental compliance. ECOPACK® specifications, grade definitions and product status are available at: [www.st.com](http://www.st.com). ECOPACK® is an ST trademark.

#### 3.1 Multiwatt 8 (pin 5 GND) package information

Figure 16. Multiwatt 8 (pin 5GND) package outline

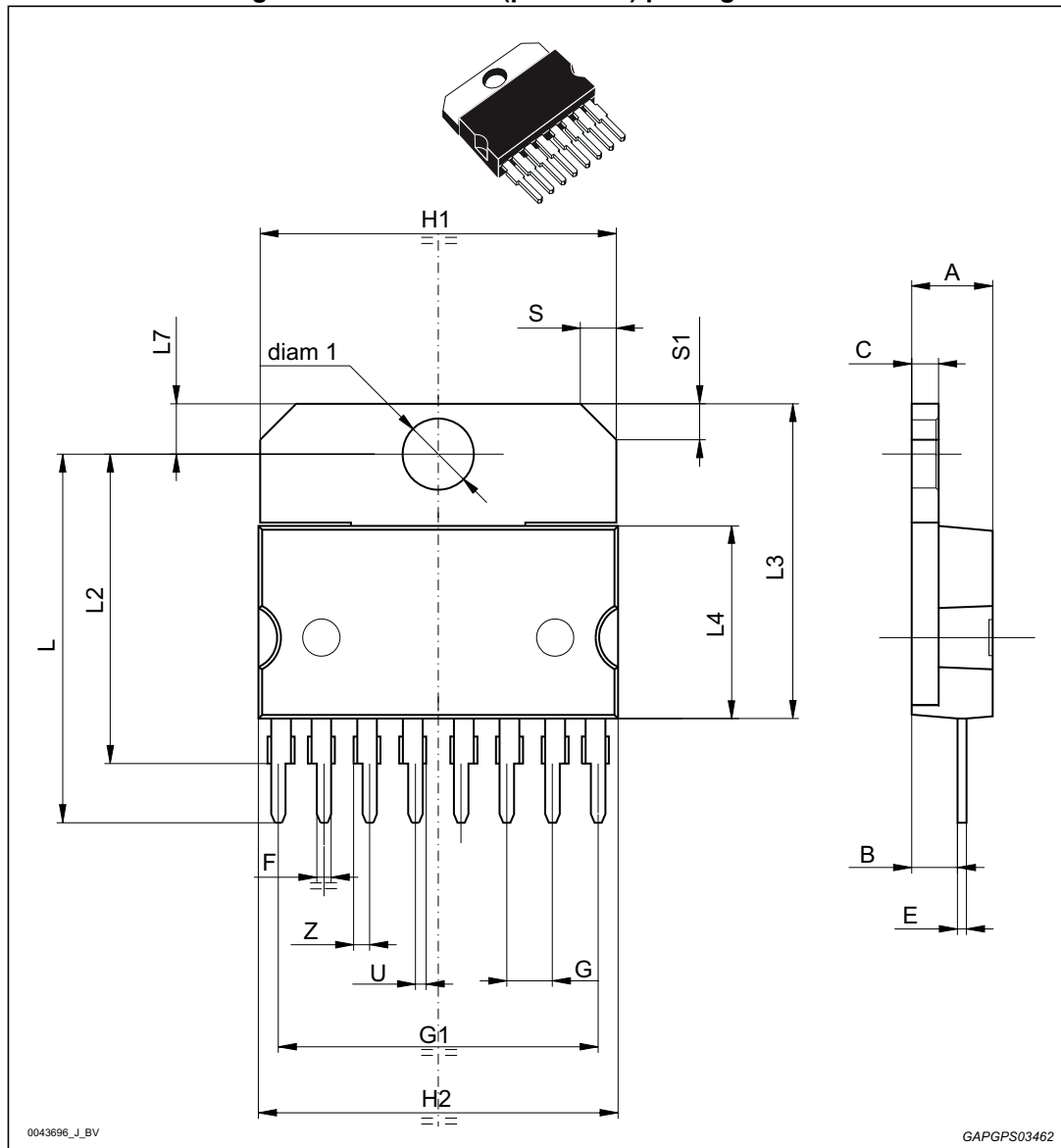

Table 23. Multiwatt 8 (pin 5GND) package mechanical drawing

Ref	Dimensions					
	Millimeters			Inches <sup>(1)</sup>		
	Min.	Typ.	Max.	Min.	Typ.	Max.
A	-	-	5	-	-	0.1969
B	-	-	2.65	-	-	0.1043
C	-	-	1.6	-	-	0.0630
E	0.49	-	0.55	0.0193	-	0.0217
F	0.78	-	0.85	0.0307	-	0.0335
G	2.40	2.54	2.68	0.0945	0.1000	0.1055
G1	17.64	17.78	17.92	0.6945	0.7000	0.7055
H1	19.6	-	-	0.7717	-	-
H2	-	-	20.2	-	-	0.7953
L	20.35		20.65	0.8012		0.8130
L2	17.05	17.20	17.35	0.6713	0.6772	0.6831
L3	17.25	17.5	17.75	0.6791	0.6890	0.6988
L4	10.3	10.7	10.9	0.4055	0.4213	0.4291
L7	2.65	-	2.9	0.1043	-	0.1142
S	1.9	-	2.6	0.0748	-	0.1024
S1	1.9	-	2.6	0.0748	-	0.1024
U	0.40	-	0.55	0.0157	-	0.0217
Z	0.70	-	0.85	0.0276	-	0.0335
diam1	3.65	-	3.85	0.1437	-	0.1516

1. Values in inches are converted from mm and rounded to 4 decimal digits.



### 3.2 Multiwatt 8 marking information

Figure 17. Multiwatt 8 marking information

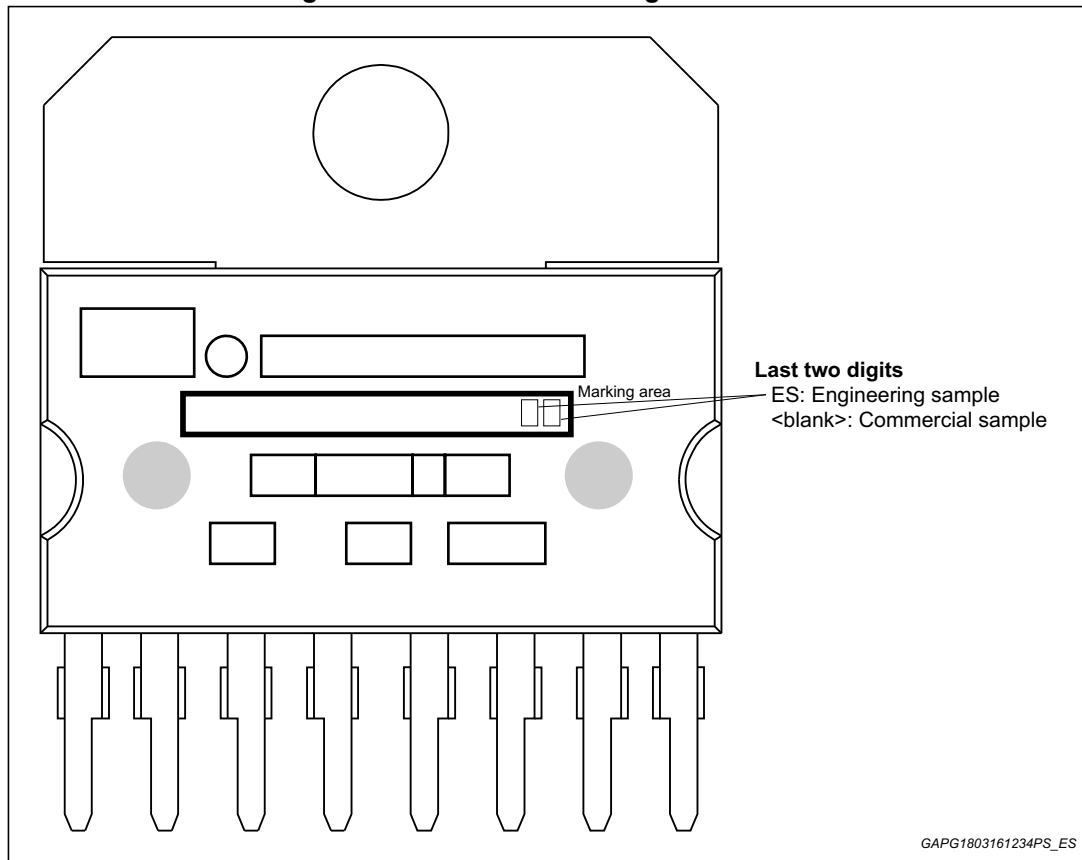

Parts marked as 'ES' are not yet qualified and therefore not approved for use in production. ST is not responsible for any consequences resulting from such use. In no event will ST be liable for the customer using any of these engineering samples in production. ST's Quality department must be contacted prior to any decision to use these engineering samples to run a qualification activity.

## 4 Revision history

**Table 24. Document revision history**

Date	Revision	Changes
20-Apr-2016	1	Initial release.
13-Jun-2016	2	<p>Modified on the <a href="#">Table 7: Electrical characteristics - Pin "B"</a> the test conditions for "<math>\Delta V_{B_{load,1}}</math> and <math>\Delta V_{B_{load,2}}</math>" parameter.</p> <p>Modified on the <a href="#">Table 8: VB over and under voltage parameters</a> the values for "<math>V_{B_{OVfit}}</math>" parameter.</p> <p>Updated:  <a href="#">Figure 2: State diagram on page 6</a>;  <a href="#">Figure 8: Pin "IGN" diagrams on page 16</a>.</p>
21-Aug-2017	3	<p><b>Updated:</b></p> <p>Sections:</p> <ul style="list-style-type: none"> <li>– <a href="#">Section 1.3: External component required on page 7</a>,</li> <li>– <a href="#">Section 2.1: Absolute maximum ratings on page 8</a>,</li> <li>– <a href="#">Section 2.4: Electrical characteristics on page 9</a>,</li> <li>– <a href="#">Section 2.5: Alarm detection on page 29</a>.</li> </ul> <p>Figures:</p> <ul style="list-style-type: none"> <li>– <a href="#">Figure 4: Regulated Voltage variation with the load on page 12</a>,</li> <li>– <a href="#">Figure 5: Application 12 V - Default setpoint with -3.5 mV/°C on page 12</a>,</li> <li>– <a href="#">Figure 6: Application 24 V - Default setpoint with -3.5 mV/°C on page 13</a>,</li> <li>– <a href="#">Figure 7: VB over and under voltage on page 14</a>,</li> <li>– <a href="#">Figure 8: Pin "IGN" diagrams on page 16</a>,</li> <li>– <a href="#">Figure 14: Pin "L" waveform diagrams on page 27</a>.</li> </ul> <p>Tables:</p> <ul style="list-style-type: none"> <li>– <a href="#">Table 1: Device summary on page 1</a></li> <li>– <a href="#">Table 3: Absolute maximum ratings on page 8</a>,</li> <li>– <a href="#">Table 6: Thermal data on page 9</a>;</li> <li>– <a href="#">Table 7: Electrical characteristics - Pin "B" on page 9</a>;</li> <li>– <a href="#">Table 8: VB over and under voltage parameters on page 13</a>,</li> <li>– <a href="#">Table 10: Electrical characteristics - Pin "IGN" on page 16</a>,</li> <li>– <a href="#">Table 17: Electrical characteristics - Pin "PH" on page 20</a>,</li> <li>– <a href="#">Table 18: Electrical characteristics - Pin "F" on page 23</a>,</li> <li>– <a href="#">Table 19: Electrical characteristics - Pin "L" on page 27</a>.</li> </ul>

**IMPORTANT NOTICE – PLEASE READ CAREFULLY**

STMicroelectronics NV and its subsidiaries (“ST”) reserve the right to make changes, corrections, enhancements, modifications, and improvements to ST products and/or to this document at any time without notice. Purchasers should obtain the latest relevant information on ST products before placing orders. ST products are sold pursuant to ST’s terms and conditions of sale in place at the time of order acknowledgement.

Purchasers are solely responsible for the choice, selection, and use of ST products and ST assumes no liability for application assistance or the design of Purchasers’ products.

No license, express or implied, to any intellectual property right is granted by ST herein.

Resale of ST products with provisions different from the information set forth herein shall void any warranty granted by ST for such product.

ST and the ST logo are trademarks of ST. All other product or service names are the property of their respective owners.

Information in this document supersedes and replaces information previously supplied in any prior versions of this document.

© 2017 STMicroelectronics – All rights reserved