

MATERIALS & SPECIFICATIONS

PART NO.	A 28500-015	REV	ECO	DATE	APP
		H	97733	06-27-11	TLM

HOUSING:
ALUMINUM 6061-T6, NICKEL
PLATE PER AMS-C-26074

INSULATOR:
LIQUID CRYSTAL POLYMER (LCP)
PER ASTM D5138

CONTACT:
BERYLLIUM COPPER PER ASTM
B194, C17200, GOLD PLATED
PER ASTM B488, (HARD GOLD)
TYPE II CODE C, CLASS 1.27

TERMINATION:
SOLDER COATED WITH SN63A PER
J-STD-006 OR AMS-P-81728

HARDWARE:
303 STAINLESS STEEL PER
ASTM 582

CURRENT RATING:
1 AMP MAX PER MIL-DTL-32139

CONTACT RESISTANCE:
71 MILLIOHM MAX (71mV DROP
MAX) @ 1.0 AMPS PER MIL-
DTL-32139

PERFORMANCE:
PRODUCT FAMILY TESTED TO AND
PASSED THE PERFORMANCE
SPECIFICATIONS OF TABLE VIII OF
MIL-DTL-32139

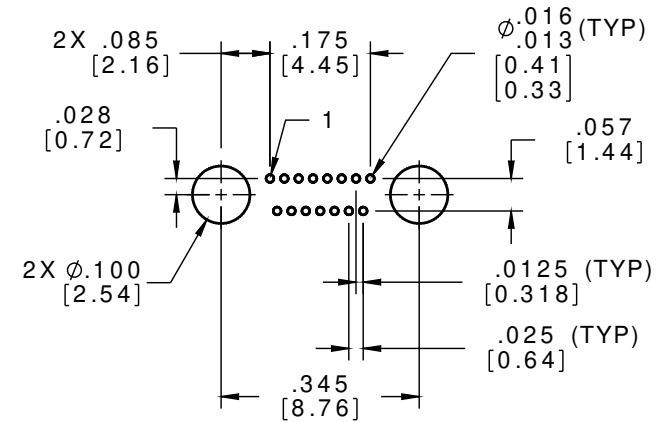
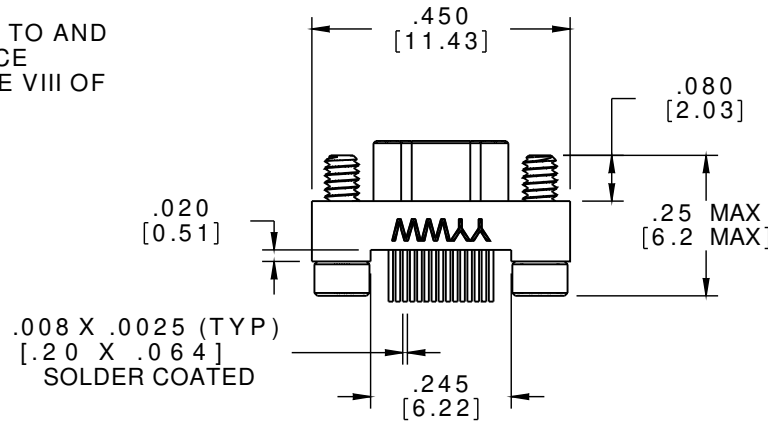
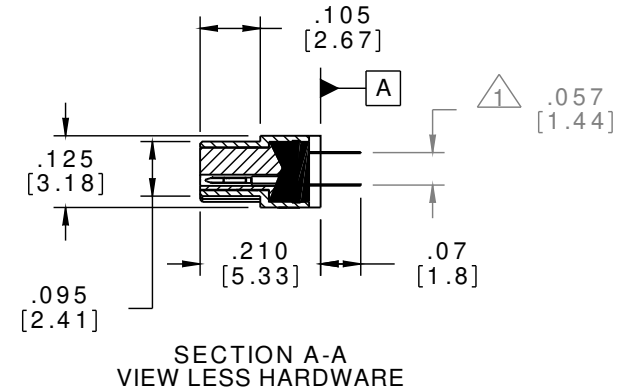
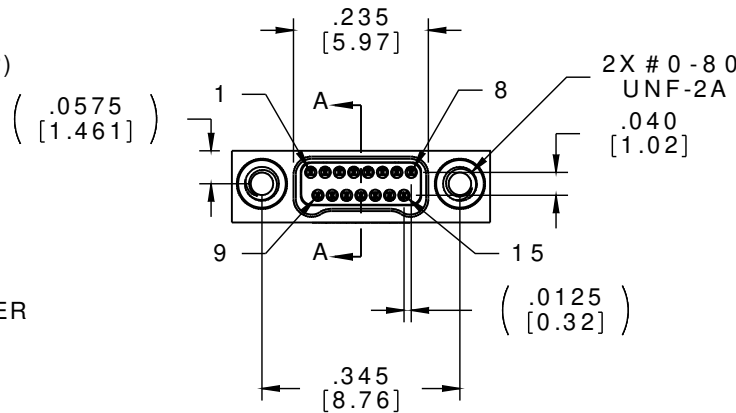

△ TAIL DIMENSIONS APPLY AT PLANE A



ACTUAL SIZE

MNP PO SLDW	THIRD ANGLE
	-TOLERANCES-
	UNLESS OTHERWISE NOTED
	DIMENSIONS IN INCHES
2 PL DEC ± .01	
3 PL DEC ± .005	
4 PL DEC ± .0005	
ANGLES ± 1°	

THIS DRAWING CONTAINS CONFIDENTIAL AND PROPRIETARY INFORMATION WHICH IS THE PROPERTY OF OMNETICS CONNECTOR CORP. THIS DOCUMENT MAY NOT, IN WHOLE OR IN PART, BE DUPLICATED, OR DISCLOSED FOR ANY PURPOSE, WITHOUT WRITTEN PERMISSION FROM OMNETICS CONNECTOR CORP.	
DFTM. AAS	DATE 05-05-04
CHK'D.	DATE
APP'D.	DATE
TITLE: (15) PIN MALE Bi-Lobe® CONNECTOR	

OMNETICS
CONNECTOR CORPORATION
7260 COMMERCE CIRCLE EAST
MINNEAPOLIS, MN 55432
WWW.OMNETICS.COM

CAGE CODE 61873
DWG NO. A28500-015
SHEET 1 OF 1
SCALE: 3:1
REV H