

ISL6298EVAL1

Evaluation Board

AN1171
Rev.0.00
February 9, 2005

Description

The ISL6298EVAL1 provides a complete platform for the evaluation of the ISL6298-2CR3. The on-board 9-bit DIP switch facilitates programming charging current, setting EN input, temperature monitoring status, and so on. The four jumpers can set up input source selection, USB mode selection, and can be used to make other necessary connections.

Assembled in the center square, the components constitute a complete charger solution, demonstrating the space saving advantage of the ISL6298 in limited space applications.

LEDs connected to FAULT and STATUS pins will indicate the normal charging status or fault condition.

On-board jumpers and a DIP switch accommodate different operation conditions for the charger.

Ordering Information

PART NUMBER	DESCRIPTION
ISL6298EVAL1	Evaluation Board for ISL6298-2CR3

Features

- 9-bit DIP switch for conveniently setting up charging current, battery thermal status, EN input, and so on
- Different jumpers for input source selection, USB mode selection, and the convenience of current measurement
- Exposed soldering pads connected to STATUS, FAULT, TIME, EN, V2P8 and TEMP functional pins to accommodate experimental testing that need extra connections to those pins
- Board size 3.5 x 2.5 square inches for the convenience of evaluation
- Eight thermal vias in the thermal pad simulating the customers' thermally enhanced environment

Pinout

ISL6298 3X3 DFN
TOP VIEW

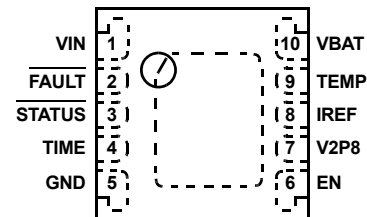

What is inside

The Evaluation Kit contains:

- ISL6298EVAL1 board
- The ISL6298 Data Sheet
- This ISL6298EVAL1 Application Note

What is needed

The following instruments will be needed to perform testing:

- Power supplies:
 - 1.PS1: DC 20V/5A,
 - 2.PS2: DC (sinks current) 20V/5A, such as Agilent 6654A
- Electronic load: 20V/5A
- Multimeters
- Function generator
- Oscilloscope
- Cables and wires

Quick Setup Guide

Step 1: Switch on bit 4 and bit 7 of the Dip-switch. Leave all other bits off, (See Figure 1.)

DO NOT APPLY POWER UNTIL STEP 6

- Step 1: Connect 5V on VIN.*
- Step 2: Connect 3.7V on VBAT.*
- Step 3: Connect 500mA electronic load on VBAT.*
- Step 4: Verify that no shunts across all jumpers.*
- Step 5: Turn on Power Supplies and electronic load.*
- Step 6: Green LED should be on, indicating normal charging operation.*
- Step 7: If current meter is in series with VIN, it shall read 250mA as the charging current.*

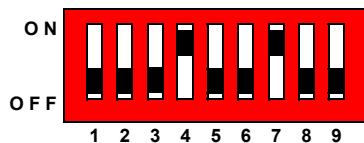

FIGURE 1. INITIAL DIP SWITCH SETTINGS

DIP Switch Settings

A 9-bit DIP switch is provided to set up voltage, current reference, end-of-charge (EOC) current, and so on. The functionality of the bits are described in Table 1.

TABLE 1. DIP SWITCH PIN DESCRIPTIONS

Bit	Description	ON	OFF	Remark
1	Adjustable TIMEOUT	5 hours 50 mins	3 hours 30 mins	
2				not connected
3	Charger enable/disable	charger disabled	charger enabled	
4	IREF setting 1	Add 125mA	I _{CHG} =125mA When both off	
5	IREF setting 2	Add 250mA		
6				not connected
7	TEMP normal	normal		All off simulates battery removal
8	TEMP high	too hot		
9	TEMP low	too cold		

TABLE 2. JUMPER SETTINGS

JUMPER	POSITION	FUNCTION
JP1	USB TO VIN	USB connection
	WALL CUBE TO VIN	Wall adapter connection
JP2	Installed	connect VBAT pin to battery current meter can replace shunt
JP3	not installed	default
	installed	Battery attached to Thermistor at J2
JP4	IREF and V2P8	USB 255mA
	IREF and GND	USB 100mA

Initial Board Jumper Positioning (Refer to Figure 3)

JP1 - Selects the VIN pin to be connected to either wall adapter, or to USB connector. If J1 connector is being used, a shunt must be installed across 'WALL CUBE TO VIN', or if J3 (USB) connector is being used a shunt must be installed across 'USB TO VIN'. J1, J3 and JP1 can be ignored if power supply is connected directly to VIN test point, which is directly connected to VIN pin of the IC. A current meter can replace the shunt mentioned above, so as to measure the input current.

JP2 - Can connect the VBAT pin to the battery. If the J2 connector is being used, a shunt must be installed across JP2. In this case, a current meter can also replace the shunt to measure the VBAT current.

JP3 - Can connect the TEMP pin to the battery. Usually no shunt is needed for JP3, as the Eval board can simulate various battery thermal conditions. Only when a battery attached with a thermistor is applied on J2 does it become necessary to install a shunt across JP3, and at the same time bit 7, 8, 9 on the DIP switch all need to be turned off.

JP4 - Selects USB modes: a shunt across IREF and V2P8 will set USB 250mA mode, a shunt across IREF and GND will set USB 100mA mode. When the charge current is programmed by the resistors connected to IREF pin, no shunt should be installed on JP4.

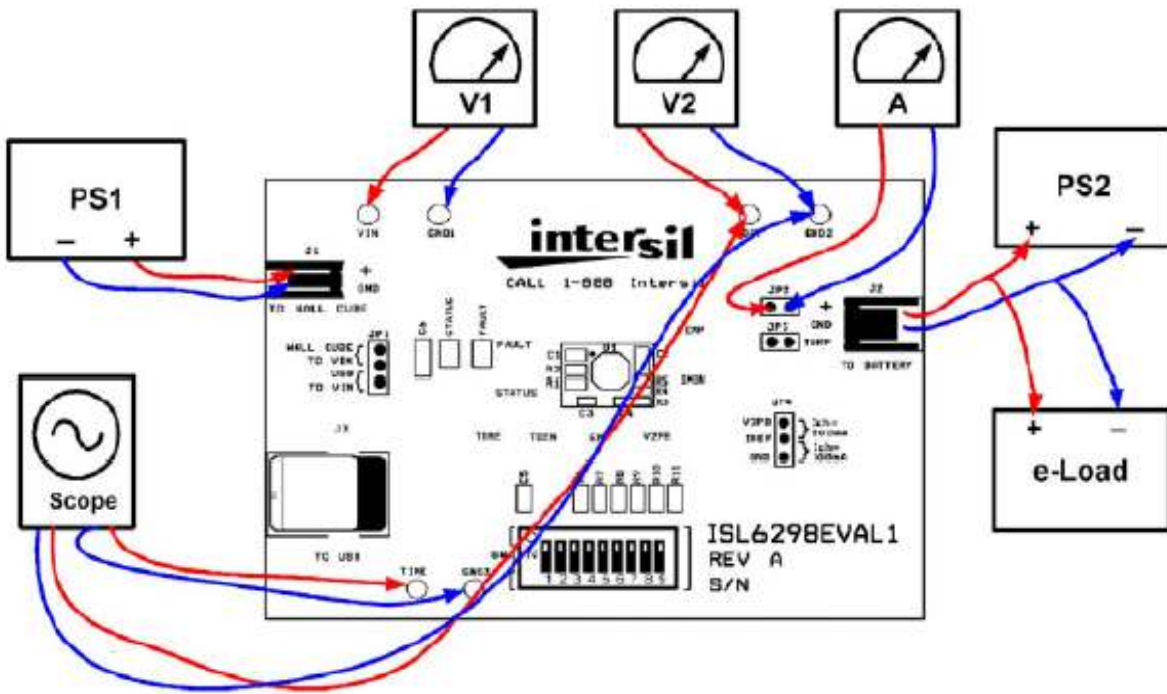

FIGURE 2. CONNECTION OF INSTRUMENTS

Board Information
Schematics

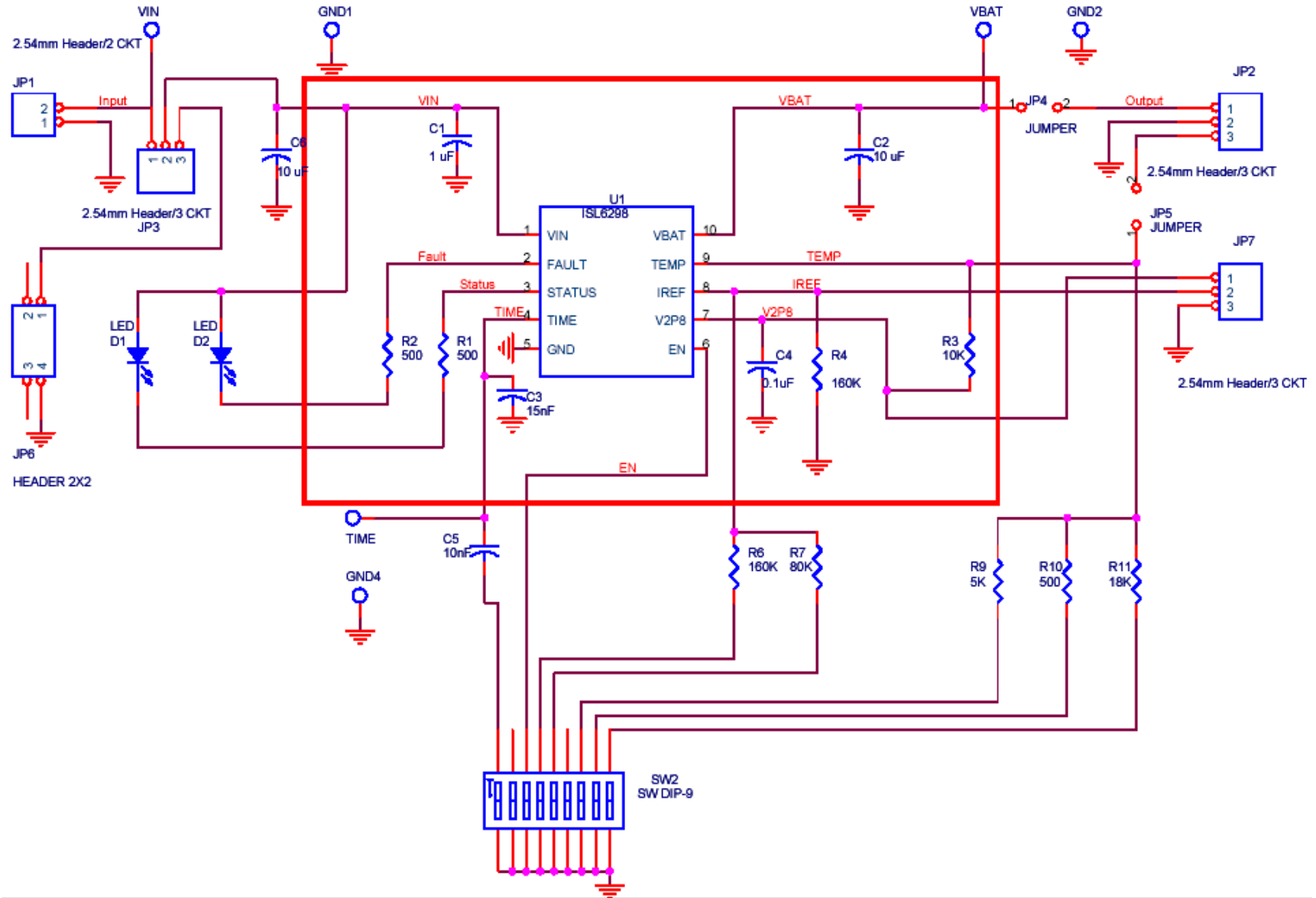
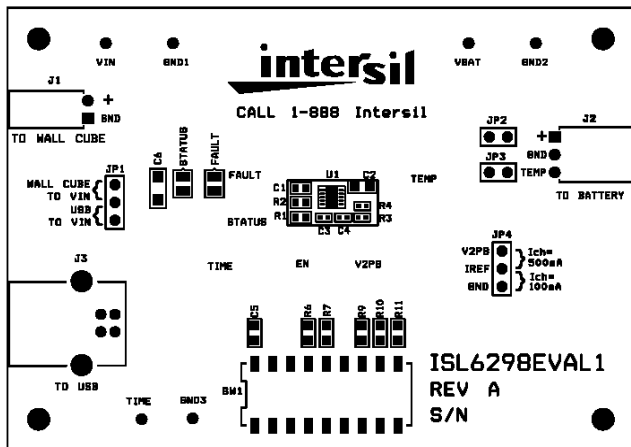

FIGURE 3. BOARD LAYOUT INFORMATION SCHEMATIC

TABLE 3. ISL6298EVAL1 BILL OF MATERIALS

ITEM	QTY	REFERENCE	PART DESCRIPTION	PCB FOOTPRINT	PART NUMBER	VENDOR
1	1	C1	1µF, 6.3V, X5R ceramic cap	0603	0603X105K6R3	Walsin
2	1	C2	10µF/6.3V, Tantalum Cap	2.05 x 1.3 x 1.2	TAJR106M006	AVX
3	1	C3	15nF/16V, X7R ceramic cap	0402	C1005X7R1C153K	TDK
4	1	C4	0.1µF/16V, Y5V ceramic cap	0402	C1005Y5V1C104ZT	TDK
5	1	C5	10nF/16V, X7R Ceramic cap	0805	C1005X7R1C103K	TDK
6	1	C6	10µF/16V, Tantalum Cap	3.2 x 1.6 x 1.6	TAJA106M016	AVX
7	1	D1	Green LED	0805	67-1553-1-ND	DigiKey
8	1	D2	Red LED	0805	67-1552-1-ND	DigiKey
9	2	R1, R2	1K, 5%	0603		Various
10	1	R3	10K, 1%	0603		Various
11	1	R4	160K, 1%	0603		Various
12	1	R6	160K, 1%	0805		Various
13	1	R7	80K, 1%	0805		Various
14	1	R9	5K, 1%	0805		Various
15	1	R10	500, 1%	0805		Various
16	1	R11	18K, 1%	0805		Various
17	1	J1	2.54mm Male Header, 2 ckt (R/A)		A23879-ND	DigiKey
18	1	J2	2.54mm Male Header, 3 ckt (R/A)		A23880-ND	DigiKey
19	2	JP1, JP4	2.54mm Male Header, 3ckt		WM6403-nd	DigiKey
20	2	JP2, JP3	2.54mm Male Header, 2 ckt		WM6402-nd	DigiKey
21	1	J3	USB receptacle, B type		787780-1-ND	DigiKey
22	1	SW1	DIP Switch, 9 Pos, SMT		CKN1323-ND	DigiKey
23	1	U1	Single-Cell Li-ion Battery Charger	10-pin, 3X3 DFN	ISL6298	Intersil
24	6	VIN, VBAT, TIME, GND1, GND2, GND3	Test Point		5002K-ND	DigiKey

PCB Layout



SILK SCREEN LAYER

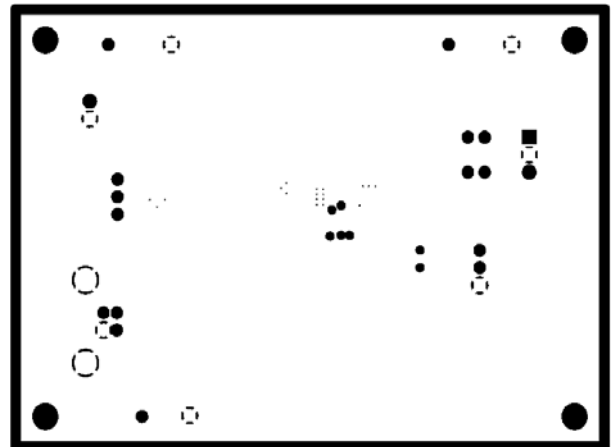

INTERNAL (LAYER 2, GND)

PCB Layout (Continued)

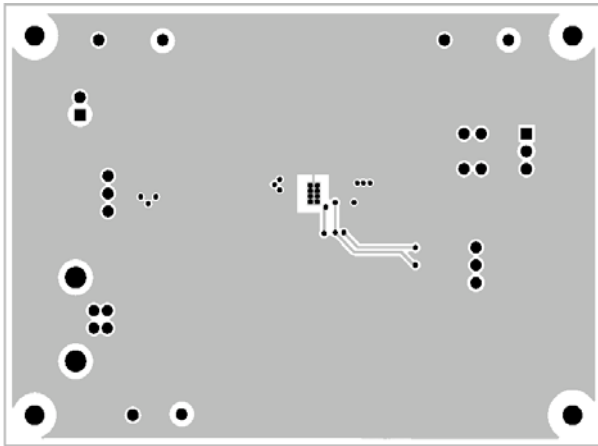

BOTTOM (LAYER 4, GND)

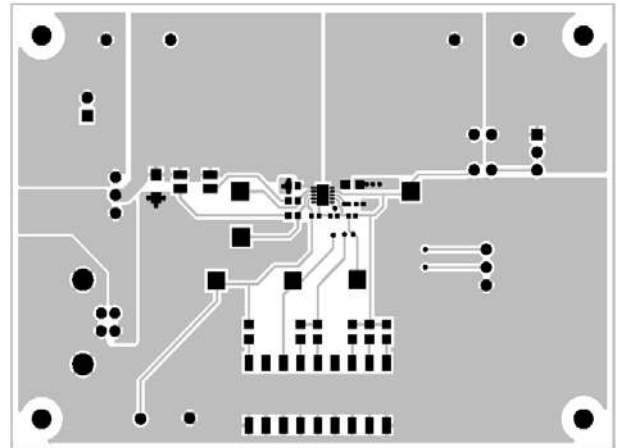

TOP (LAYER 1, SIGNAL)

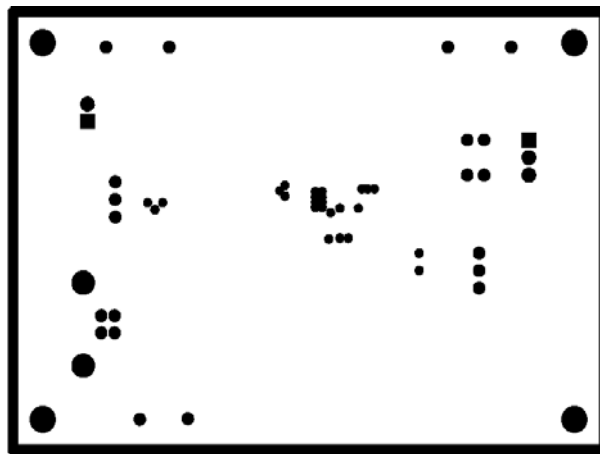

INTERNAL (LAYER 3, FLOATING)

Notice

1. Descriptions of circuits, software and other related information in this document are provided only to illustrate the operation of semiconductor products and application examples. You are fully responsible for the incorporation or any other use of the circuits, software, and information in the design of your product or system. Renesas Electronics disclaims any and all liability for any losses and damages incurred by you or third parties arising from the use of these circuits, software, or information.
2. Renesas Electronics hereby expressly disclaims any warranties against and liability for infringement or any other claims involving patents, copyrights, or other intellectual property rights of third parties, by or arising from the use of Renesas Electronics products or technical information described in this document, including but not limited to, the product data, drawings, charts, programs, algorithms, and application examples.
3. No license, express, implied or otherwise, is granted hereby under any patents, copyrights or other intellectual property rights of Renesas Electronics or others.
4. You shall not alter, modify, copy, or reverse engineer any Renesas Electronics product, whether in whole or in part. Renesas Electronics disclaims any and all liability for any losses or damages incurred by you or third parties arising from such alteration, modification, copying or reverse engineering.
5. Renesas Electronics products are classified according to the following two quality grades: "Standard" and "High Quality". The intended applications for each Renesas Electronics product depends on the product's quality grade, as indicated below.
"Standard": Computers; office equipment; communications equipment; test and measurement equipment; audio and visual equipment; home electronic appliances; machine tools; personal electronic equipment; industrial robots; etc.
"High Quality": Transportation equipment (automobiles, trains, ships, etc.); traffic control (traffic lights); large-scale communication equipment; key financial terminal systems; safety control equipment; etc.
Unless expressly designated as a high reliability product or a product for harsh environments in a Renesas Electronics data sheet or other Renesas Electronics document, Renesas Electronics products are not intended or authorized for use in products or systems that may pose a direct threat to human life or bodily injury (artificial life support devices or systems; surgical implantations; etc.), or may cause serious property damage (space system; undersea repeaters; nuclear power control systems; aircraft control systems; key plant systems; military equipment; etc.). Renesas Electronics disclaims any and all liability for any damages or losses incurred by you or any third parties arising from the use of any Renesas Electronics product that is inconsistent with any Renesas Electronics data sheet, user's manual or other Renesas Electronics document.
6. When using Renesas Electronics products, refer to the latest product information (data sheets, user's manuals, application notes, "General Notes for Handling and Using Semiconductor Devices" in the reliability handbook, etc.), and ensure that usage conditions are within the ranges specified by Renesas Electronics with respect to maximum ratings, operating power supply voltage range, heat dissipation characteristics, installation, etc. Renesas Electronics disclaims any and all liability for any malfunctions, failure or accident arising out of the use of Renesas Electronics products outside of such specified ranges.
7. Although Renesas Electronics endeavors to improve the quality and reliability of Renesas Electronics products, semiconductor products have specific characteristics, such as the occurrence of failure at a certain rate and malfunctions under certain use conditions. Unless designated as a high reliability product or a product for harsh environments in a Renesas Electronics data sheet or other Renesas Electronics document, Renesas Electronics products are not subject to radiation resistance design. You are responsible for implementing safety measures to guard against the possibility of bodily injury, injury or damage caused by fire, and/or danger to the public in the event of a failure or malfunction of Renesas Electronics products, such as safety design for hardware and software, including but not limited to redundancy, fire control and malfunction prevention, appropriate treatment for aging degradation or any other appropriate measures. Because the evaluation of microcomputer software alone is very difficult and impractical, you are responsible for evaluating the safety of the final products or systems manufactured by you.
8. Please contact a Renesas Electronics sales office for details as to environmental matters such as the environmental compatibility of each Renesas Electronics product. You are responsible for carefully and sufficiently investigating applicable laws and regulations that regulate the inclusion or use of controlled substances, including without limitation, the EU RoHS Directive, and using Renesas Electronics products in compliance with all these applicable laws and regulations. Renesas Electronics disclaims any and all liability for damages or losses occurring as a result of your noncompliance with applicable laws and regulations.
9. Renesas Electronics products and technologies shall not be used for or incorporated into any products or systems whose manufacture, use, or sale is prohibited under any applicable domestic or foreign laws or regulations. You shall comply with any applicable export control laws and regulations promulgated and administered by the governments of any countries asserting jurisdiction over the parties or transactions.
10. It is the responsibility of the buyer or distributor of Renesas Electronics products, or any other party who distributes, disposes of, or otherwise sells or transfers the product to a third party, to notify such third party in advance of the contents and conditions set forth in this document.
11. This document shall not be reprinted, reproduced or duplicated in any form, in whole or in part, without prior written consent of Renesas Electronics.
12. Please contact a Renesas Electronics sales office if you have any questions regarding the information contained in this document or Renesas Electronics products.
(Note 1) "Renesas Electronics" as used in this document means Renesas Electronics Corporation and also includes its directly or indirectly controlled subsidiaries.
(Note 2) "Renesas Electronics product(s)" means any product developed or manufactured by or for Renesas Electronics.

(Rev.4.0-1 November 2017)



SALES OFFICES

Renesas Electronics Corporation

<http://www.renesas.com>

Refer to "<http://www.renesas.com/>" for the latest and detailed information.

Renesas Electronics America Inc.
1001 Murphy Ranch Road, Milpitas, CA 95035, U.S.A.
Tel: +1-408-432-8888, Fax: +1-408-434-5351

Renesas Electronics Canada Limited
9251 Yonge Street, Suite 8309 Richmond Hill, Ontario Canada L4C 9T3
Tel: +1-905-237-2004

Renesas Electronics Europe Limited
Dukes Meadow, Millboard Road, Bourne End, Buckinghamshire, SL8 5FH, U.K
Tel: +44-1628-651-700, Fax: +44-1628-651-804

Renesas Electronics Europe GmbH
Arcadiastrasse 10, 40472 Düsseldorf, Germany
Tel: +49-211-6503-0, Fax: +49-211-6503-1327

Renesas Electronics (China) Co., Ltd.
Room 1709 Quantum Plaza, No.27 ZhichunLu, Haidian District, Beijing, 100191 P. R. China
Tel: +86-10-8235-1155, Fax: +86-10-8235-7679

Renesas Electronics (Shanghai) Co., Ltd.
Unit 301, Tower A, Central Towers, 555 Langao Road, Putuo District, Shanghai, 200333 P. R. China
Tel: +86-21-2226-0888, Fax: +86-21-2226-0999

Renesas Electronics Hong Kong Limited
Unit 1601-1611, 16/F., Tower 2, Grand Century Place, 193 Prince Edward Road West, Mongkok, Kowloon, Hong Kong
Tel: +852-2265-6688, Fax: +852-2886-9022

Renesas Electronics Taiwan Co., Ltd.
13F, No. 363, Fu Shing North Road, Taipei 10543, Taiwan
Tel: +886-2-8175-9600, Fax: +886-2-8175-9670

Renesas Electronics Singapore Pte. Ltd.
80 Bendemeer Road, Unit #06-02 Hyflux Innovation Centre, Singapore 339949
Tel: +65-6213-0200, Fax: +65-6213-0300

Renesas Electronics Malaysia Sdn.Bhd.
Unit 1207, Block B, Menara Amcorp, Amcorp Trade Centre, No. 18, Jln Persiaran Barat, 46050 Petaling Jaya, Selangor Darul Ehsan, Malaysia
Tel: +60-3-7955-9390, Fax: +60-3-7955-9510

Renesas Electronics India Pvt. Ltd.
No.777C, 100 Feet Road, HAL 2nd Stage, Indiranagar, Bangalore 560 038, India
Tel: +91-80-67208700, Fax: +91-80-67208777

Renesas Electronics Korea Co., Ltd.
17F, KAMCO Yangjae Tower, 262, Gangnam-daero, Gangnam-gu, Seoul, 06265 Korea
Tel: +82-2-558-3737, Fax: +82-2-558-5338