

LOC	DIST	REVISIONS			
DF	AO	REV	DATE	BY	APPV
		B	05FEB2013	MGM	CT

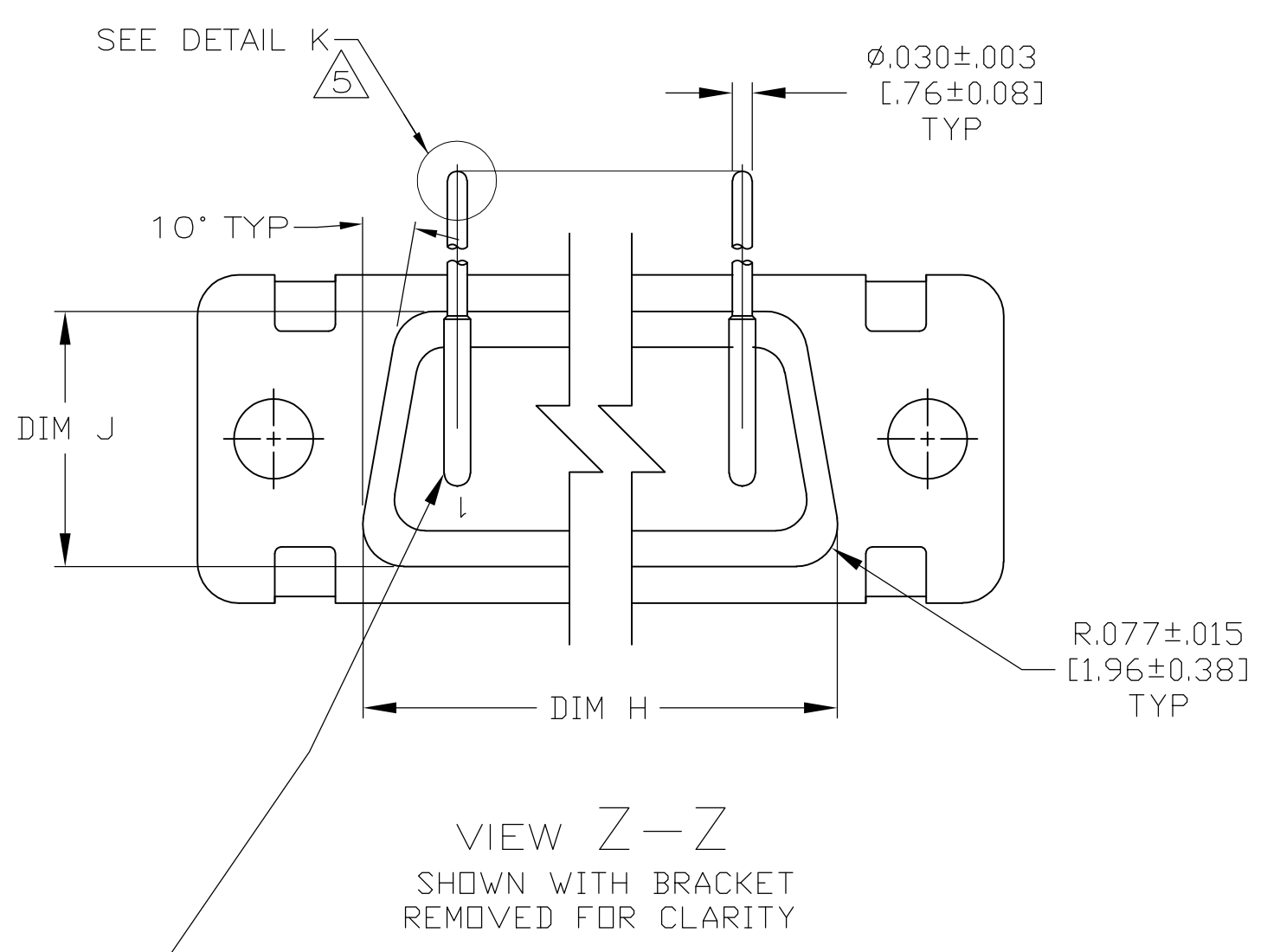
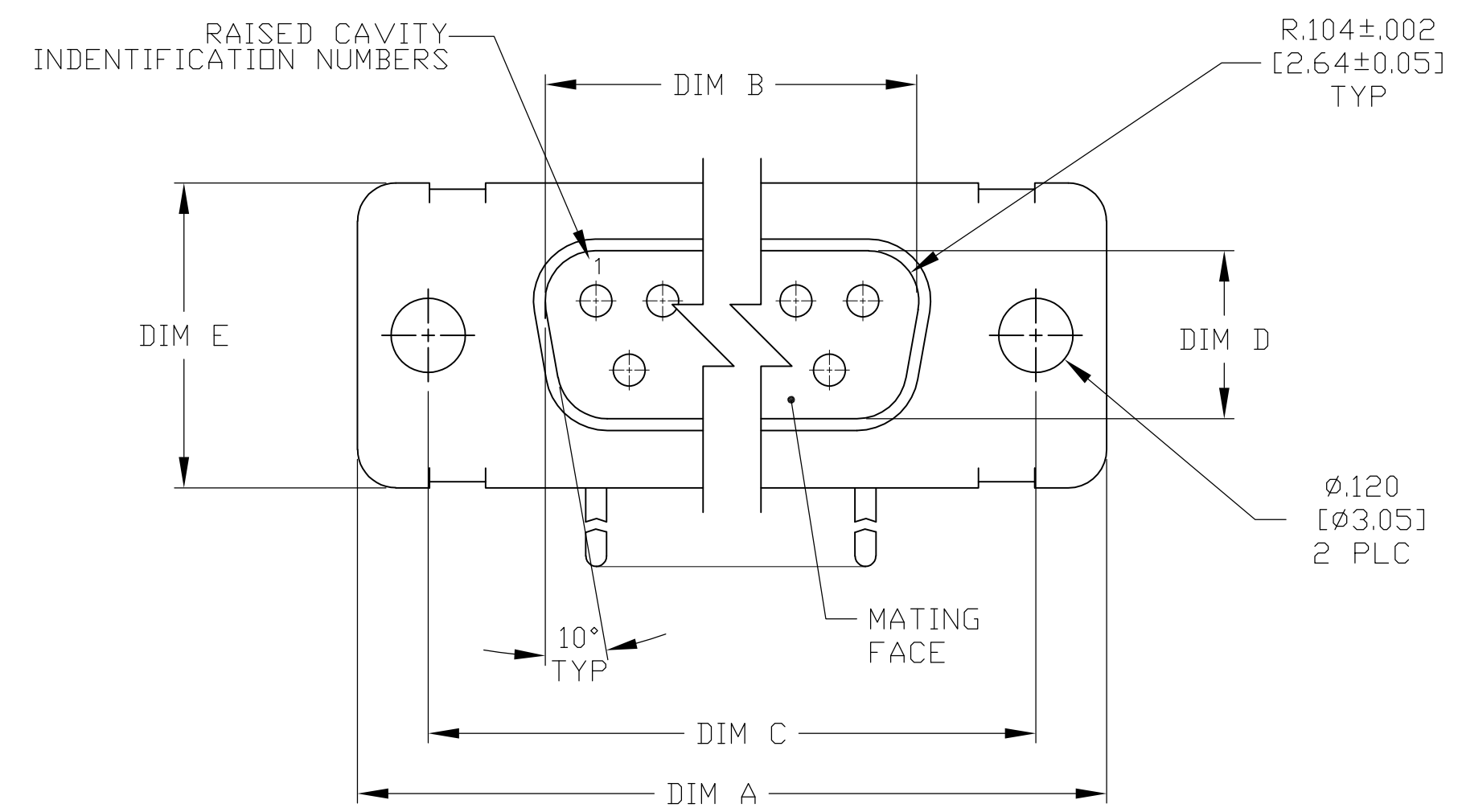

VIEW Z-Z
SHOWN WITH BRACKET REMOVED FOR CLARITY

CONTACT (QTY = NO. OF POSN)
MATL: BRASS PER ASTM-B-16, OR BERYLLIUM COPPER PER ASTM-B-194
FINISH: GOLD PER ASTM-B-488, TYPE II, GRADE C, CLASS 1.27 IN CONTACT MATING AREA, .000010 [0.0003] MIN THK GOLD PER ASTM-B-488 OVER .000050 [0.0013] MIN THK NICKEL PER SAE-AMS-QQ-N-290 ON CONTACT BODY

- SEE SHEET 2 FOR RECOMMENDED P.C. BOARD LAYOUT. TRUE POSITION TOLERANCE FOR P.C. BOARD LAYOUT IS .010 [0.25] AT MAX MATERIAL CONDITION. SUGGESTED BOARD THICKNESS IS .062 [1.57]
- THE CONNECTORS DESCRIBED IN THIS DOCUMENT MEET THE REQUIREMENTS OF MIL-C-24308 AND MATE WITH ANY RECEPTACLE CONNECTOR WITH SAME INSERT ARRANGEMENT.
- MARKED WITH .047 [1.19]-.062 [1.57] HIGH CHARACTERS. FAR SIDE REFERS TO THE WIDE SIDE OF THE KEYSTONE. NEAR SIDE REFERS TO THE NARROW SIDE OF THE KEYSTONE. IF THE SHELL IS TOO SMALL FOR THE ENTIRE MARKING MARKING SHALL BE SPLIT AS FOLLOWS:
 - "M24308" ON FRONT SHELL, FAR SIDE.
 - SLASH SHEET AND DASH NUMBER ON REAR SHELL, FAR SIDE.
 - "MFG'S" (NAME, BRAND OR LOGO) AND DATE CODE ON FRONT SHELL, NEAR SIDE.
 - MFG'S PART NUMBER ON REAR SHELL, NEAR SIDE.
- REQUIREMENT FOR FULL PIN DIAMETER EXTENSION:
 - .159 [4.04] MIN, SHELL SIZES 1 AND 2.
 - .150 [3.81] MIN, SHELL SIZES 3 AND 4.
- SOLDER DIPPED PER J-STD-001 WITH Sn63 SOLDER PER J-STD-006 IN THE ENTIRE AREA OF DIMENSION SHOWN. (1757839-6 THRU -10 ONLY.)
- MEETS SOLDERABILITY PER MIL-STD-202 METHOD 208.

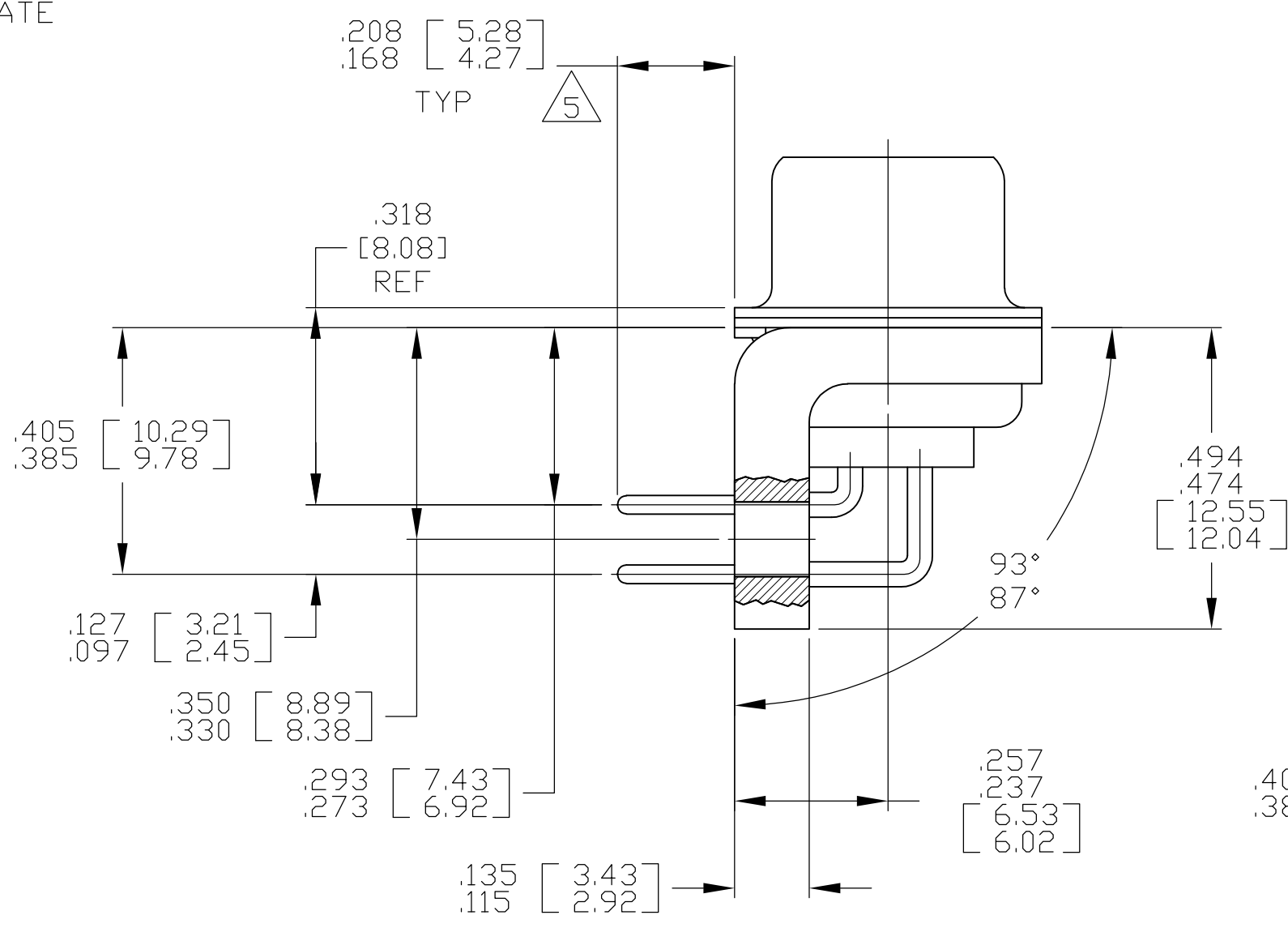
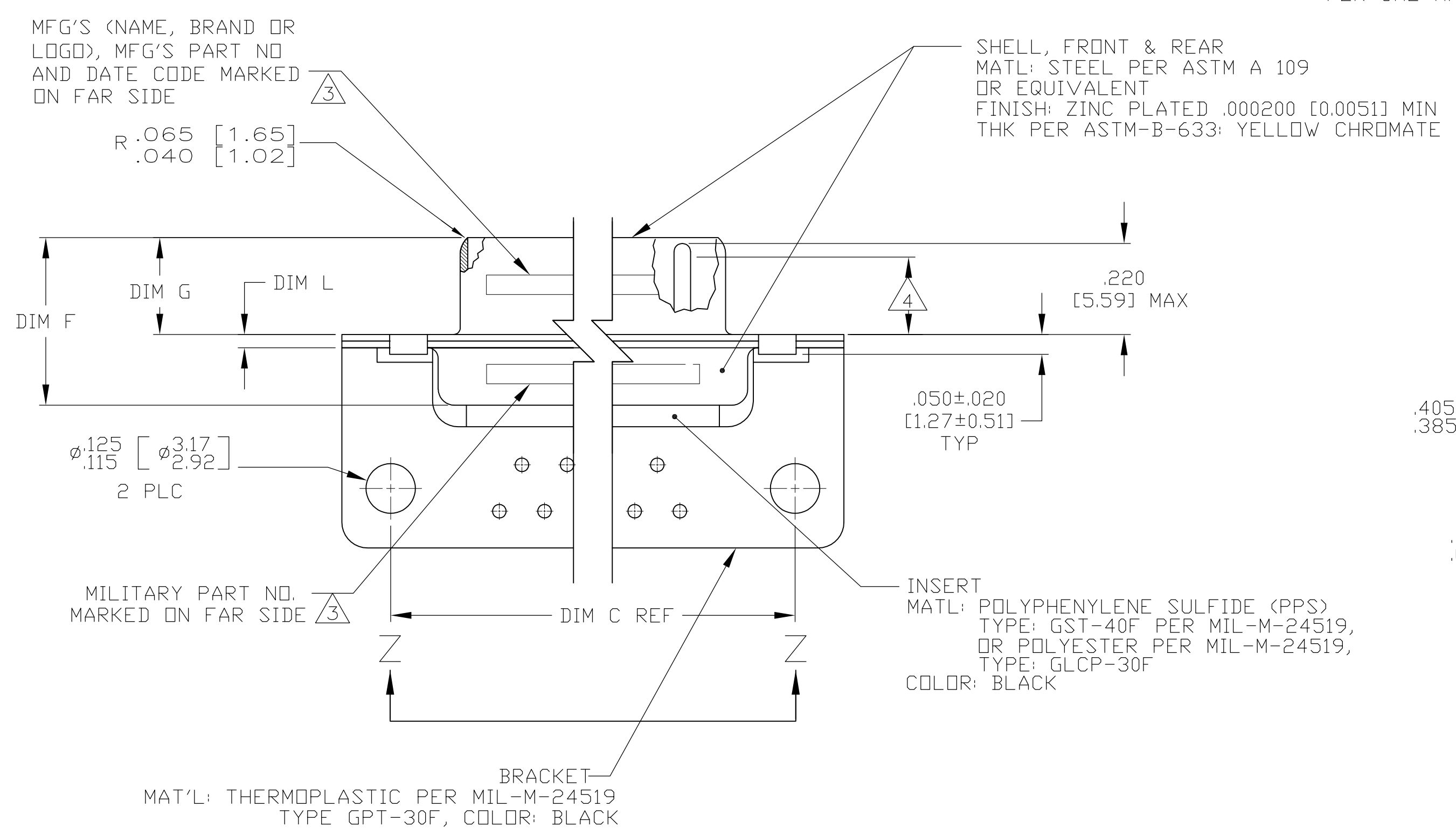

SHELL SIZES 1 THRU 4 CONTACT CONFIGURATION

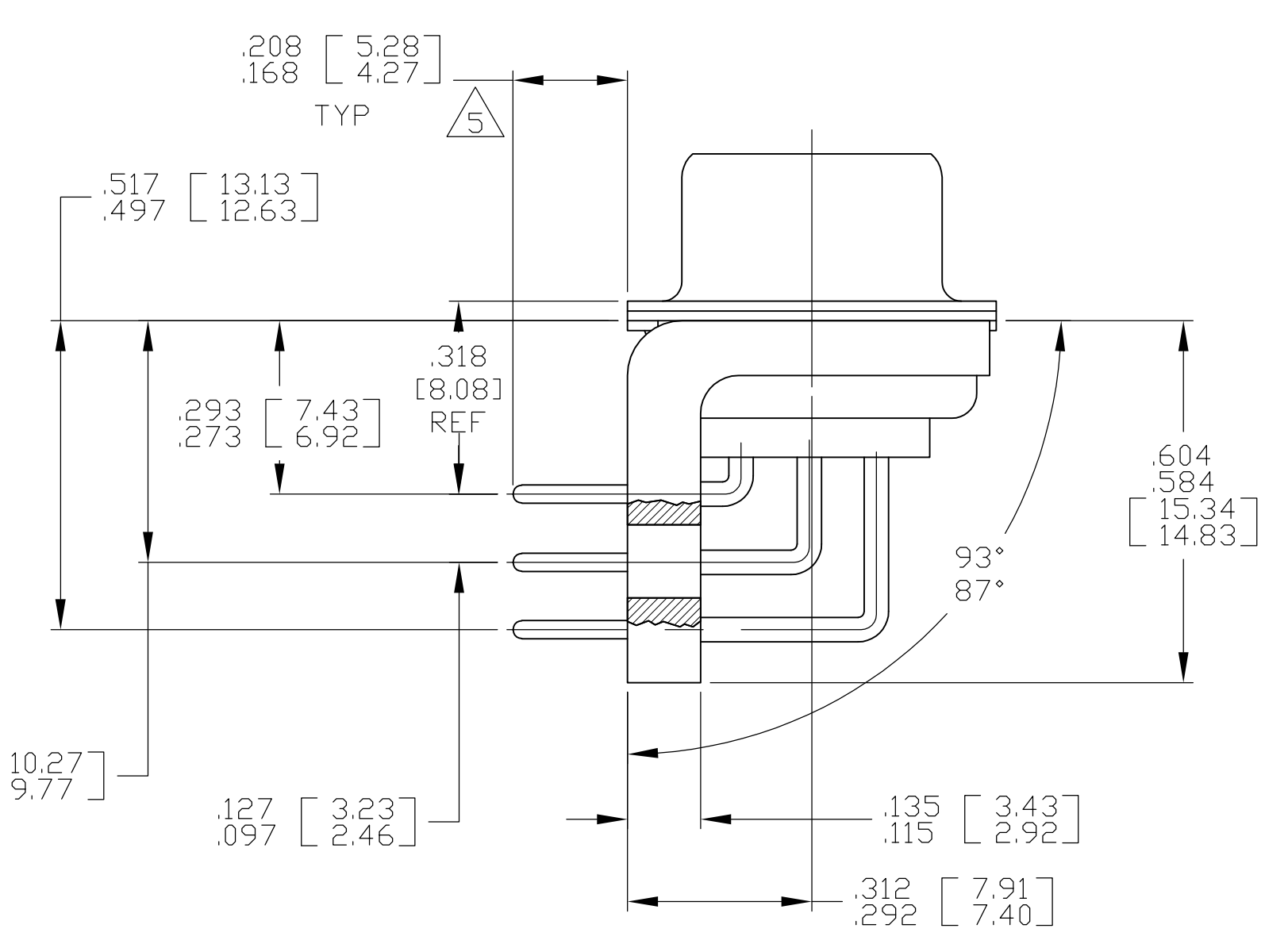

SHELL SIZE 5 CONTACT CONFIGURATION

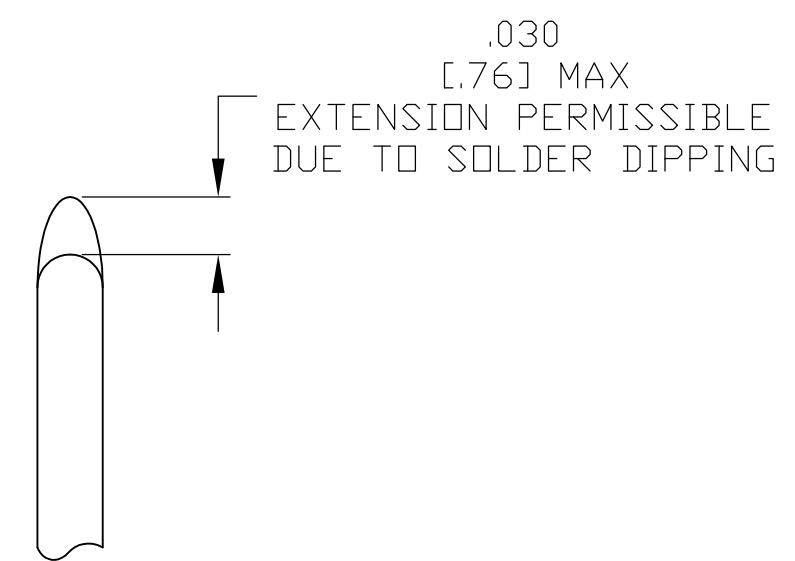

DETAIL K
SCALE 10:1
FOR 1757839-6 THRU -10 ONLY

.049 [1.24]	.544 [13.82]	2.188 [55.58]	.236 [5.99]	.436 [11.07]	.620 [15.75]	.446 [11.33]	2.411 [61.24]	2.084 [52.55]	2.650 [67.31]	MS18277-1	50	5	M24308/24-53Z	1757839-5	1-1757839-0
.029 [0.74]	.524 [13.31]	2.168 [55.07]	.224 [5.69]	.416 [10.57]	.590 [14.99]	.436 [11.07]	2.401 [60.99]	2.074 [52.30]	2.620 [66.55]	MS18276-1	37	4	M24308/24-52Z	1757839-4	1757839-9
.049 [1.24]	.432 [10.97]	2.282 [57.96]	.236 [5.99]	.436 [11.07]	.509 [12.93]	.334 [8.48]	2.505 [63.63]	2.187 [54.97]	2.744 [69.70]	MS18275-1	25	3	M24308/24-51Z	1757839-3	1757839-8
.029 [0.74]	.412 [10.46]	2.262 [57.45]	.224 [5.69]	.416 [10.57]	.479 [12.17]	.324 [8.23]	2.495 [63.37]	2.177 [54.71]	2.714 [68.94]	MS18274-1	15	2	M24308/24-50Z	1757839-2	1757839-7
.049 [1.24]	.432 [10.97]	1.635 [41.53]	.236 [5.99]	.436 [11.07]	.509 [12.93]	.334 [8.48]	1.857 [47.17]	1.539 [38.51]	2.103 [53.42]	MS18273-1	9	1	M24308/24-49Z	1757839-1	1757839-6
.029 [0.74]	.412 [10.46]	1.615 [41.02]	.224 [5.69]	.416 [10.57]	.479 [12.17]	.324 [8.23]	1.847 [46.91]	1.529 [38.25]	2.073 [52.65]	MS18272-1	9	1	M24308/24-48Z	1757839-1	1757839-6
.040 [1.02]	.432 [10.97]	1.093 [27.76]	.238 [6.05]	.432 [10.97]	.509 [12.93]	.334 [8.48]	1.317 [33.45]	.999 [24.79]	1.556 [39.52]	MS18271-1	15	2	M24308/24-50Z	1757839-2	1757839-7
.020 [0.51]	.412 [10.46]	1.073 [27.25]	.229 [5.82]	.412 [10.46]	.479 [12.17]	.324 [8.23]	1.307 [33.20]	.989 [24.54]	1.526 [38.76]	MS18270-1	9	1	M24308/24-49Z	1757839-1	1757839-6
.049 [1.24]	.544 [13.82]	2.188 [55.58]	.236 [5.99]	.436 [11.07]	.620 [15.75]	.446 [11.33]	2.411 [61.24]	2.084 [52.55]	2.650 [67.31]	MS18277-1	50	5	M24308/24-53Z	1757839-5	1757839-5
.029 [0.74]	.524 [13.31]	2.168 [55.07]	.224 [5.69]	.416 [10.57]	.590 [14.99]	.436 [11.07]	2.401 [60.99]	2.074 [52.30]	2.620 [66.55]	MS18276-1	37	4	M24308/24-52Z	1757839-4	1757839-9
.049 [1.24]	.432 [10.97]	2.282 [57.96]	.236 [5.99]	.436 [11.07]	.509 [12.93]	.334 [8.48]	2.505 [63.63]	2.187 [54.97]	2.744 [69.70]	MS18275-1	25	3	M24308/24-51Z	1757839-3	1757839-8
.029 [0.74]	.412 [10.46]	2.262 [57.45]	.224 [5.69]	.416 [10.57]	.479 [12.17]	.324 [8.23]	2.495 [63.37]	2.177 [54.71]	2.714 [68.94]	MS18274-1	15	2	M24308/24-50Z	1757839-2	1757839-7
.049 [1.24]	.432 [10.97]	1.635 [41.53]	.236 [5.99]	.436 [11.07]	.509 [12.93]	.334 [8.48]	1.857 [47.17]	1.539 [38.51]	2.103 [53.42]	MS18273-1	9	1	M24308/24-49Z	1757839-1	1757839-6
.029 [0.74]	.412 [10.46]	1.615 [41.02]	.224 [5.69]	.416 [10.57]	.479 [12.17]	.324 [8.23]	1.847 [46.91]	1.529 [38.25]	2.073 [52.65]	MS18272-1	9	1	M24308/24-48Z	1757839-1	1757839-6
.040 [1.02]	.432 [10.97]	1.093 [27.76]	.238 [6.05]	.432 [10.97]	.509 [12.93]	.334 [8.48]	1.317 [33.45]	.999 [24.79]	1.556 [39.52]	MS18271-1	15	2	M24308/24-50Z	1757839-2	1757839-7
.020 [0.51]	.412 [10.46]	1.073 [27.25]	.229 [5.82]	.412 [10.46]	.479 [12.17]	.324 [8.23]	1.307 [33.20]	.989 [24.54]	1.526 [38.76]	MS18270-1	9	1	M24308/24-49Z	1757839-1	1757839-6

THIS DRAWING IS A CONTROLLED DOCUMENT.		DATE: 2-23-06	BY: C.C. THOMAS	APPV: D. MILLER
DIMENSIONS: INCHES		TOLERANCES UNLESS OTHERWISE SPECIFIED:		
0 PLC ± .005		1 PLC ± .005		
2 PLC ± .005		3 PLC ± .005		
4 PLC ± .005		ANGLES ± .1°		
MATERIAL: SEE CALLOUTS	FINISH: SEE CALLOUTS	WEIGHT: —	SIZE: A1	CAGE CODE: 00779
CUSTOMER DRAWING		SCALE: 4:1	SHEET: 1 OF 2	REV: B



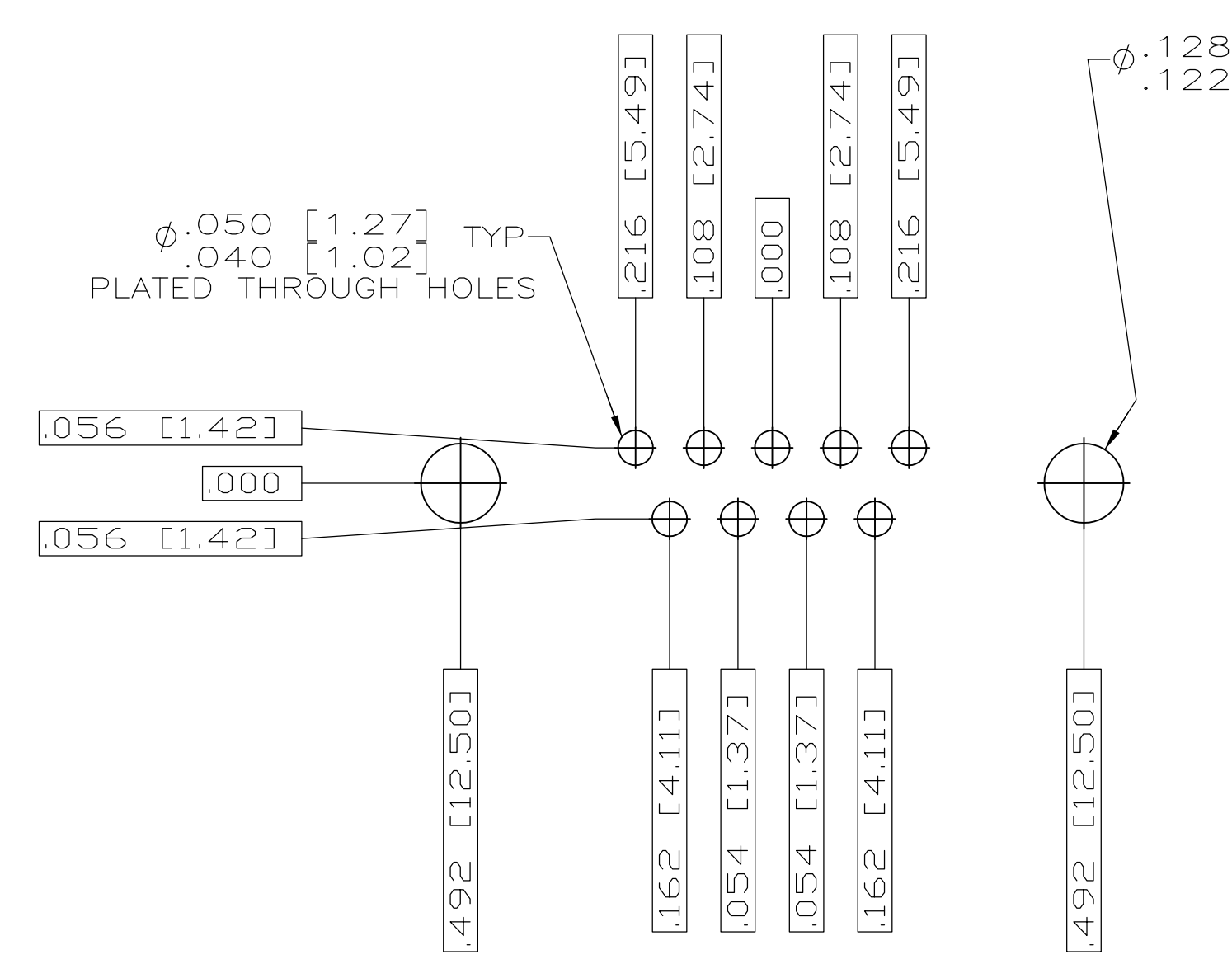

RECOMMENDED P.C. BOARD LAYOUT
SHELL SIZE 1 (9 POSITION) Δ

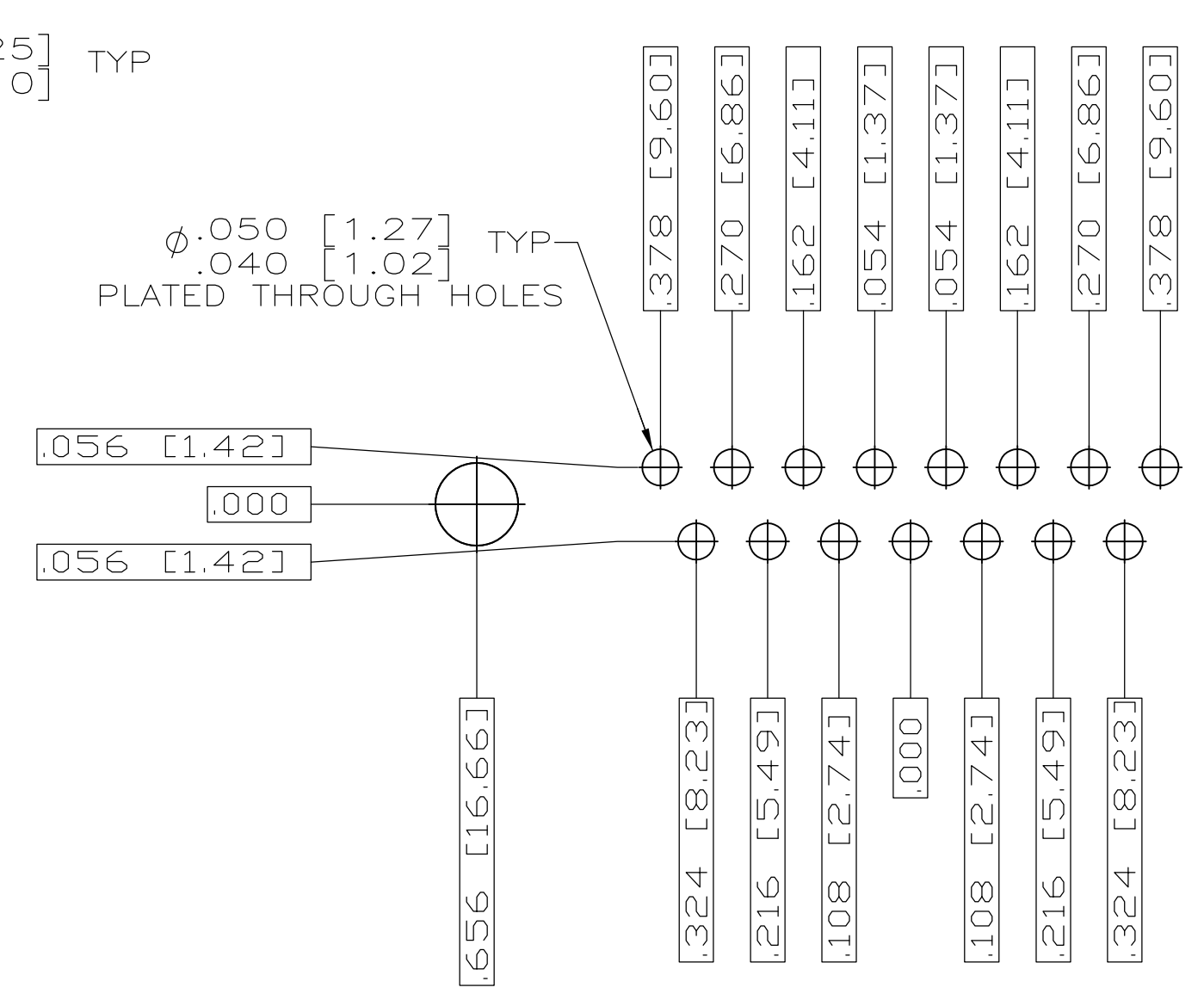

RECOMMENDED P.C. BOARD LAYOUT
SHELL SIZE 2 (15 POSITION) Δ

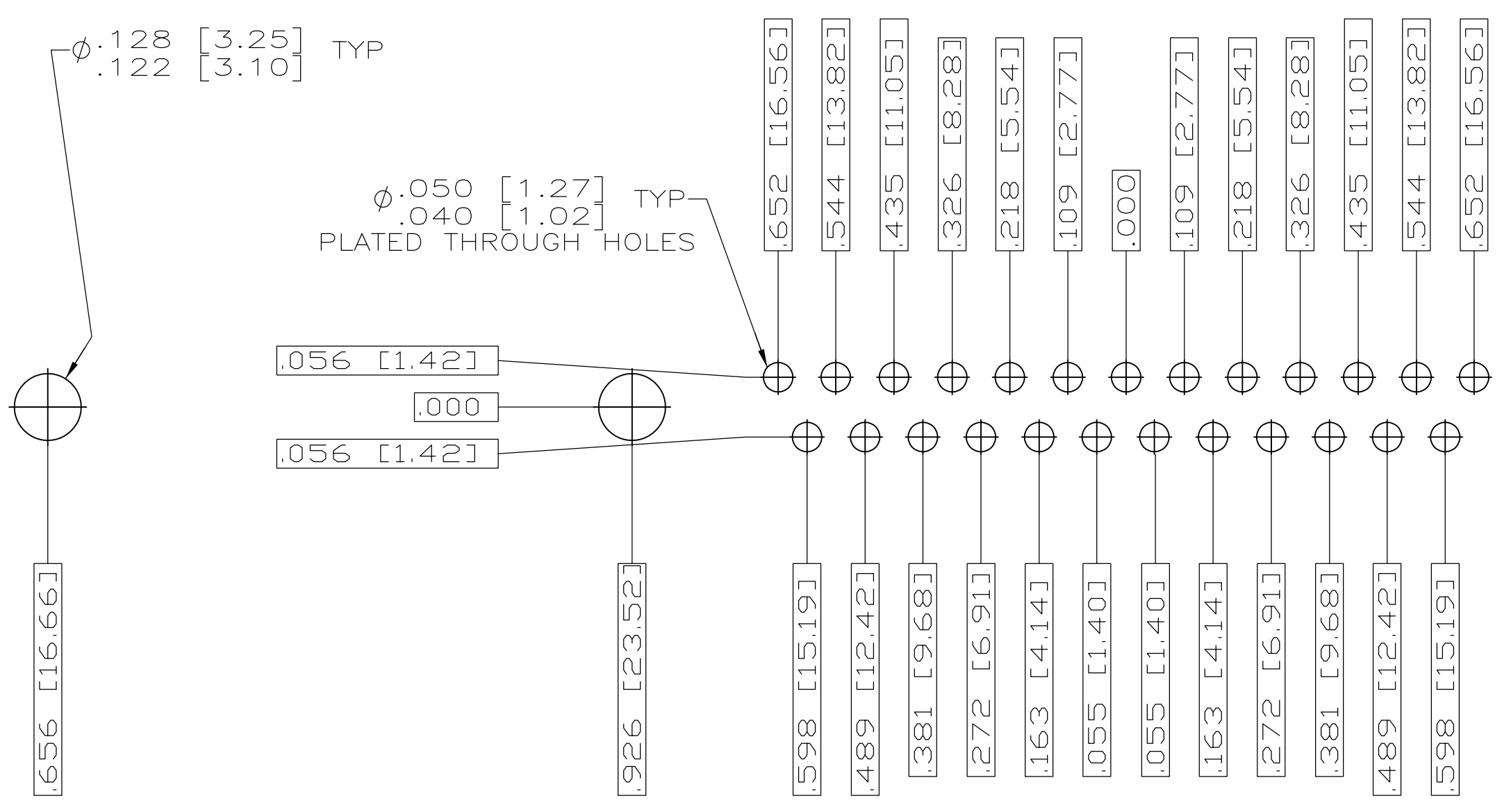

RECOMMENDED P.C. BOARD LAYOUT
SHELL SIZE 3 (25 POSITION) Δ

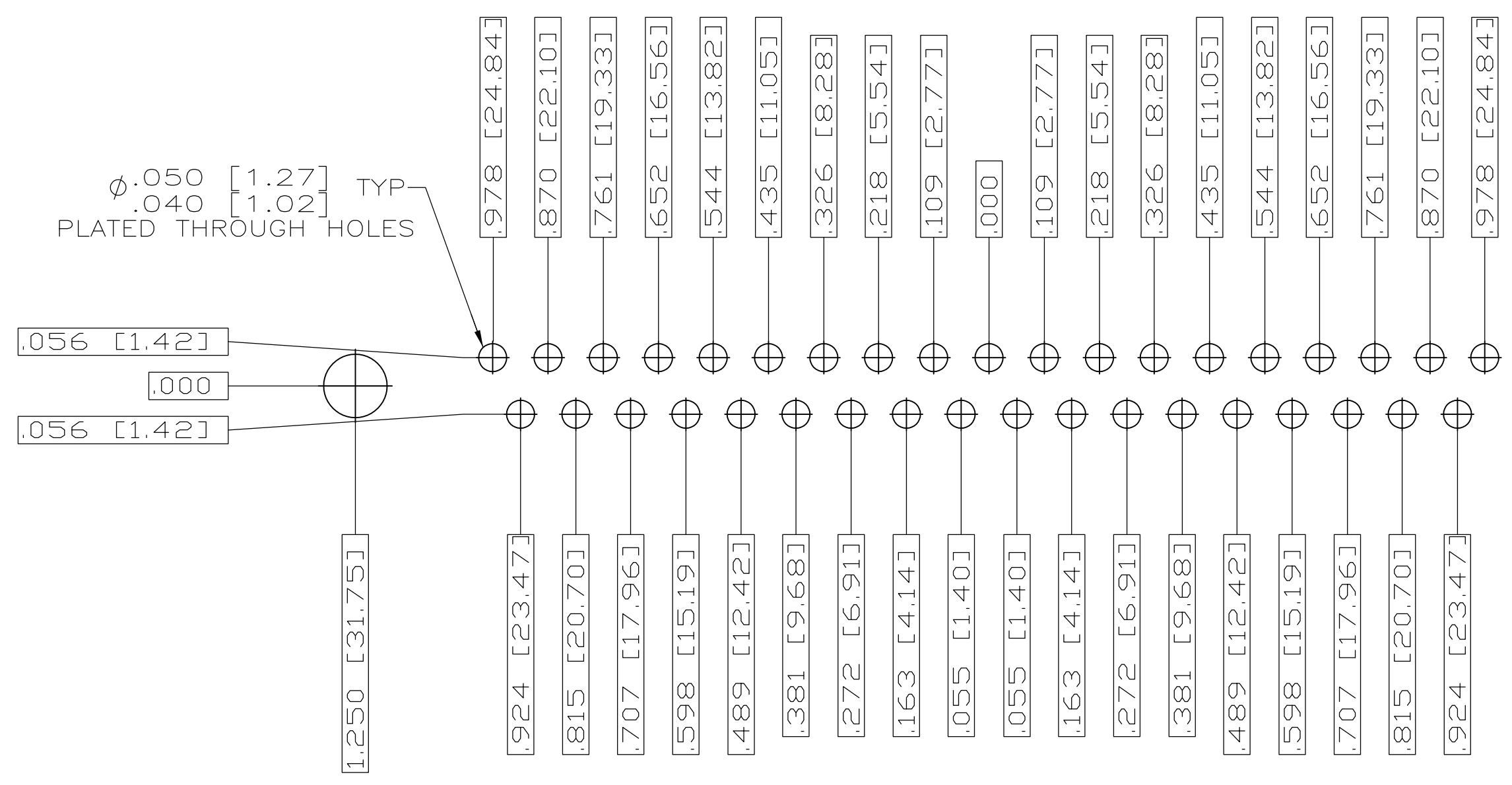

RECOMMENDED P.C. BOARD LAYOUT
SHELL SIZE 4 (37 POSITION) Δ

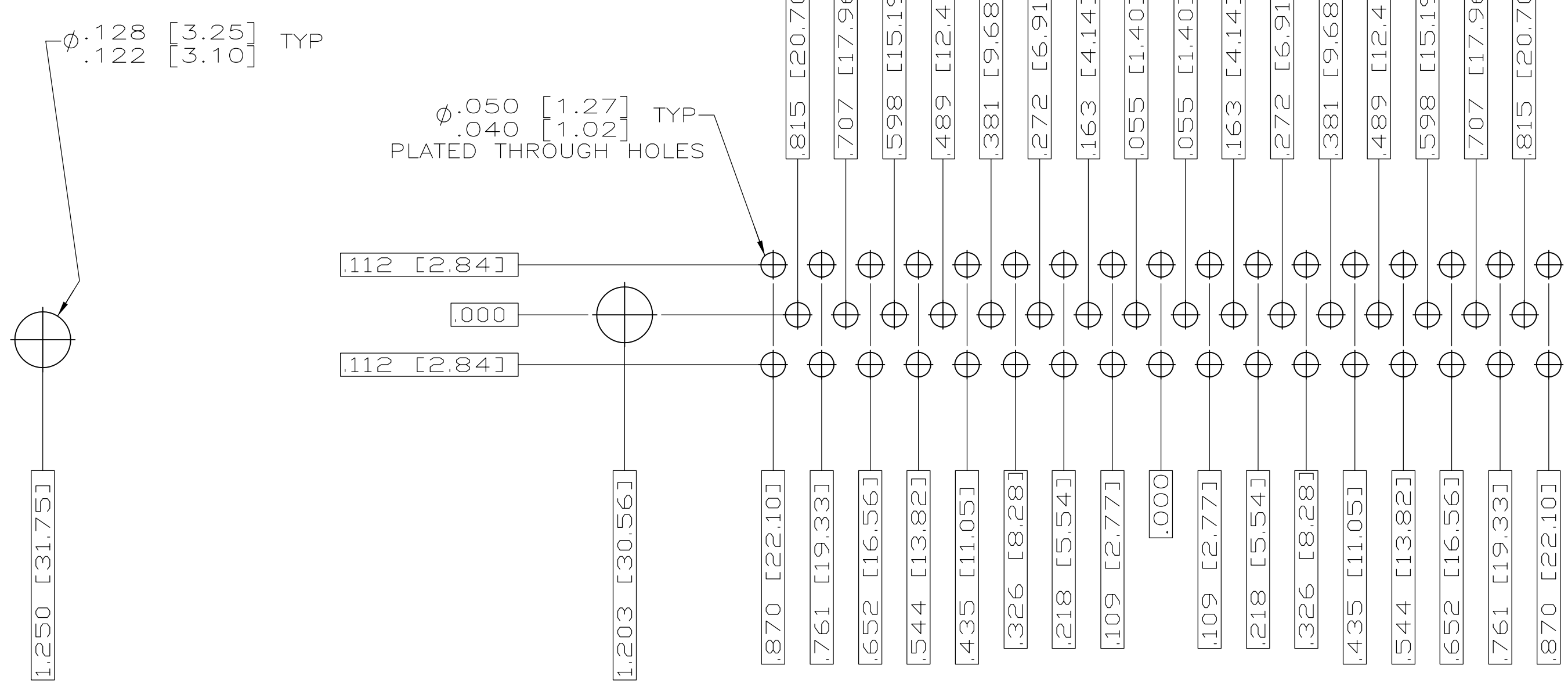

RECOMMENDED P.C. BOARD LAYOUT
SHELL SIZE 5 (50 POSITION) Δ

THIS DRAWING IS A CONTROLLED DOCUMENT.		DN C.C.THOMAS 2-23-06	TE Connectivity
DIMENSIONS: INCHES		CHK D.HOFFMAN 2-23-06	
TOLERANCES UNLESS OTHERWISE SPECIFIED:		APVD D.MILLER 2-23-06	NAME PLUG ASSY,AMPLIMITE RIGHT ANGLE,SERIES 109,SIZE 1 THRU 5
		FINISH SEE CALLOUTS	APPLICATION SPEC
MATERIAL SEE CALLOUTS		WEIGHT -	SIZE A1
		CUSTOMER DRAWING	SCALE 4:1 SHEET 2 OF 2 REV B