

© - TE Connectivity. All Rights Reserved.

REVISIONS				
P	LTR	DESCRIPTION	DATE	APVD
	L4	REVISED PER ECN-22-156403	06JUN2022	RK CSD

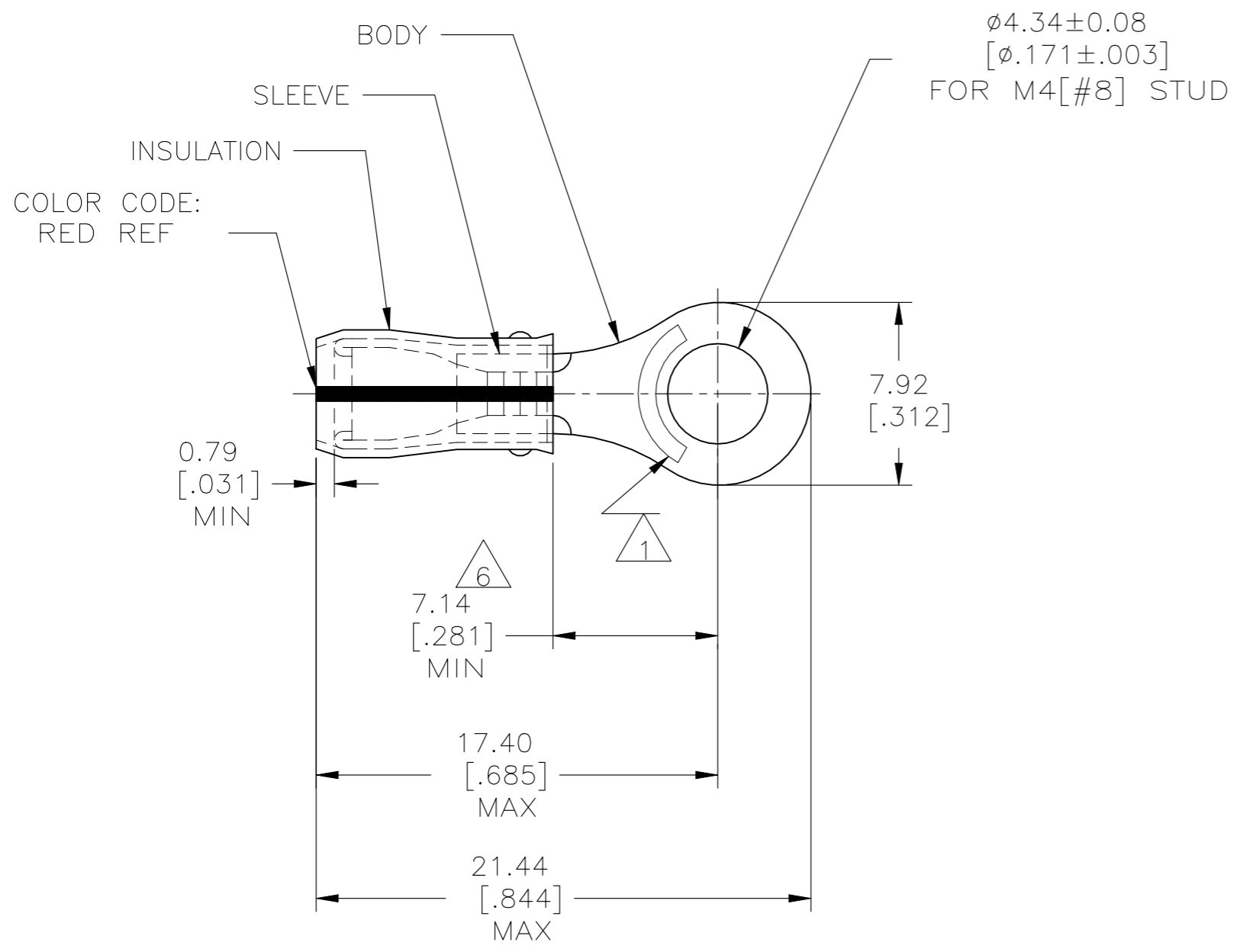

- 1 STAMP AMP 22-18* APPROX AS SHOWN
22-16 TERMINALS ARE STAMPED 22-18 IN
ACCORDANCE WITH MILITARY SPEC SAE AS7928
COMMERCIAL WIRE RANGE IS 22-16.
- 2 WIRE INSULATION DIA: 2.03-3.18 [.080-.125]
- 3 TONGUE MATERIAL THK: 0.79±0.05 [.031±.002]
- 4 BODY & SLEEVE: TIN/LEAD (93-7) PLATE PER
ASTM B545, (3% MIN LEAD CONTENT)
- 5 BODY & SLEEVE- CU PER ASTM B152
INSULATION - PVF2, COLOR - NATURAL
- 6 DIMENSION APPLIES FROM EDGE OF METAL WIRE
BARREL TO CENTER OF STUD HOLE.

-	100	LOOSE PIECE, BOX	8-53408-1
-	5000	ON TAPE, REEL	53408-2
M7928/4-149, CLASS 1 M7928/13-149, CLASS 1	1000	LOOSE PIECE	53408-1
MILITARY P/N & CLASS	QTY	PACKAGE TYPE	PART NO.

AMP INCORPORATED CUSTOMER SERVICE SYSTEMS		MAX RECOMMENDED OPERATING TEMPERATURE: 150°C[302°F] MAX	THIS DRAWING IS A CONTROLLED DOCUMENT.		DWN DK SCHRUM 06/16/93	TE Connectivity NAME TERMINAL, RING TONGUE, PVF2, P.I.D.G. WIRE SIZE: 22-16 AWG				
FOR ADDITIONAL PRODUCT INFORMATION OR COPIES OF DRAWINGS AND TECHNICAL DOCUMENTS	PRODUCT INFORMATION CENTER 1-800-522-6752	VOLTAGE RATING: N/A	DIMENSIONS: mm [INCHES]	TOLERANCES UNLESS OTHERWISE SPECIFIED:	CHK RE HERSEY 7/6/93					APVD M ELLIS 7/6/93
FOR APPLICATION TOOLING INFORMATION	TOOLING ASSISTANCE CENTER 1-800-722-1111	CIRCULAR MIL AREA: 0.26-1.65mm²[509-3260] STRANDED		0 PLC ± - 1 PLC ± - 2 PLC ± 0.20[.008] 3 PLC ± - 4 PLC ± - ANGLES ± -	PRODUCT SPEC -	APPLICATION SPEC NOT AVAILABLE	A3	00779	C-53408	-
FOR ORDER ENTRY	1-800-526-5142	THIS DRAWING IS A CONTROLLED DOCUMENT FOR AMP INCORPORATED. IT IS SUBJECT TO CHANGE AND THE CONTROLLING ENGINEERING ORGANIZATION SHOULD BE CONTACTED FOR THE LATEST REVISION.	MATERIAL - 5	FINISH - 4	WEIGHT -	CUSTOMER DRAWING	SCALE 4:1	SHEET 1 OF 1	REV L4	