

# SPECIFICATIONS

PARAMETERS	VALUES	UNITS
RATED INPUT POWER	20	W
MAX INPUT POWER	40	W
IMPEDANCE	8± 15%	OHM
RESONANT FREQUENCY	480± 20%	Hz
AVG. SPL 2.83V/0.1M ON 4MM THICK PLA PANEL (AVG 0.5, 1.0, 2.0, AND 5.0 kHz)	104	dBA
FREQUENCY RANGE (MATERIAL DEPENDANT)	60~ 20,000	Hz
MAGNET MATERIAL	NdFeB	-
OPERATING TEMPERATURE	-20~ +60	°C
WEIGHT	114	grams

THIS DOCUMENT CONTAINS DATA PROPRIETARY TO PROJECTS UNLIMITED, INC. ANY USE OR REPRODUCTION, IN ANY FORM, WITHOUT PRIOR WRITTEN PERMISSION OF PROJECTS UNLIMITED, INC. IS PROHIBITED.  
©2003, Projects Unlimited Inc.

# REVISION HISTORY

LTR	DESCRIPTION	DATE	APPROVED
-	RELEASED FROM ENGINEERING	1/31/17	
A	REVISED THREADS ON MAGNET FROM M4 TO M3	3/6/2020	M.V.

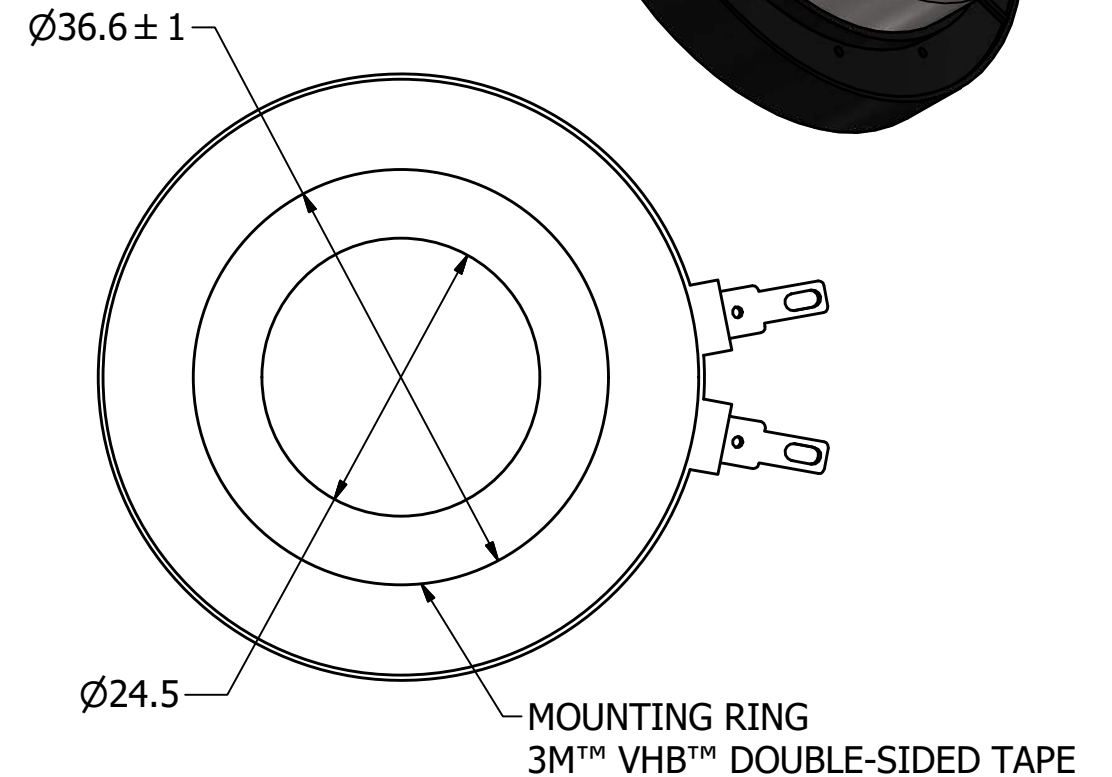
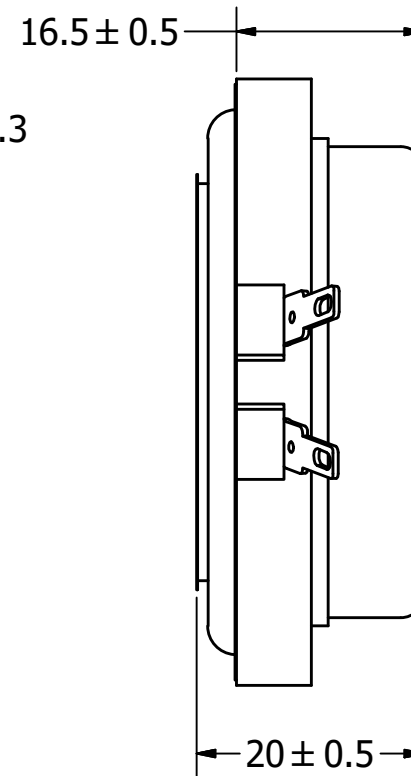
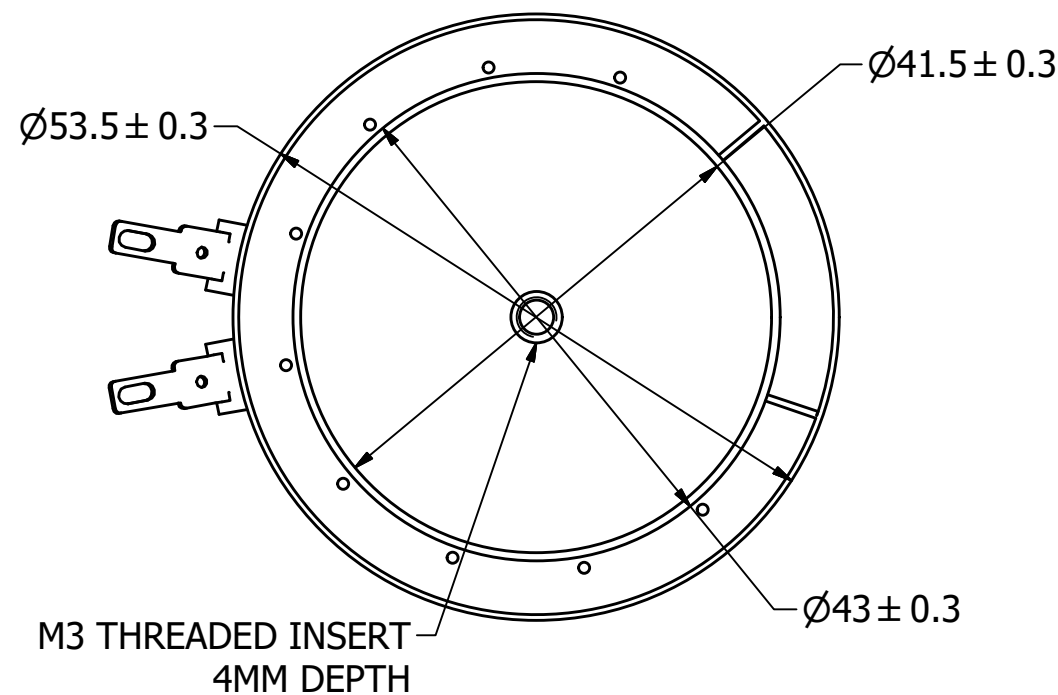

## NOTES:

1. ALL DIMENSIONS ARE IN MILLIMETERS.
2. SPECIFICATIONS SUBJECT TO CHANGE OR WITHDRAWL WITHOUT NOTICE.
3. THIS PART IS RoHS 2011/65/EU COMPLIANT.
4. FOR APPLICATIONS THAT ARE TO BE SUBJECTED TO EXTERNAL FORCE, SHOCK, OR VIBRATION, PUI AUDIO RECOMMENDS SOLID MECHANICAL REINFORCEMENT TO ENSURE RIGID COUPLING BEYOND THAT PROVIDED BY THE 3M™ VHB™ F-9473PC DOUBLE-SIDED TAPE.

UNLESS OTHERWISE SPECIFIED: DIMENSIONS ARE IN MILLIMETERS, TOLERANCES ARE ±0.5 AND ANGLES ARE ±3°.	SIZE <b>A3</b>	Designed by	Date	Checked by	Date	Approved by	Date	Drawn Date	
		M.V.	1/31/2017	M.V.	1/31/2017	B.R.	1/31/2017	1/31/2017	
ASX05408-HD-R.idw				<b>ASX05408-HD-R</b> High Definition Exciter				Edition	Sheet
								-	1 / 1