



# AIRPAX® | ATR11 Series

## Thermal Circuit Protector for Equipment

### FEATURES

- RoHS compliant, single pole, thermal current overload protector
- Reliable, trip-free operation on current overloads
- Warranty: 24-months from date of manufacture
- Protection range and operating voltage:  
0.1 to 16.0 Amps, 240 VAC, 50 VDC (cRUus,cCSAus)  
0.5 to 12 Amps, 240 VAC, 24 VDC (VDE)

### DESCRIPTION

The Airpax™ ATR11 product family is a single pole, thermally operated overload protector with a snap-acting trip mechanism that provides reliable, trip-free operation on current overloads. The ATR11 series is designed with multiple mounting configurations including central nut, wing clip, snap-in, integral and PC board mounting.

SPECIFICATIONS	
Current Ratings	0.1 to 16 amps, standard ratings available
Voltage Ratings	240 VAC, 50/60 Hz, 50 VDC, 24 VDC (VDE)
Max Breaking Capacity	8x I <sub>n</sub> for < 6A, 60A max. > 6A
Conditional Short Circuit Capacity	1KA, PC1, 240Vac 24Vdc ref: EN60934, SC: 1KA, C1 240Vac 50Vdc ref: CSA22.2 No. 235.04, UL-1077
Tripping Current Code (TC)	TC2 ref: CSA22.2, No. 234-04
Insulation Resistance	Min 100 MΩ @ 500VDC
Dielectric Strength	1,500 VAC for 1 min.
Operational Life	1000 Cycles @ 2 x I <sub>n</sub>
Overload Rating	OLO 240Vac, 50Vdc, ref: CSA22.2, No. 235-04
Overload Switching Capacity	6x I <sub>n</sub> AC Up to 9A, 4x I <sub>n</sub> DC Up to 12A 60A Max. from 10A to 12A
Max Operating Temperature	60°C (140°F) Ambient
Application Type	General Industrial ref: CSA22.2, No. 235-04
Method of Tripping	Thermal "TO", trip-free
Type of Actuation	Reset type "R"

## SHUNT TERMINAL (Option N)

Available on units of up to 6 amps equipped with a heater winding, an optional additional terminal can be provided as a parallel circuit to the main current-sensing circuit. The shunt circuit between terminals 1 and 3 may be used for any signal that may be required in addition to the main circuit. However, since the circuit makes use of the bimetal strip as a current-carrying path, the trip time of the circuit protector may be slightly influenced.

## TIME / CURRENT CHARACTERISTICS

The standard characteristic is valid for an ambient temperature of 23°C. However, if the device is to be used in an ambient temperature other than 23°C, an allowance must be made when selecting the current rating.

See the chart, graph and example below to help determine the right circuit protector rating for your application.

AMBIENT TEMPERATURE CORRECTION FACTOR									
Ambient Temperature (°C)	- 20	- 5	0	+ 10	+ 20	+ 30	+ 40	+ 50	+ 60
Multiplication Factor	0.8	0.88	0.9	0.96	1	1.05	1.12	1.2	1.3

### Example :

Normal Continuous Current = 1.8 A  
 Ambient Temperature = 40°C  
 Multiplication Factor = 1.12 (from graph)

Recommended Rating:  $1.8 \times 1.12 = 2.016$   
 Select the Nearest Rating = 2 amps

### Operating Characteristics :

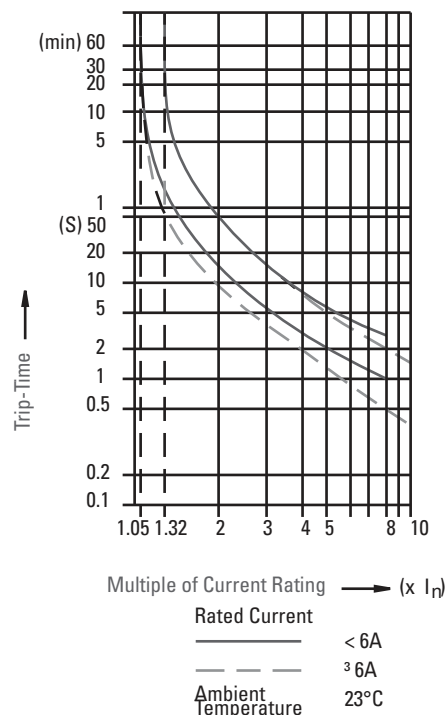

## MOUNTING OPTIONS, inches [mm]

### Central Mounting (C)

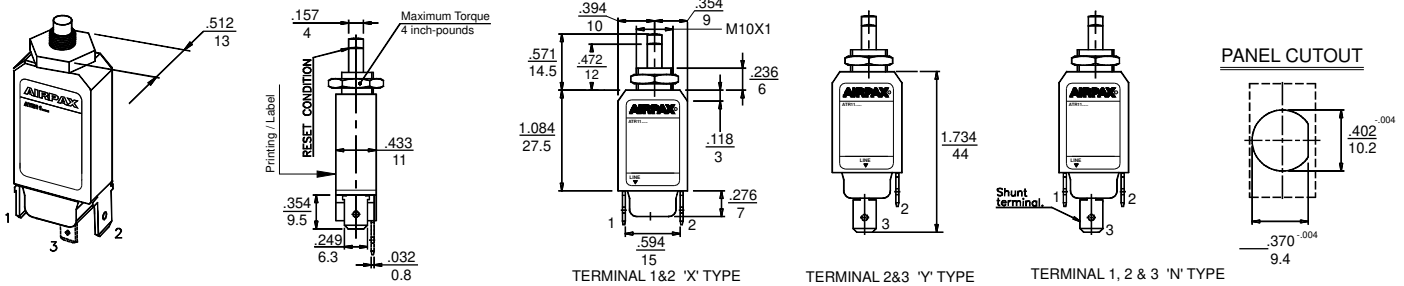

### Wing Clips (W)

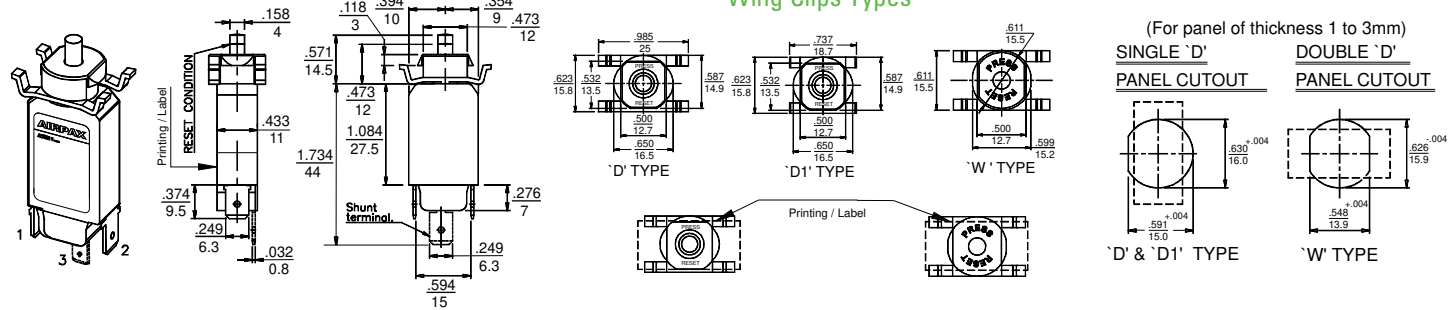

### Snap Fitting (S)

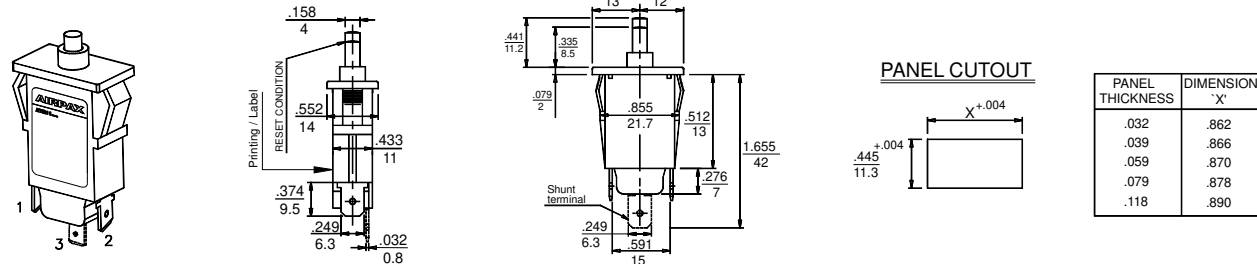

### Body Mounting (B)

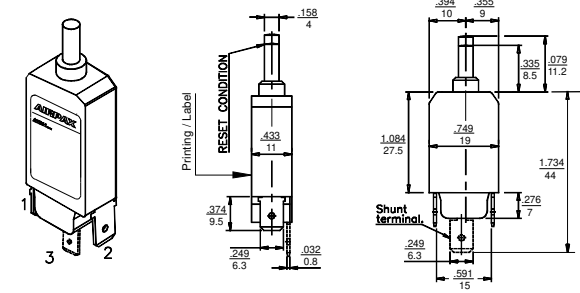

### PCB Mounting (P)

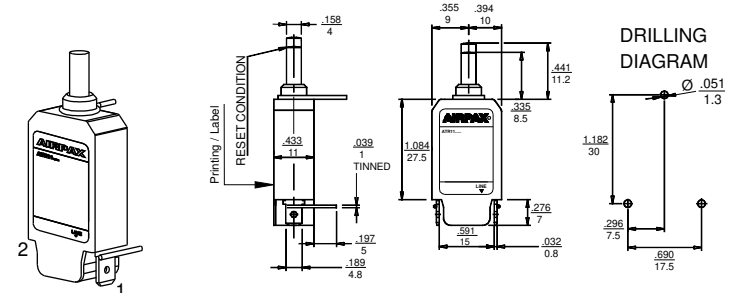

## ADDITIONAL OPTIONS

### Button Marking for Current Rating

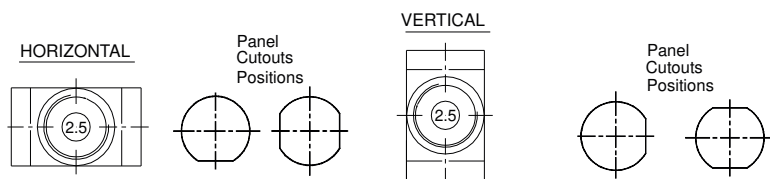

### Button Color with Trip Band

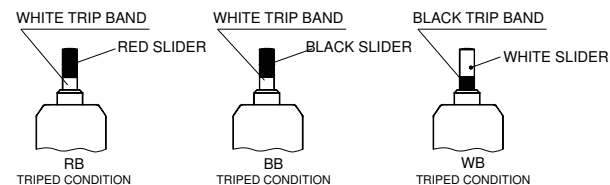

### Accessories

KNURLED NUT  
P/N 053-000-0002

SEALING KNURLED BOOT  
P/N 053-000-0001

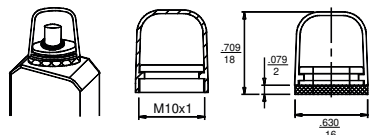
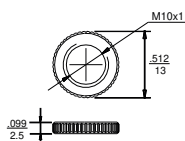

A sealing boot for central mounting Type (C) Circuit breaker to provide dust & splash protection (IP 54).

## DECISION TABLES

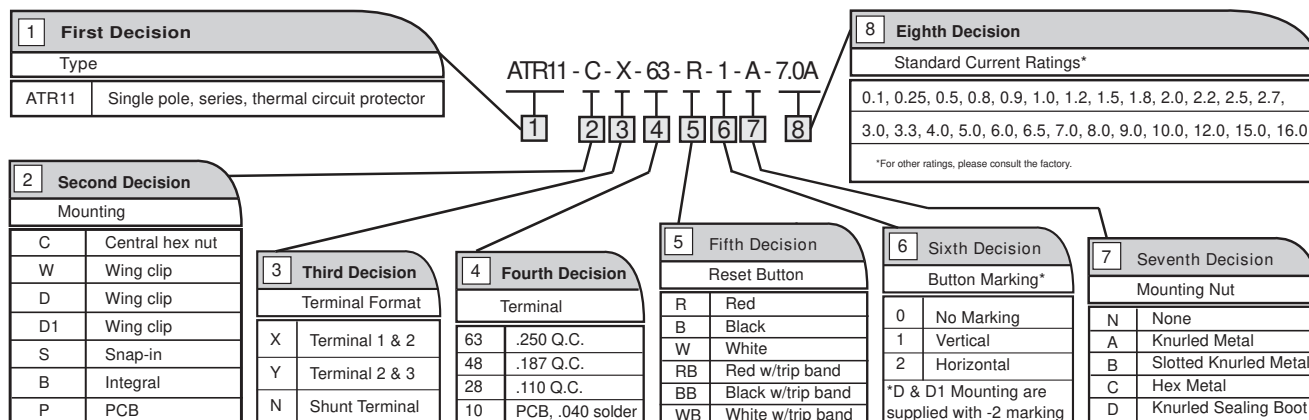

Note: Terminals 1 & 2 are standard for current ratings ≤ 12A  
 Terminals 2 & 3 are standard for current ratings > 12A  
 Terminals 1, 2 & 3 are optional for current ratings ≤ 6A