

PRODUCT NUMBER ("LF" DENOTES LEAD-FREE)	CONTACT PLATING NOTE	CONTACT DEPTH (SEE SECTION A-A)				ROHS COMPATIBILITY
		POSN 1	POSN 2	POSN 3	POSN 4	
10124620-4444P00LF	2a	LONG	LONG	LONG	LONG	SEE NOTE 8
10124620-5555P00LF	2a	SHORT	SHORT	SHORT	SHORT	SEE NOTE 8
10124620-4555P00LF	2a	LONG	SHORT	SHORT	SHORT	SEE NOTE 8
10124620-5455P00LF	2a	SHORT	LONG	SHORT	SHORT	SEE NOTE 8
10124620-5545P00LF	2a	SHORT	SHORT	LONG	SHORT	SEE NOTE 8
10124620-5554P00LF	2a	SHORT	SHORT	SHORT	LONG	SEE NOTE 8
10124620-4554P00LF	2a	LONG	SHORT	SHORT	LONG	SEE NOTE 8
10124620-5455P00	2b	SHORT	LONG	SHORT	SHORT	NA

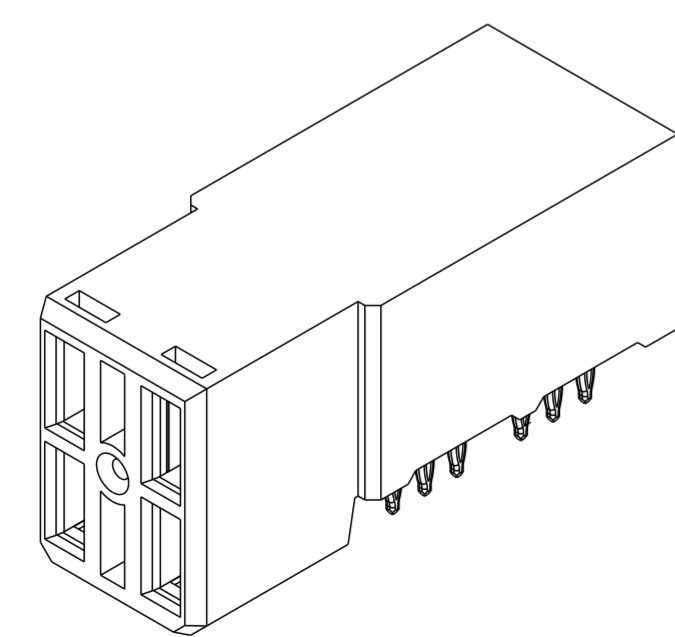

SCALE 3:1

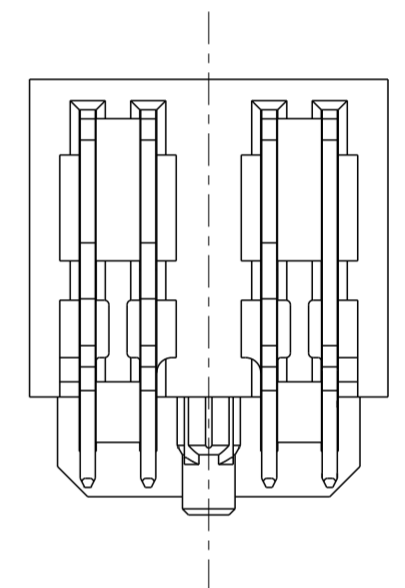
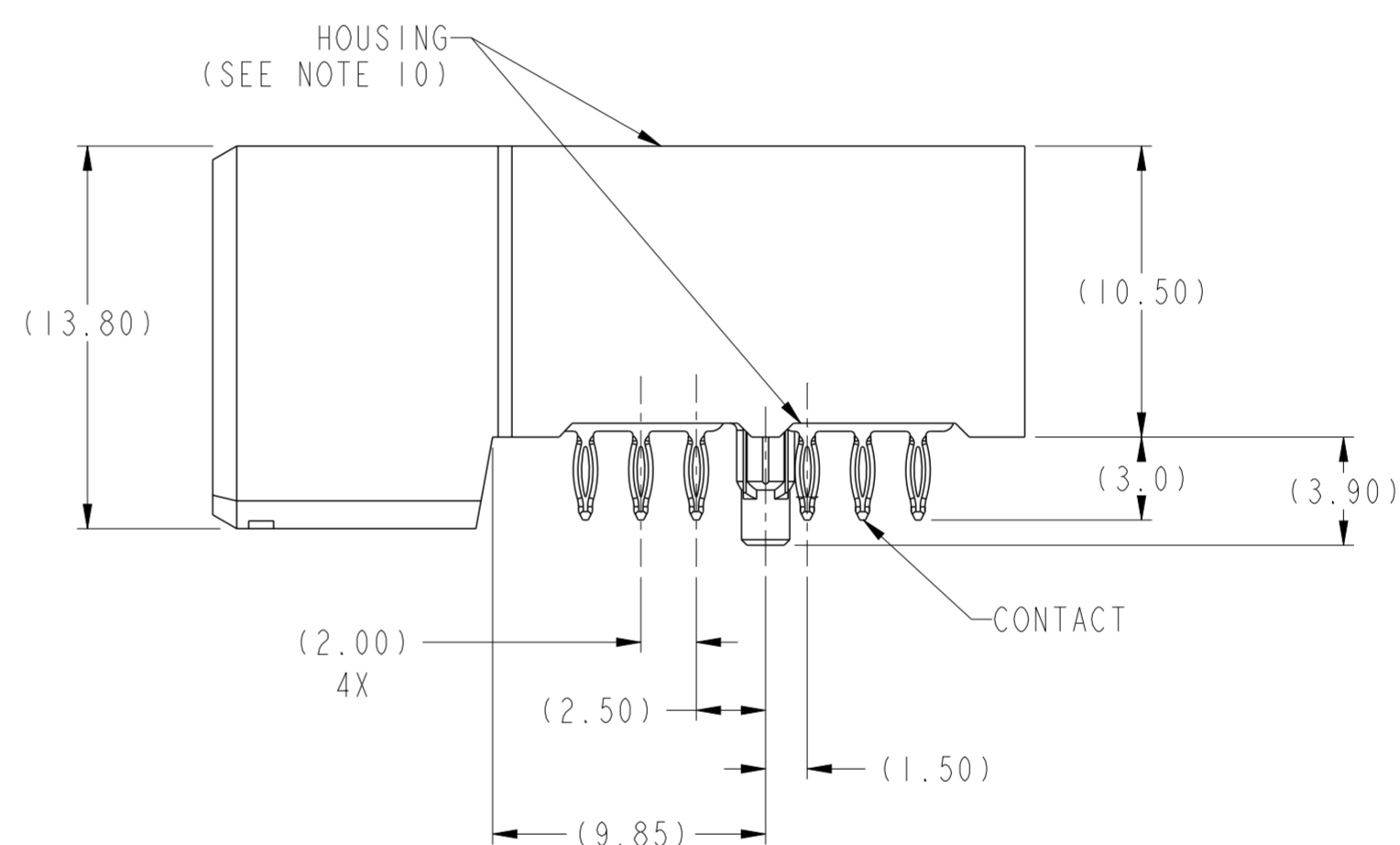
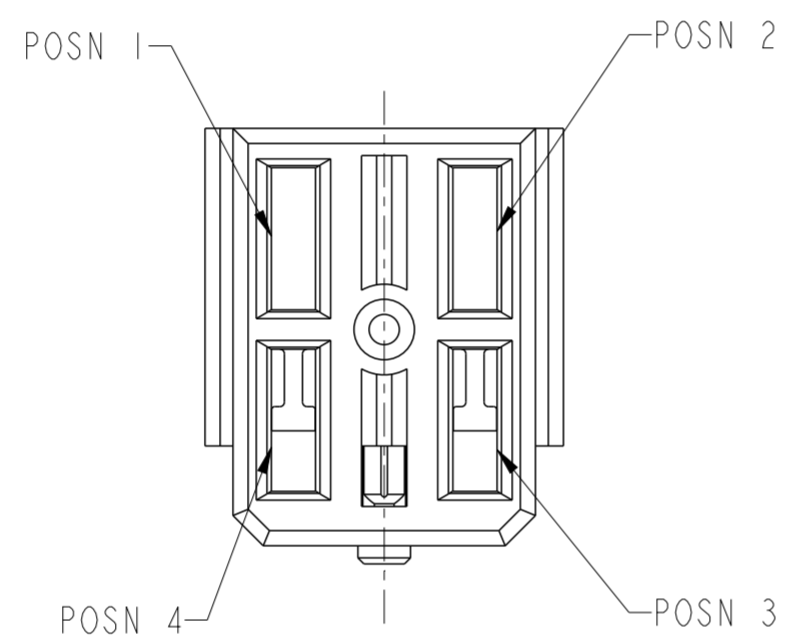
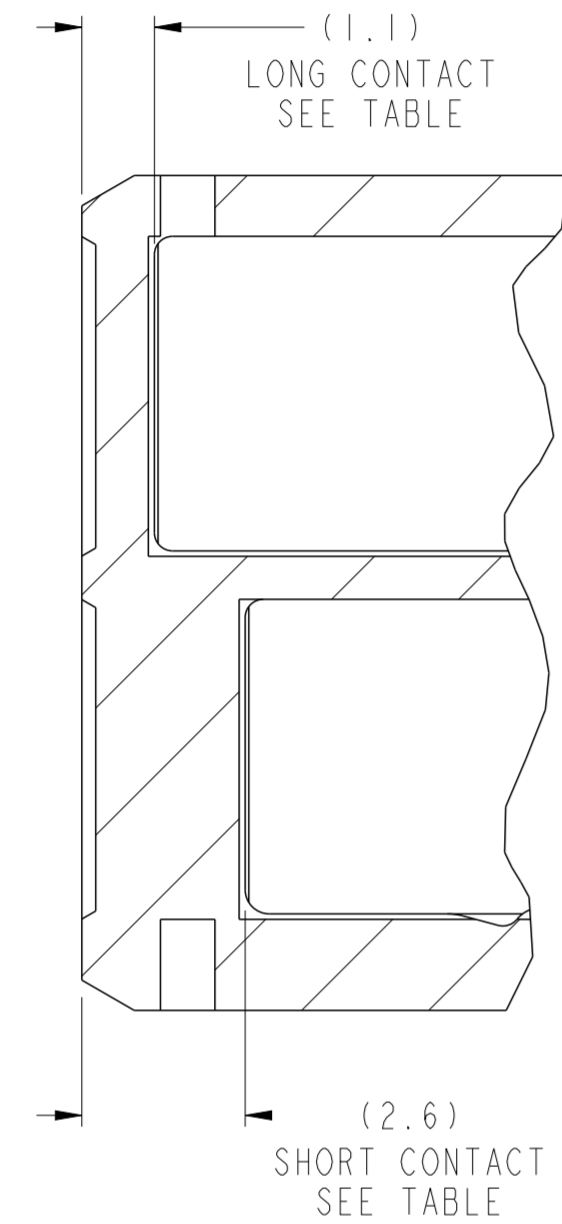
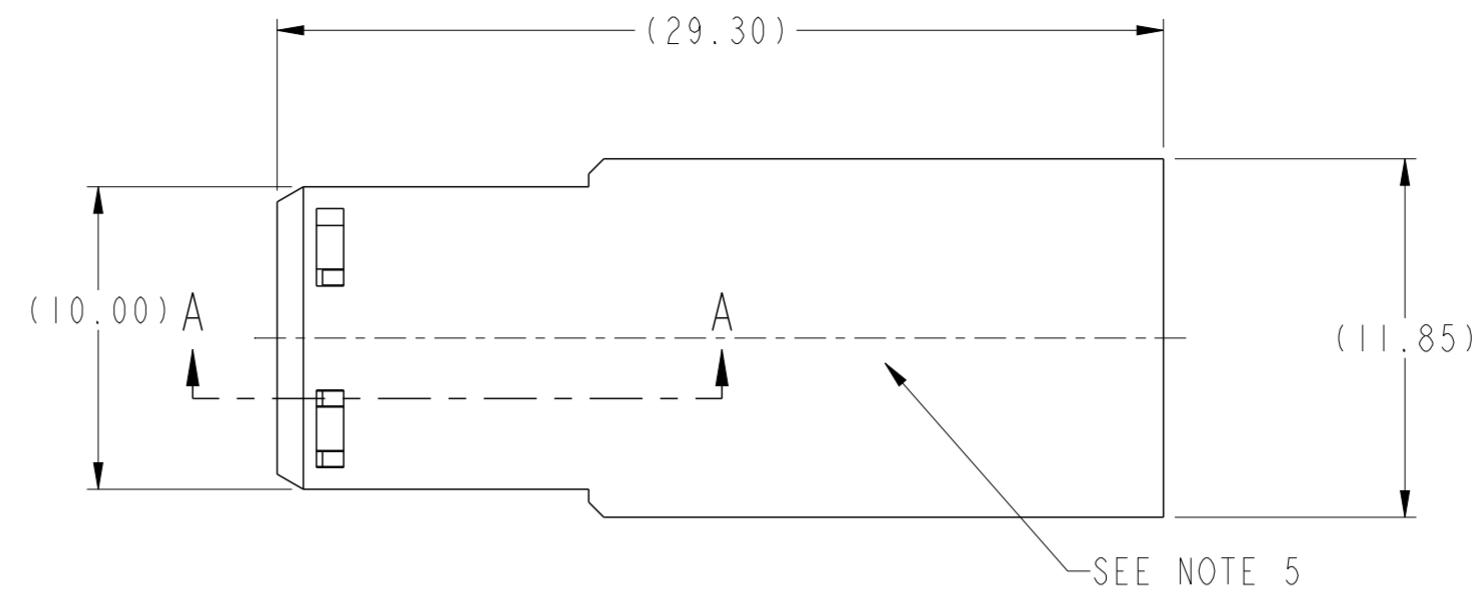
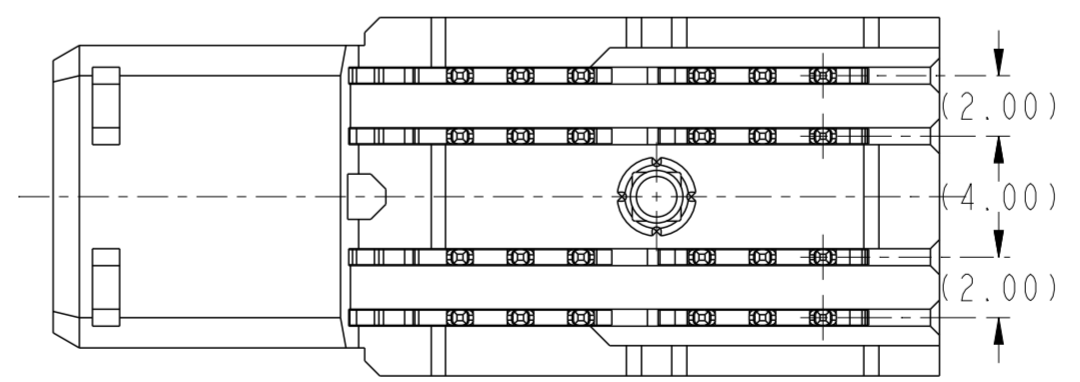

spec ref	GS-12-220	dr	Lin-Soo Ngwe	2013/03/07	projection	MM	size	A2	scale	4:1	
tolerance std	ASME Y14.5	eng	Terry Luo	2019/04/23	chr	-	ecn no	ELX-DG-33324-1	rel level	Released	
app	Heaven Cen	2019/04/25	product family	2mm High Power	cat. no.	-	Product - Customer Drw	sheet 1 of 2			
surface	-	linear	0.X	±0.3	Amphenol FCI	R/A RECEPTACLE ASSY 2X2		dwg no	10124620	rev	F
ASME Y14.5	angular	0°	±2°								

PDS: Rev :F

STATUS:Released

Printed: Apr 25, 2019

Amphenol FCI

© 2016 AFCI

TOP LAYER DESCRIPTION	TABLE 1 PLATED THROUGH-HOLE REQUIREMENTS							
	DRILLED HOLE DIAMETER	COPPER THICKNESS	TIN-LEAD THICKNESS	NICKEL THICKNESS	GOLD THICKNESS	TIN THICKNESS	SILVER THICKNESS	FINISHED HOLE DIAMETER (DIM"A")
TIN-LEAD	0.81-0.86 (0.85 DRILL)	0.025 - 0.050	0.005 - 0.015	--	--	--	--	0.65 - 0.80
IMMERSION TIN	0.81-0.86 (0.85 DRILL)	0.025 - 0.050	--	--	--	0.9 - 1.5um	--	0.70 - 0.80
IMMERSION SILVER	0.81-0.86 (0.85 DRILL)	0.025 - 0.050	--	--	--	--	0.15 - 0.65um	0.70 - 0.80
COPPER (SEE NOTE 11)	0.81-0.86 (0.85 DRILL)	0.025 - 0.050	--	--	--	--	--	0.70 - 0.80
GOLD	0.81-0.86 (0.85 DRILL)	0.025 - 0.050	--	0.003 - 0.007	FLASH UP TO 0.0002	--	--	0.69 - 0.80

NOTES:

1. CONNECTOR MATERIALS:  
HOUSING: HIGH TEMPERATURE THERMOPLASTIC, BLACK  
UL 94V-0 COMPLIANT  
CONTACT: HIGH PERFORMANCE COPPER ALLOY
2. a) CONTACT PLATING (LEAD FREE):  
PRESS-FIT TAIL MATTE TIN OVER NICKEL.  
b) CONTACT PLATING (LEADED):  
PRESS-FIT TAIL:TIN-LEAD ALLOY OVER NICKEL  
  
SEPARABLE INTERFACE:0.76 um MIN GXT OVER NICKEL
3. PRODUCT SPECIFICATION: GS-12-220
4. APPLICATION SPECIFICATION: GS-20-023
5. PRODUCT MARKING (PRODUCT NUMBER & DATE CODE) ON HOUSING IN AREA SHOWN.
6. MINIMUM NOMINAL PCB THICKNESS: 1.6mm
7. REFER TO CUSTOMER DRAWING 10035911 FOR INFORMATION REGARDING PCB LAYOUT OF POWER AND GUIDE MODULES RELATIVE TO SIGNAL MODULES.
8. PRODUCT MEETS EUROPEAN UNION DIRECTIVES AND OTHER COUNTRY REGULATIONS AS DESCRIBED IN FCI SPECIFICATION GS-22-008.
9. PACKAGING MEETS FCI SPECIFICATION GS-14-920.
10. HOUSING COMPONENT WILL WITHSTAND EXPOSURE TO 260°C PEAK TEMPERATURE FOR 60 SECONDS IN A CONVECTION, INFRA-RED, OR VAPOR PHASE REFLOW OVEN.
11. COPPER PLATING THICKNESS IN CENTER OF VIA-HOLE CAN BE NO MORE THAN 0.003 LESS THAN OTHER AREAS.

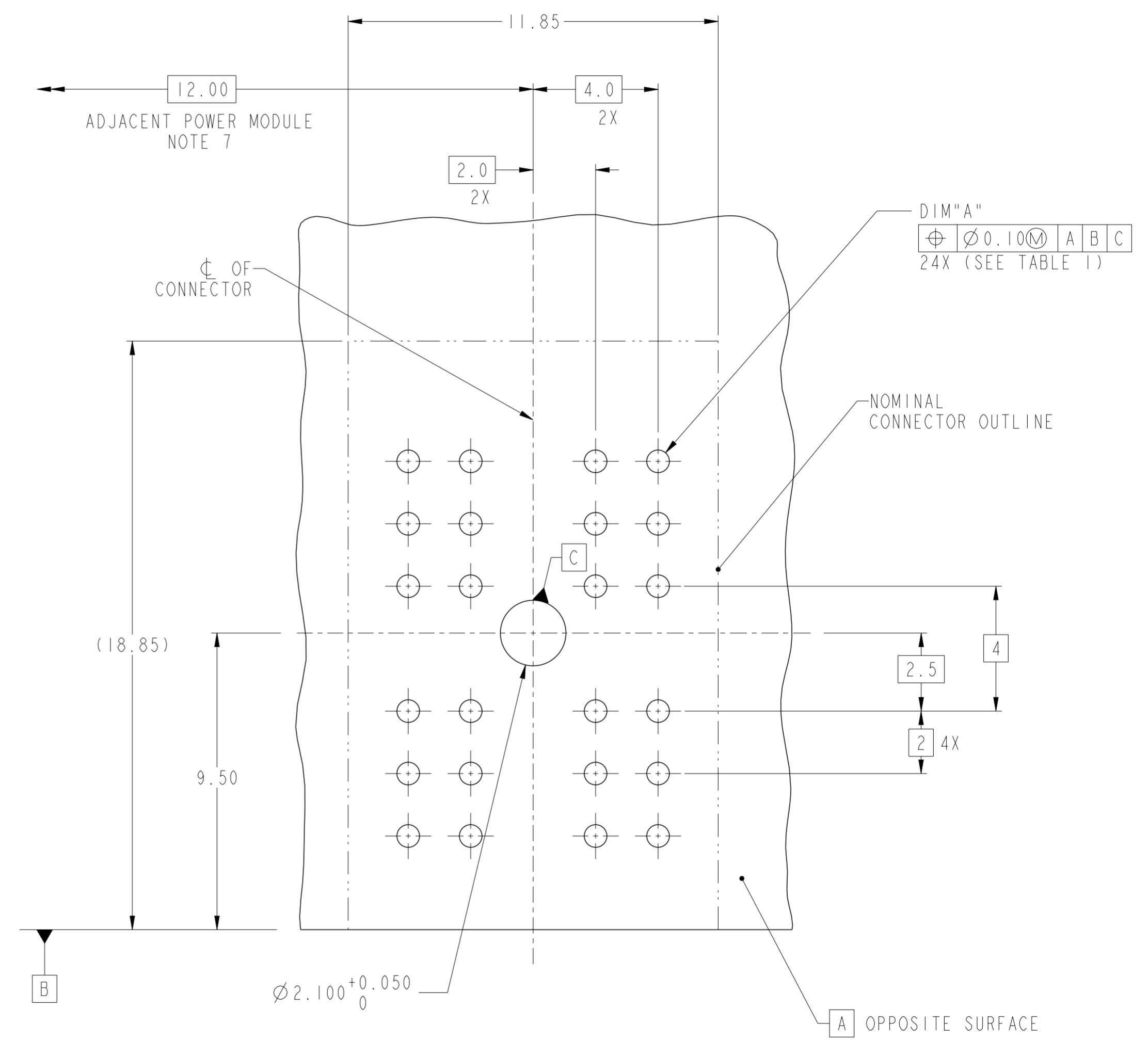

RECOMMENDED PCB LAYOUT  
COMPONENT SIDE NOTE 6 SCALE  
4:1

spec ref	GS-12-220	dr	Lin-Soe Ngwe	2013/03/07	projection	MM	size	A2	scale	1:1
tolerance std	ASME Y14.5	eng	Terry Luo	2019/04/23			ecn no	ELX-DG-33324-1		
chr	--	chr	--	rel level			Released			
appr	Heaven Cen	appr	Heaven Cen	2019/04/25			product family	2mm High Power		
surface	linear	0.X	±0.3		<b>R/A RECEPTACLE ASSY 2X2</b> AirMax Power	cat. no.	Product - Customer Drw	rel level	Released	
		0.XX	±0.10					size	A2	
		0.XXX	±0.050					scale	1:1	
ASME Y14.5	angular	0°	±2°	cat. no.		Product - Customer Drw	sheet 2 of 2			

Amphenol FCI

© 2016 AFCI