



**SERIES 265 CARD LOK**

**RECOMMENDED GAP WIDTH**

PCB + 6.35 mm (.250 in)

**RECOMMENDED TORQUE**

68 N-cm (6 in-lbs)

With "L" option 90 N-cm (8 in-lbs)

**WEIGHT**

.89 g/cm (.080 oz/in)

**MATERIALS AND FINISH**

**SHAFT**

**Material:** Alluminum alloy 7075-T6 per ASTM B221 or AMS-QQ-A-200/8

**Finish:** See finish table on opposite page

**BODIES AND WEDGES**

**Material:** Aluminum Alloy 6061-T6 per ASTM-B221 or AMS-QQ-A-200/8

**Finish:** See finish table on opposite page

**SCREW**

.09-in. or 2.5-mm hex. socket head cap screw, depending on mounting configuration

**Material:** NAS1352C, Modified NAS1352C04 or 300 series stainless steel, stainless steel per ASTM-A582

**Finish:** Passivated per AMS2700

**LOCK AND FLAT WASHER**

**Material:** 300 series stainless steel

**Finish:** Passivated per AMS2700

**ROLLPIN**

**Material:** 400 series stainless steel

**Finish:** Passivated per AMS2700

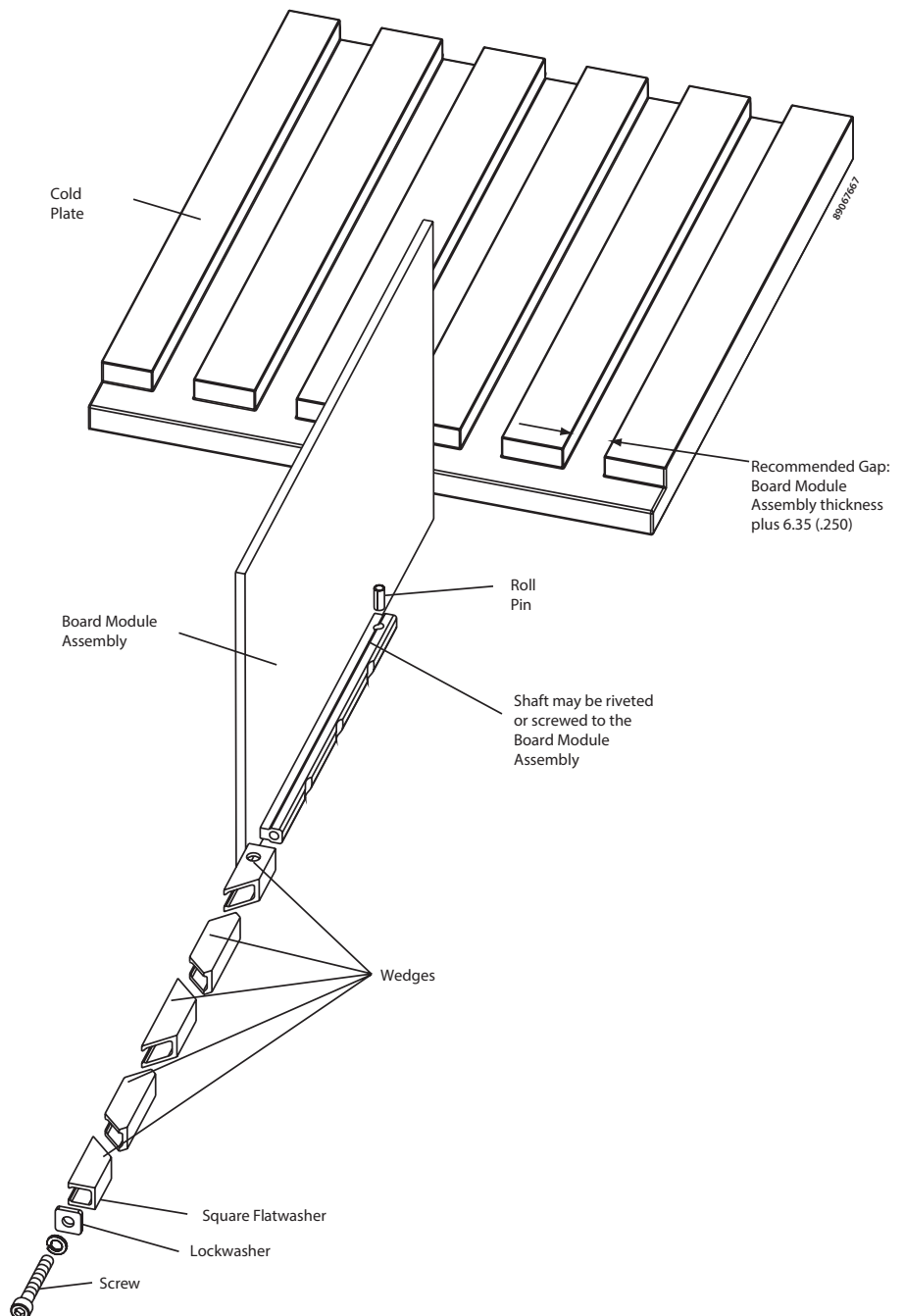

# SERIES 265 CARD LOK

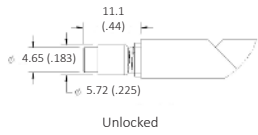

Unlocked

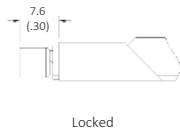

Locked

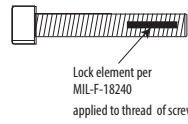

Lock element per MIL-F-18240 applied to thread of screw

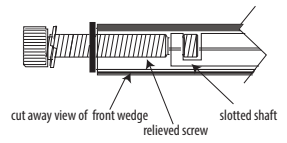

cut away view of front wedge relieved screw slotted shaft

### Detail "V"

Provides visual lock indication

### Detail "L"

Provides prevailing torque for resistance to loosening from shock and vibration. Adds 22 N-cm (2 in-lbs) torque to assembly.

### Detail "K"

Prevents the unintentional disassembly of screw from shaft.

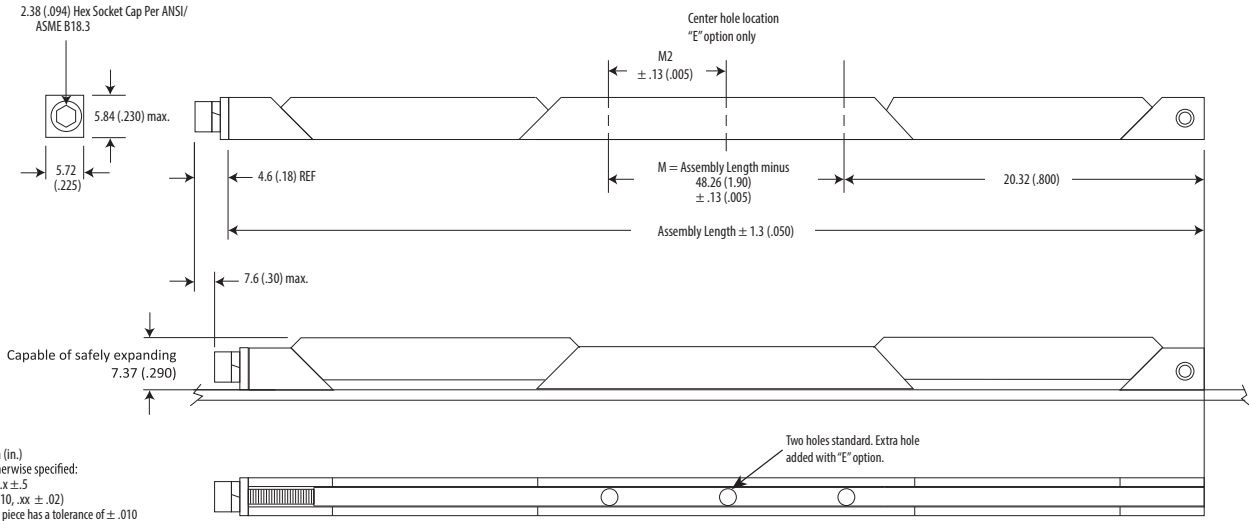

Units: mm (in.)  
Unless otherwise specified:  
.xx ± .25, .x ± .5  
(.xxx ± .010, .xx ± .02)  
Note: Each piece has a tolerance of ± .010

Part Number Code	M	V	A	265	-	2.80	E	H	L	K
<b>Screw</b>										
Metric Screw Head M2.5 Hex Drive	M									
Standard Screw Head 3/32 Hex Drive	[Blank]									
<b>Type</b>										
Torque Limiting version*	TLC									
Standard version with Visual Indicator	V									
Standard version	[Blank]									
<b>Finish</b>										
BlackAnodized	A									
Or choose from Finish Table										
<b>Length</b>										
Length in 12.7 (.50) increments						71.12 [2.80]				
						to 325.12 [12.80]				
<b>Mounting</b>										
Additional Center Mounting Hole							E			
None							[Blank]			
Mounting Options - through mounting holes								H		
Or choose from Mounting Method Table										
<b>Lock Patch</b>										
Lock Patch									L	
None									[Blank]	
Captive Screw										K
None										[Blank]

### Part Number Code Example: TLCHA265-4.80H

Series 265 Card-Lok, with torque limiting option, hard black anodized finish, 121.9 (4.80) long and standard rivet hole mounting

### FINISH TABLE

CODE LETTER	SURFACE FINISH
[blank]	CHEM FILM PER MIL-DTL-5541 CLASS 3, GOLD, TYPE I
R	CHEM FILM PER MIL-DTL-5541 CLASS 3, CLEAR, TYPE II
A	BLACK ANODIZE PER MIL-A-8625 TYPE II, CLASS 2
HA	HARD BLACK ANODIZE PER MIL-A-8625 TYPE III, CLASS 2
EN	ELECTROLESS NICKEL PER MIL-C-26074 CLASS 4, GRADE B, BRIGHT

### MOUNTING METHOD TABLE

CODE LETTER	METHOD
H	Ø1.73/1.85 (.068/.073) DIA. THROUGH HOLES COUNTERSINK 100° x 1.52 (.060) DEEP
T0	0-80 TAPPED HOLE
T2	2-56 TAPPED HOLE
TM2	M2 x 0.40 TAPPED HOLE
TM2.5	M2.5 x 0.45 TAPPED HOLE

\*NOTE: FOR THE TORQUE LIMITING "TLC" VERSION:  
THE MINIMUM LENGTH IS 96.52 (3.80)  
THE FRONT MOUNTING HOLE, NEAREST TO THE SCREW,  
WILL BE REPLACED WITH AN INDEXING PIN  
VISUAL INDICATOR OPTION NOT AVAILABLE  
MUST CLICK 3+ TIMES FOR PROPER INSTALLATION



**SCHROFF**

nVent may modify standard parts without prior notice to or approval from customers. These modifications may change product appearance, but will not have a detrimental effect on form, fit or function. ©2018 nVent. All nVent marks and logos are owned or licensed by nVent Services GmbH or its affiliates. All other trademarks are the property of their respective owners. nVent reserves the right to change specifications without notice.