



# STGP12NB60KD - STGB12NB60KD

N-CHANNEL 18A - 600V TO-220/D<sup>2</sup>PAK  
SHORT CIRCUIT PROOF PowerMESH™ IGBT

TYPE	V <sub>CES</sub>	V <sub>CE(sat)</sub> (Max) @25°C	I <sub>C</sub> (#) @ 100°C
STGP12NB60KD	600 V	< 2.8 V	18 A
STGB12NB60KD	600 V	< 2.8 V	18 A

- HIGH INPUT IMPEDANCE
- LOW ON-LOSSES
- LOW GATE CHARGE
- HIGH CURRENT CAPABILITY
- OFF LOSSES INCLUDE TAIL CURRENT
- VERY HIGH FREQUENCY OPERATION
- TYPICAL SHORT CIRCUIT WITHSTAND TIME 10 MICROS
- CO-PACKAGED ANTIPARALLEL DIODE

## DESCRIPTION

Using the latest high voltage technology based on a patented strip layout, STMicroelectronics has designed an advanced family of IGBTs, the PowerMESH™ IGBTs, with outstanding performances. The suffix "K" identifies a family optimized for high frequency applications (up to 50kHz) and short circuit proof in order to achieve very high switching performances (reduced t<sub>fall</sub>) maintaining a low voltage drop.

## APPLICATIONS

- HIGH FREQUENCY MOTOR CONTROLS
- SMPS
- UPS

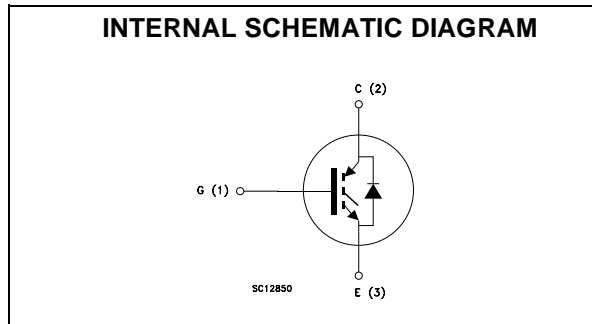
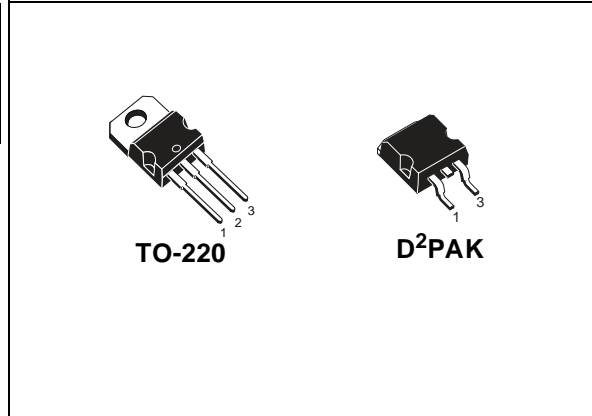

## ORDERING INFORMATION

SALES TYPE	MARKING	PACKAGE	PACKAGING
STGP12NB60KD	GP12NB60KD	TO-220	TUBE
STGB12NB60KDT4	GB12NB60KD	D <sup>2</sup> PAK	TAPE & REEL

## STGP12NB60KD - STGB12NB60KD

### ABSOLUTE MAXIMUM RATINGS

Symbol	Parameter	Value	Unit
$V_{CES}$	Collector-Emitter Voltage ( $V_{GS} = 0$ )	600	V
$V_{ECR}$	Emitter-Collector Voltage	20	V
$V_{GE}$	Gate-Emitter Voltage	$\pm 20$	V
$I_C$	Collector Current (continuous) at $T_C = 25^\circ\text{C}$ (#)	30	A
$I_C$	Collector Current (continuous) at $T_C = 100^\circ\text{C}$ (#)	18	A
$I_{CM}(\bullet)$	Collector Current (pulsed)	60	A
$T_{sc}$	Short Circuit Withstand	10	$\mu\text{s}$
$P_{TOT}$	Total Dissipation at $T_C = 25^\circ\text{C}$	125	W
	Derating Factor	1.0	W/ $^\circ\text{C}$
$T_{stg}$	Storage Temperature	-65 to 150	$^\circ\text{C}$
$T_j$	Max. Operating Junction Temperature	150	$^\circ\text{C}$

(•) Pulse width limited by safe operating area

### THERMAL DATA

Rthj-case	Thermal Resistance Junction-case Max	1.0	$^\circ\text{C}/\text{W}$
Rthj-amb	Thermal Resistance Junction-ambient Max	62.5	$^\circ\text{C}/\text{W}$

### ELECTRICAL CHARACTERISTICS ( $T_{CASE} = 25^\circ\text{C}$ UNLESS OTHERWISE SPECIFIED)

OFF

Symbol	Parameter	Test Conditions	Min.	Typ.	Max.	Unit
$V_{BR}(CES)$	Collector-Emitter Breakdown Voltage	$I_C = 250 \mu\text{A}$ , $V_{GE} = 0$	600			V
$I_{CES}$	Collector cut-off ( $V_{GE} = 0$ )	$V_{CE} = \text{Max Rating}$ , $T_C = 25^\circ\text{C}$ $V_{CE} = \text{Max Rating}$ , $T_C = 125^\circ\text{C}$			50 100	$\mu\text{A}$ $\mu\text{A}$
$I_{GES}$	Gate-Emitter Leakage Current ( $V_{CE} = 0$ )	$V_{GE} = \pm 20\text{V}$ , $V_{CE} = 0$			$\pm 100$	nA

ON (1)

Symbol	Parameter	Test Conditions	Min.	Typ.	Max.	Unit
$V_{GE(th)}$	Gate Threshold Voltage	$V_{CE} = V_{GE}$ , $I_C = 250 \mu\text{A}$	5		7	V
$V_{CE(sat)}$	Collector-Emitter Saturation Voltage	$V_{GE} = 15\text{V}$ , $I_C = 12\text{A}$ $V_{GE} = 15\text{V}$ , $I_C = 12\text{A}$ , $T_j = 125^\circ\text{C}$		2.2 1.7	2.8	V V

DYNAMIC

Symbol	Parameter	Test Conditions	Min.	Typ.	Max.	Unit
$g_{fs}$	Forward Transconductance	$V_{CE} = 25\text{V}$ , $I_C = 12\text{A}$		5		S
$C_{ies}$ $C_{oes}$ $C_{res}$	Input Capacitance Output Capacitance Reverse Transfer Capacitance	$V_{CE} = 25\text{V}$ , $f = 1\text{MHz}$ , $V_{GE} = 0$		890 110 22		pF pF pF
$Q_g$ $Q_{ge}$ $Q_{gc}$	Total Gate Charge Gate-Emitter Charge Gate-Collector Charge	$V_{CE} = 480\text{V}$ , $I_C = 12\text{A}$ , $V_{GE} = 15\text{V}$		54 8 31		nC nC nC
$I_{CL}$	Latching Current	$V_{clamp} = 480\text{V}$ , $V_{GE} = 15\text{V}$ , $T_j = 125^\circ\text{C}$ , $R_G = 10\ \Omega$		48		A
$T_{wsc}$	Short Circuit WITHSTAND Time	$V_{CE} = 0.5 BV_{ces}$ , $V_{GE} = 15\text{V}$ $T_j = 125^\circ\text{C}$ , $R_G = 10\ \Omega$	10			$\mu\text{s}$

**ELECTRICAL CHARACTERISTICS (CONTINUED)**

**SWITCHING ON**

Symbol	Parameter	Test Conditions	Min.	Typ.	Max.	Unit
t <sub>d(on)</sub>	Turn-on Delay Time	V <sub>CC</sub> = 480 V, I <sub>C</sub> = 12 A		25		ns
t <sub>r</sub>	Rise Time	R <sub>G</sub> = 10Ω , V <sub>GE</sub> = 15 V		14.5		ns
(di/dt) <sub>on</sub>	Turn-on Current Slope	V <sub>CC</sub> = 480 V, I <sub>C</sub> = 12 A R <sub>G</sub> =10Ω		590		A/μs
E <sub>on</sub>	Turn-on Switching Losses	V <sub>GE</sub> = 15 V, T <sub>j</sub> = 125°C		180		μJ

**SWITCHING OFF**

Symbol	Parameter	Test Conditions	Min.	Typ.	Max.	Unit
t <sub>c</sub>	Cross-over Time	V <sub>CC</sub> = 480 V, I <sub>C</sub> = 12 A, R <sub>GE</sub> = 10 Ω , V <sub>GE</sub> = 15 V		130		ns
t <sub>r(Voff)</sub>	Off Voltage Rise Time			25		ns
t <sub>d(off)</sub>	Delay Time			96		ns
t <sub>f</sub>	Fall Time			100		ns
E <sub>off(**)</sub>	Turn-off Switching Loss			258		μJ
E <sub>ts</sub>	Total Switching Loss			410		μJ
t <sub>c</sub>	Cross-over Time	V <sub>CC</sub> = 480 V, I <sub>C</sub> = 12 A, R <sub>GE</sub> = 10 Ω , V <sub>GE</sub> = 15 V T <sub>j</sub> = 125 °C		310		ns
t <sub>r(Voff)</sub>	Off Voltage Rise Time			80		ns
t <sub>d(off)</sub>	Delay Time			150		ns
t <sub>f</sub>	Fall Time			220		ns
E <sub>off(**)</sub>	Turn-off Switching Loss			650		μJ
E <sub>ts</sub>	Total Switching Loss			830		μJ

Note: 1. Pulsed: Pulse duration = 300 μs, duty cycle 1.5 %.  
 2. Pulse width limited by max. junction temperature.  
 (\*\*)Losses include Also the Tail (Jedec Standardization)

**COLLECTOR-EMITTER DIODE**

Symbol	Parameter	Test Conditions	Min.	Typ.	Max.	Unit
I <sub>f</sub>	Forward Current				12	A
I <sub>fm</sub>	Forward Current pulsed				48	A
V <sub>f</sub>	Forward On-Voltage	I <sub>f</sub> = 6 A I <sub>f</sub> = 6 A, T <sub>j</sub> = 125 °C		1.3 1.1	1.9	V V
t <sub>rr</sub>	Reverse Recovery Time	I <sub>f</sub> = 6 A , V <sub>R</sub> = 50 V, T <sub>j</sub> = 125°C, di/dt = 100 A/μs		80		ns
Q <sub>rr</sub>	Reverse Recovery Charge			240		nC
I <sub>rrm</sub>	Reverse Recovery Current			5.5		A

(#) Calculated according to the iterative formula:

$$I_C(T_C) = \frac{T_{JMAX} - T_C}{R_{THJ-C} \times V_{CESAT(MAX)}(T_C, I_C)}$$

# STGP12NB60KD - STGB12NB60KD

**Output Characteristics**

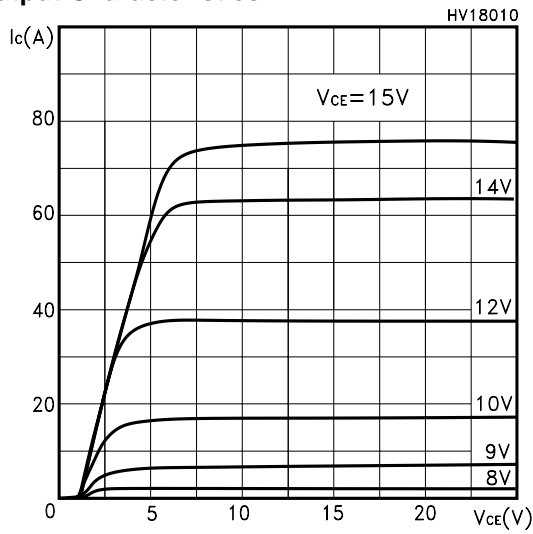

**Transfer Characteristics**

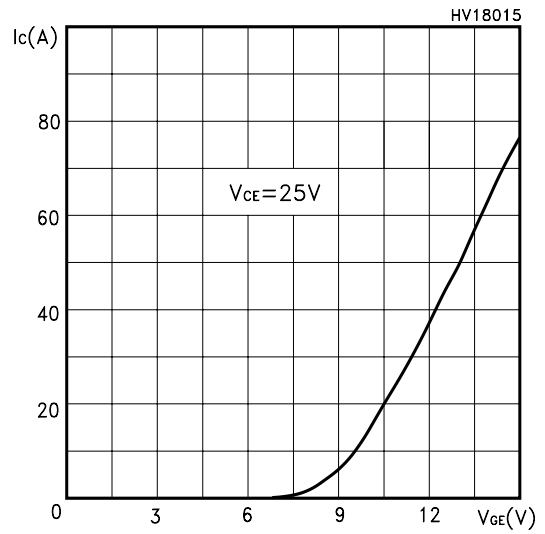

**Transconductance**

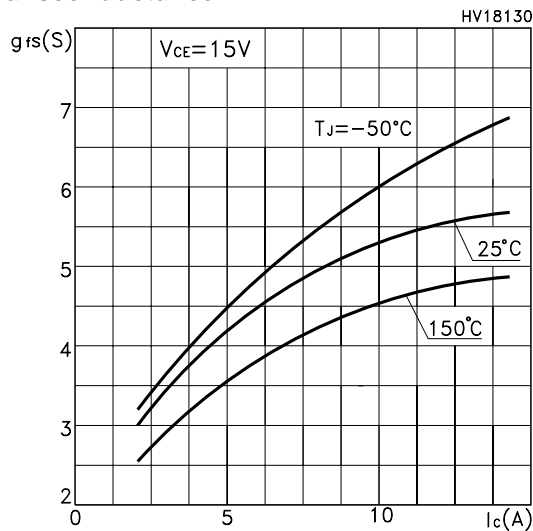

**Normalized Collector-Emitter On Voltage vs Temp.**

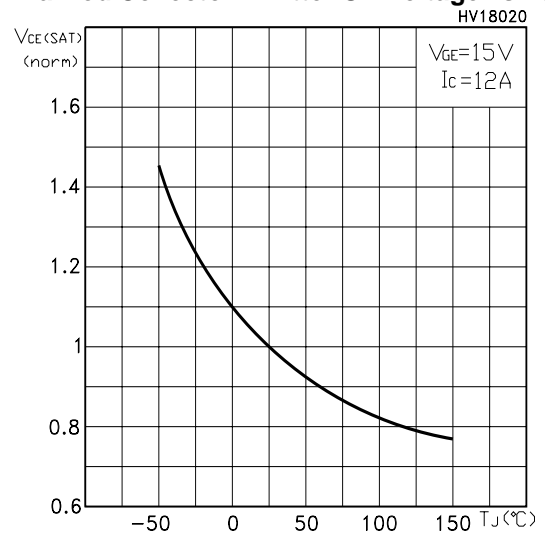

**Collector-Emitter On Voltage vs Temperature**

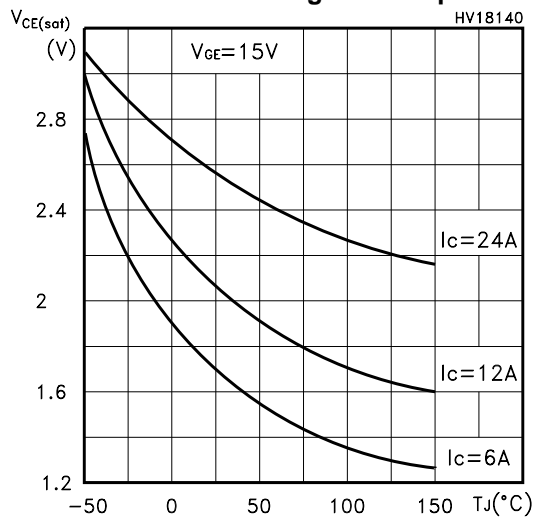

**Collector-Emitter On Voltage vs Collector Current**

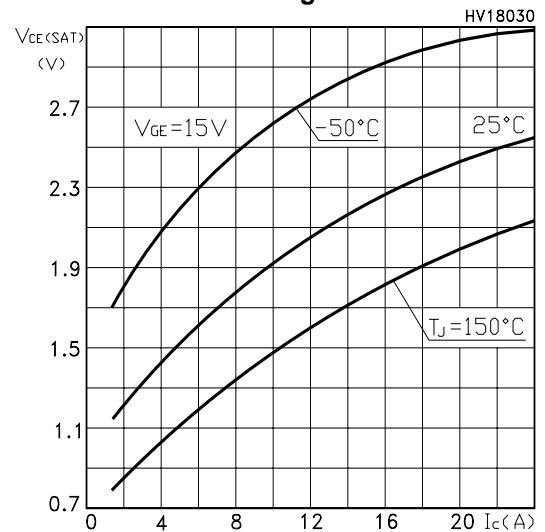

Gate Threshold vs Temperature

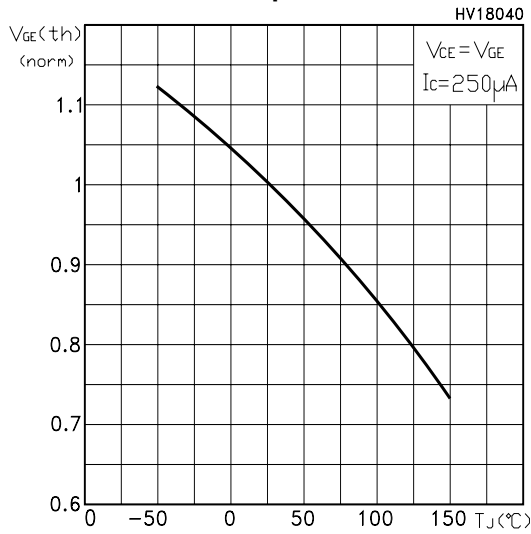

Normalized Breakdown Voltage vs Temperature

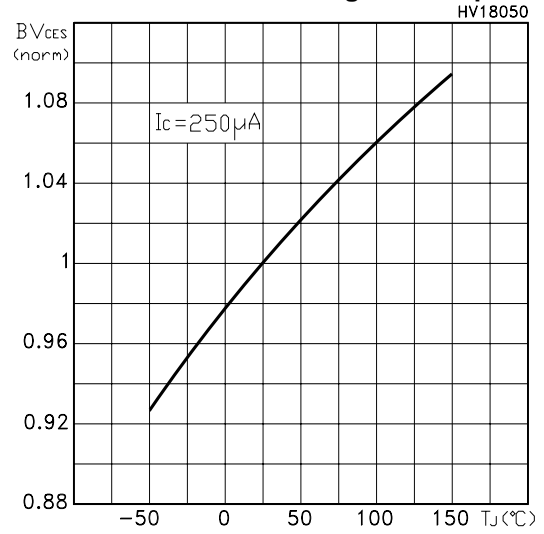

Capacitance Variations

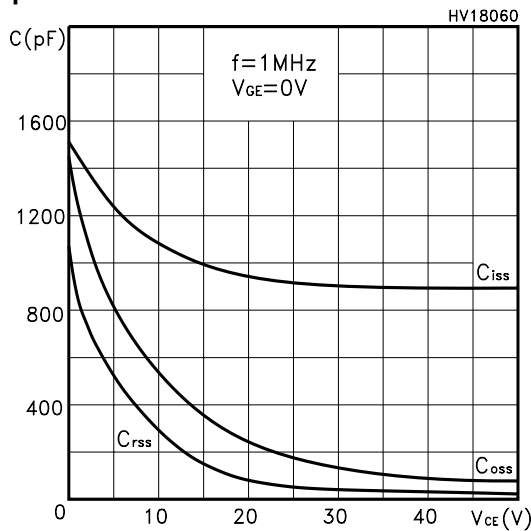

Gate Charge vs Gate-Emitter Voltage

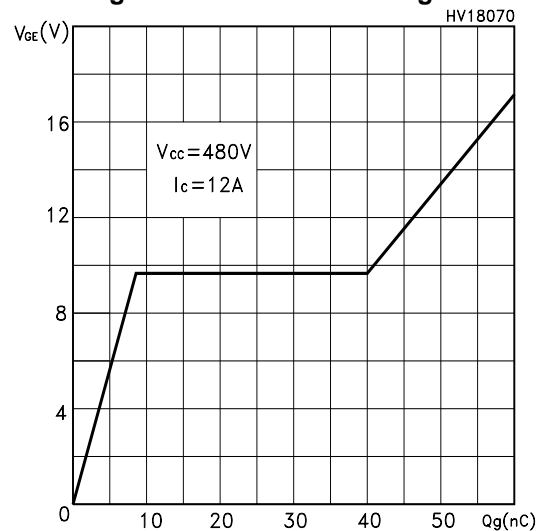

Total Switching Losses vs Gate Resistance

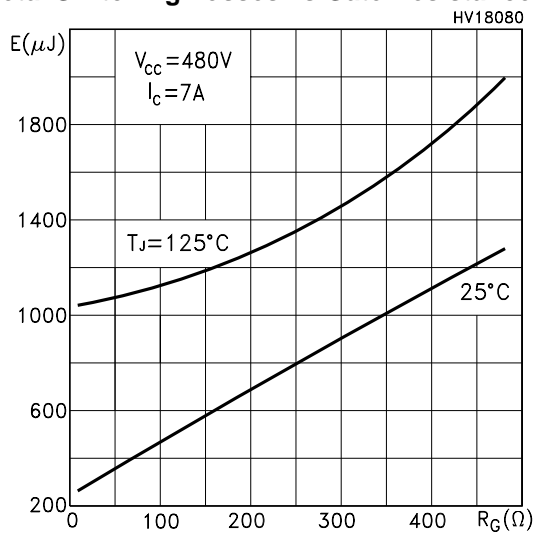

Total Switching Losses vs Temperature

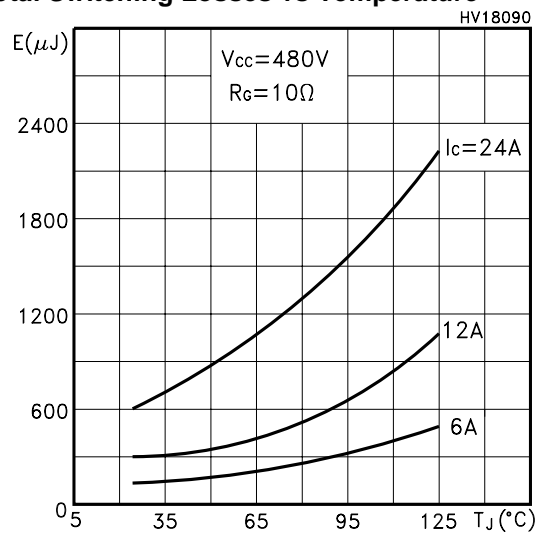

# STGP12NB60KD - STGB12NB60KD

## Total Switching Losses vs Collector Current

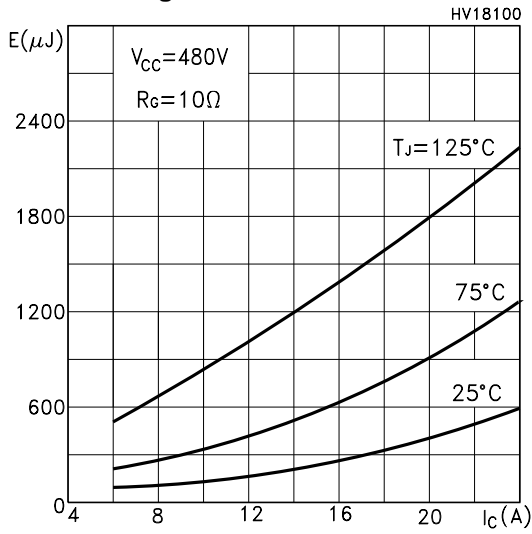

## Diode Forward Voltage

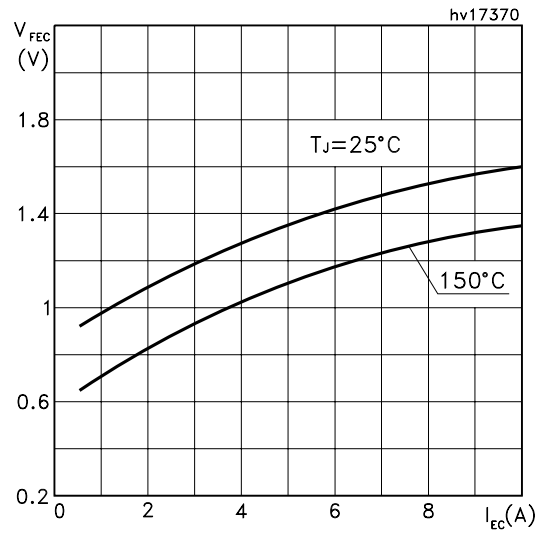

## Turn-Off SOA

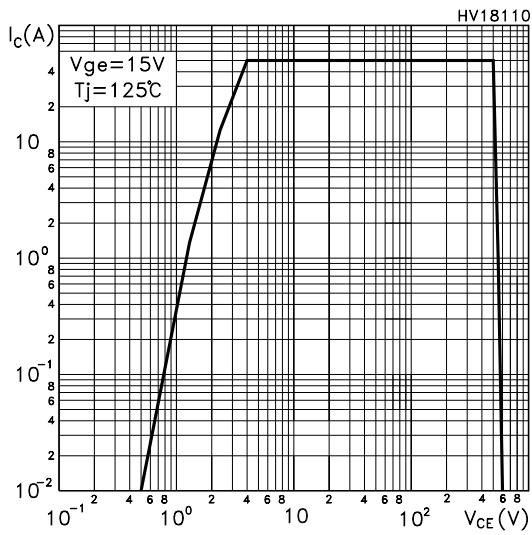

## Thermal Impedance

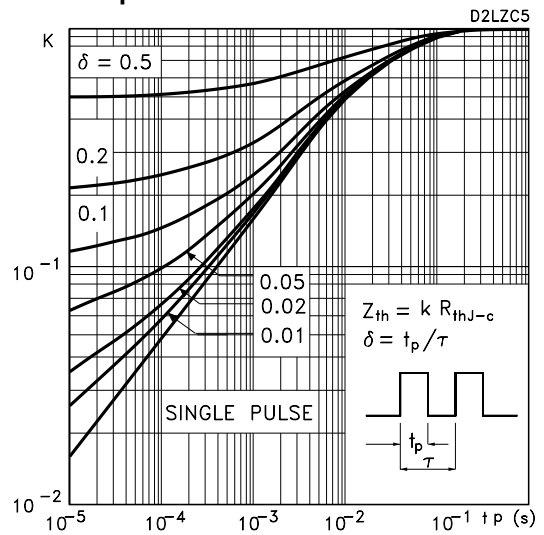

Fig. 1: Gate Charge test Circuit

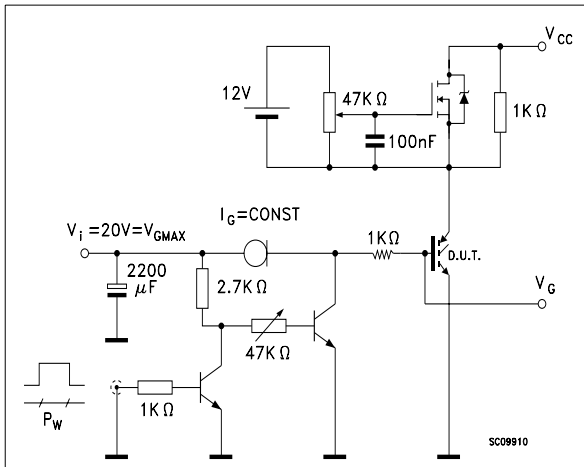
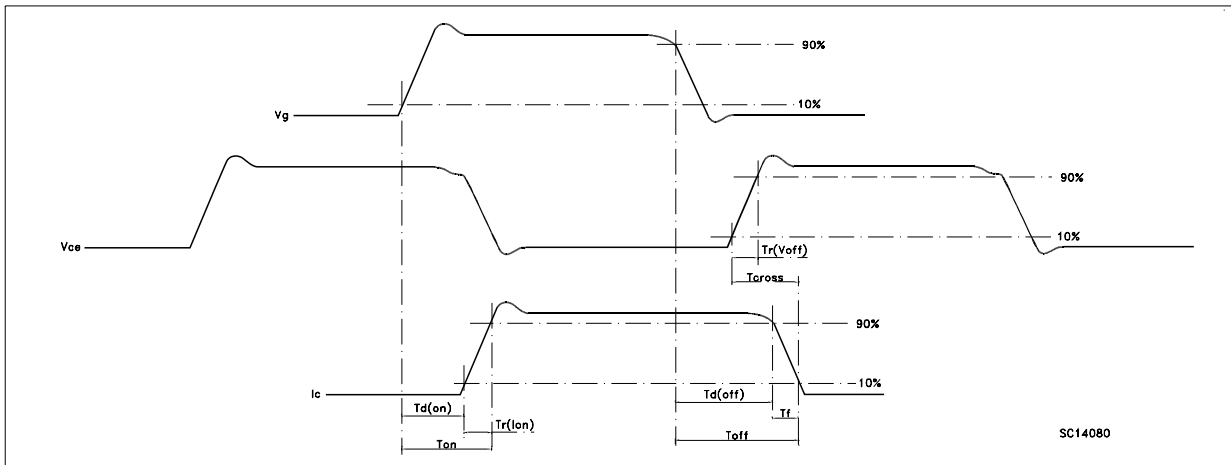
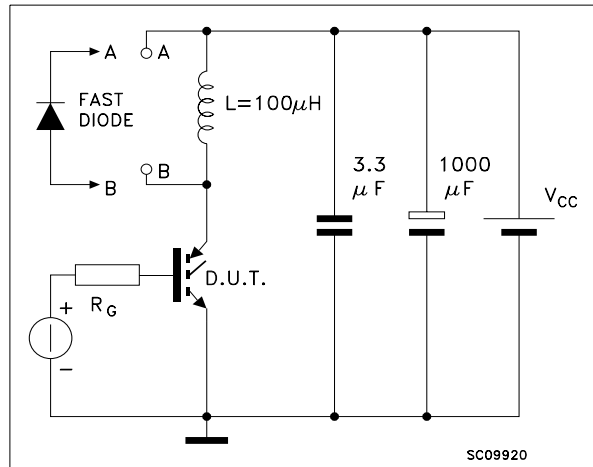
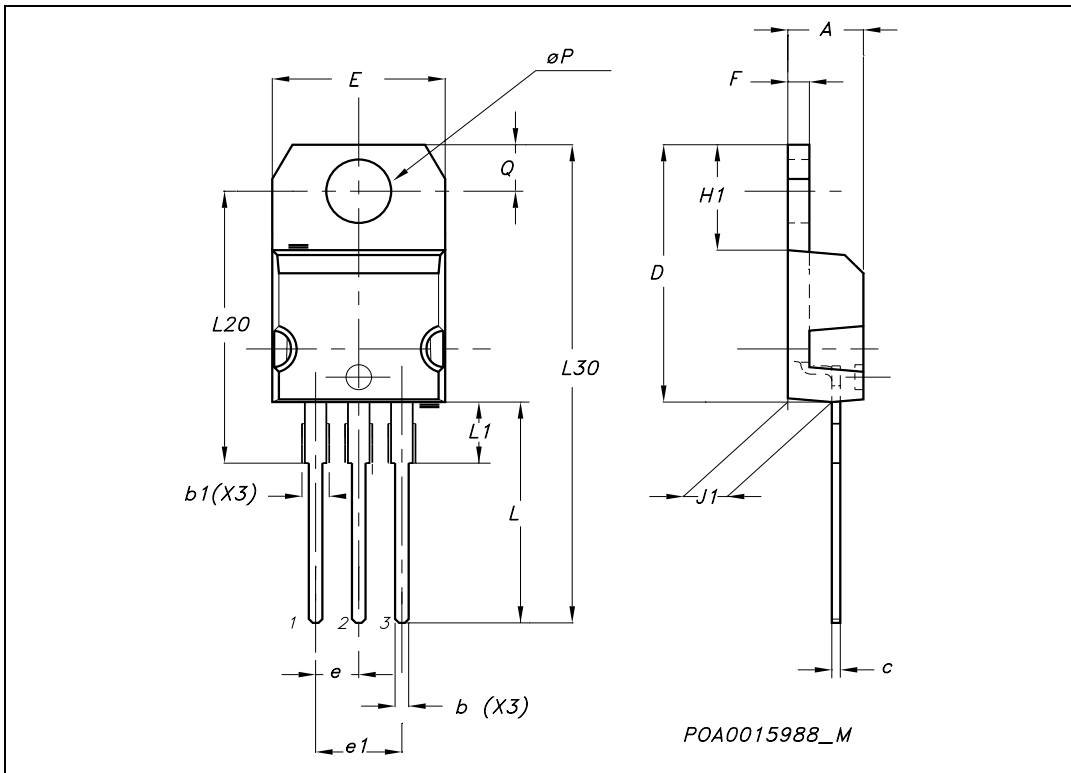

Fig. 2: Test Circuit For Inductive Load Switching



**TO-220 MECHANICAL DATA**

DIM.	mm.			inch		
	MIN.	TYP	MAX.	MIN.	TYP.	MAX.
A	4.40		4.60	0.173		0.181
b	0.61		0.88	0.024		0.034
b1	1.15		1.70	0.045		0.066
c	0.49		0.70	0.019		0.027
D	15.25		15.75	0.60		0.620
E	10		10.40	0.393		0.409
e	2.40		2.70	0.094		0.106
e1	4.95		5.15	0.194		0.202
F	1.23		1.32	0.048		0.052
H1	6.20		6.60	0.244		0.256
J1	2.40		2.72	0.094		0.107
L	13		14	0.511		0.551
L1	3.50		3.93	0.137		0.154
L20		16.40			0.645	
L30		28.90			1.137	
øP	3.75		3.85	0.147		0.151
Q	2.65		2.95	0.104		0.116





**D<sup>2</sup>PAK MECHANICAL DATA**

DIM.	mm.			inch		
	MIN.	TYP	MAX.	MIN.	TYP.	MAX.
A	4.4		4.6	0.173		0.181
A1	2.49		2.69	0.098		0.106
A2	0.03		0.23	0.001		0.009
B	0.7		0.93	0.027		0.036
B2	1.14		1.7	0.044		0.067
C	0.45		0.6	0.017		0.023
C2	1.23		1.36	0.048		0.053
D	8.95		9.35	0.352		0.368
D1		8			0.315	
E	10		10.4	0.393		
E1		8.5			0.334	
G	4.88		5.28	0.192		0.208
L	15		15.85	0.590		0.625
L2	1.27		1.4	0.050		0.055
L3	1.4		1.75	0.055		0.068
M	2.4		3.2	0.094		0.126
R		0.4			0.015	
V2	0°		8°			

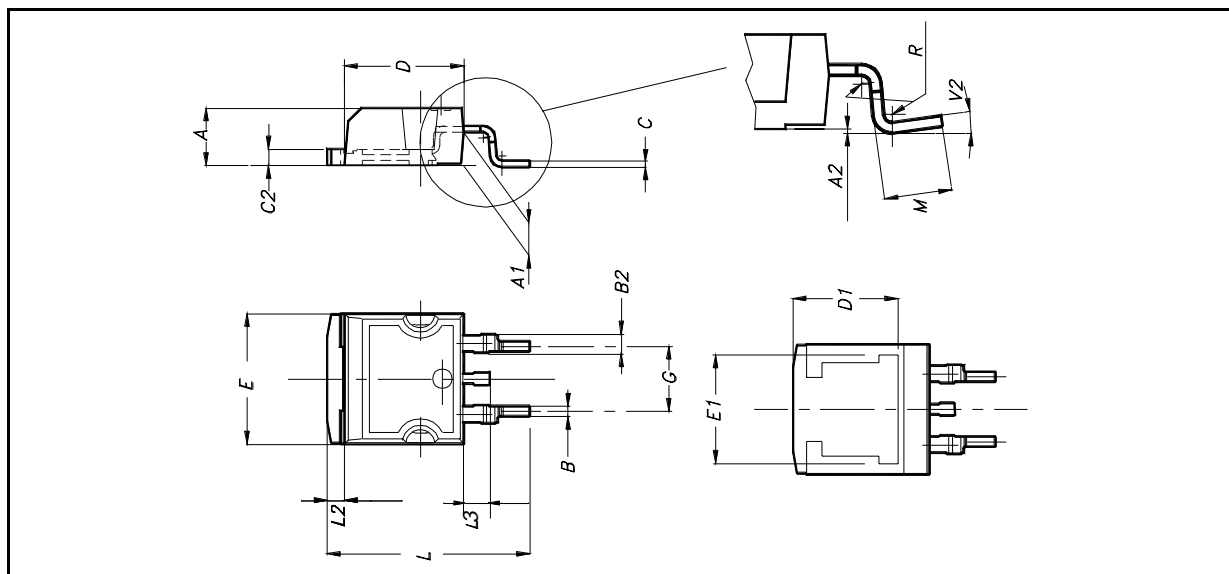

**D<sup>2</sup>PAK FOOTPRINT**

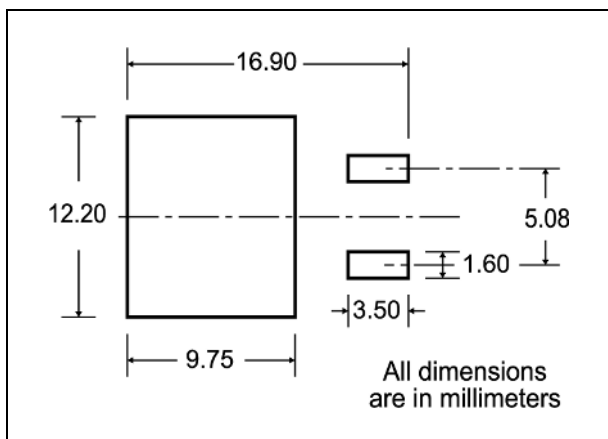

**TUBE SHIPMENT (no suffix)\***

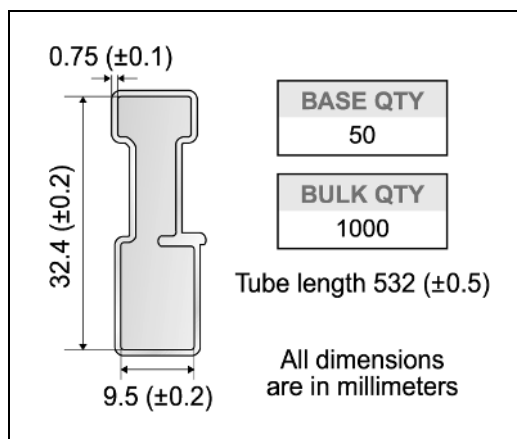

**TAPE AND REEL SHIPMENT (suffix "T4")\***

**TAPE MECHANICAL DATA**

DIM.	mm		inch	
	MIN.	MAX.	MIN.	MAX.
A0	10.5	10.7	0.413	0.421
B0	15.7	15.9	0.618	0.626
D	1.5	1.6	0.059	0.063
D1	1.59	1.61	0.062	0.063
E	1.65	1.85	0.065	0.073
F	11.4	11.6	0.449	0.456
K0	4.8	5.0	0.189	0.197
P0	3.9	4.1	0.153	0.161
P1	11.9	12.1	0.468	0.476
P2	1.9	2.1	0.075	0.082
R	50		1.574	
T	0.25	0.35	0.0098	0.0137
W	23.7	24.3	0.933	0.956

**REEL MECHANICAL DATA**

DIM.	mm		inch	
	MIN.	MAX.	MIN.	MAX.
A		330		12.992
B	1.5		0.059	
C	12.8	13.2	0.504	0.520
D	20.2		0.795	
G	24.4	26.4	0.960	1.039
N	100		3.937	
T		30.4		1.197

BASE QTY	BULK QTY
1000	1000

\* on sales type



Information furnished is believed to be accurate and reliable. However, STMicroelectronics assumes no responsibility for the consequences of use of such information nor for any infringement of patents or other rights of third parties which may result from its use. No license is granted by implication or otherwise under any patent or patent rights of STMicroelectronics. Specifications mentioned in this publication are subject to change without notice. This publication supersedes and replaces all information previously supplied. STMicroelectronics products are not authorized for use as critical components in life support devices or systems without express written approval of STMicroelectronics.

© The ST logo is a registered trademark of STMicroelectronics

© 2003 STMicroelectronics - Printed in Italy - All Rights Reserved  
STMicroelectronics GROUP OF COMPANIES

Australia - Brazil - Canada - China - Finland - France - Germany - Hong Kong - India - Israel - Italy - Japan - Malaysia - Malta - Morocco  
Singapore - Spain - Sweden - Switzerland - United Kingdom - United States.

© <http://www.st.com>