

PART NUMBER	REV	FIRST USED
680822-1	A	122500-1
680822-2	A	565435-5

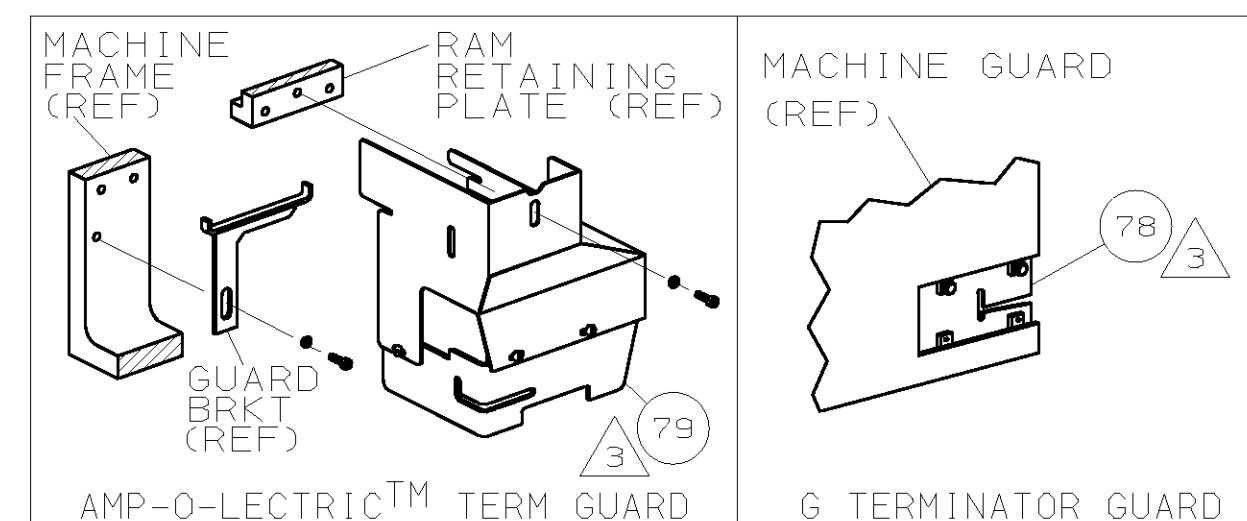

TERMINAL NAME: RECEPTACLE			
TERMINAL	SEAL	CRIMP DATA (NON-AMP TERMINAL-CUST SPEC)	
286807	286808	PAD LTR	CRIMP HEIGHT
		A .053 ±.002 [1.35 ±0.05mm]	16
		B .047 ±.002 [1.20 ±0.05mm]	18
		C .043 ±.002 [1.10 ±0.05mm]	20
		D	NOT USED
		CRIMP	SIZE
		WIRE .110 [2.79mm]	F
		INSUL .180 [4.57mm]	0
			φ.110 MAX
WIRE STRIP LENGTH	TERM APPL SPEC	FEED	APPL INSTRUCTION
.219-.250	NONE	.886	408-8039
			SET UP GAGE LAYOUT
			458638-1 L2234

-1 LEADMAKER & BENCH MODEL G		MECH POST FEED	
REF	REF	- A	22594-8
REF	REF	- B	240628-1
REF	REF	- B	240626-1
REF	REF	- B	240633-1
REF	REF	- A	455680-1
REF	REF	- B	240629-1
REF	REF	- A	240632-2
REF	REF	- B	240659-3
REF	REF	- B	240658-1
REF	REF	- B	454398-1
REF	REF	- C	454220-1
REF	REF	- D	453736-1
REF	REF	- B	240624-1
REF	REF	- B	691499-1
REF	REF	- B	240635-1
REF	REF	- B	240634-1
REF	REF	- C	690501-3
REF	REF	- B	690501-4
REF	REF	- A	690191-1
REF	REF	- C	455674-1
REF	REF	- A	690125-1
REF	REF	- A	690124-1
REF	REF	- A	7-21002-9
REF	REF	- A	23241-6
REF	REF	- A	690170-1
REF	REF	- C	690142-1
REF	REF	- D	354777-1
REF	REF	- A	22480-5
REF	REF	- B	690212-1
REF	REF	- A	458980-1
REF	REF	- B	3-690451-2
REF	REF	- A	240639-1
REF	REF	- C	455676-1
REF	REF	- A	22354-8
REF	REF	- B	455678-1
REF	REF	- C	240825-1
REF	REF	- A	4-22281-1
REF	REF	- A	454177-1
REF	REF	- C	454204-4
REF	REF	- A	454178-1
REF	REF	- A	4-22284-9
REF	REF	- C	690481-2
REF	REF	- A	23846-1
REF	REF	- B	240644-1
REF	REF	- B	690482-3
REF	REF	- D	3-356038-6
REF	REF	- B	690474-3
REF	REF	- D	2-455892-5
REF	REF	- C	1-240641-2
REF	REF	- B	238009-4
REF	REF	- C	7-683454-1
REF	REF	- B	2-455888-2
REF	REF	- C	456408-6

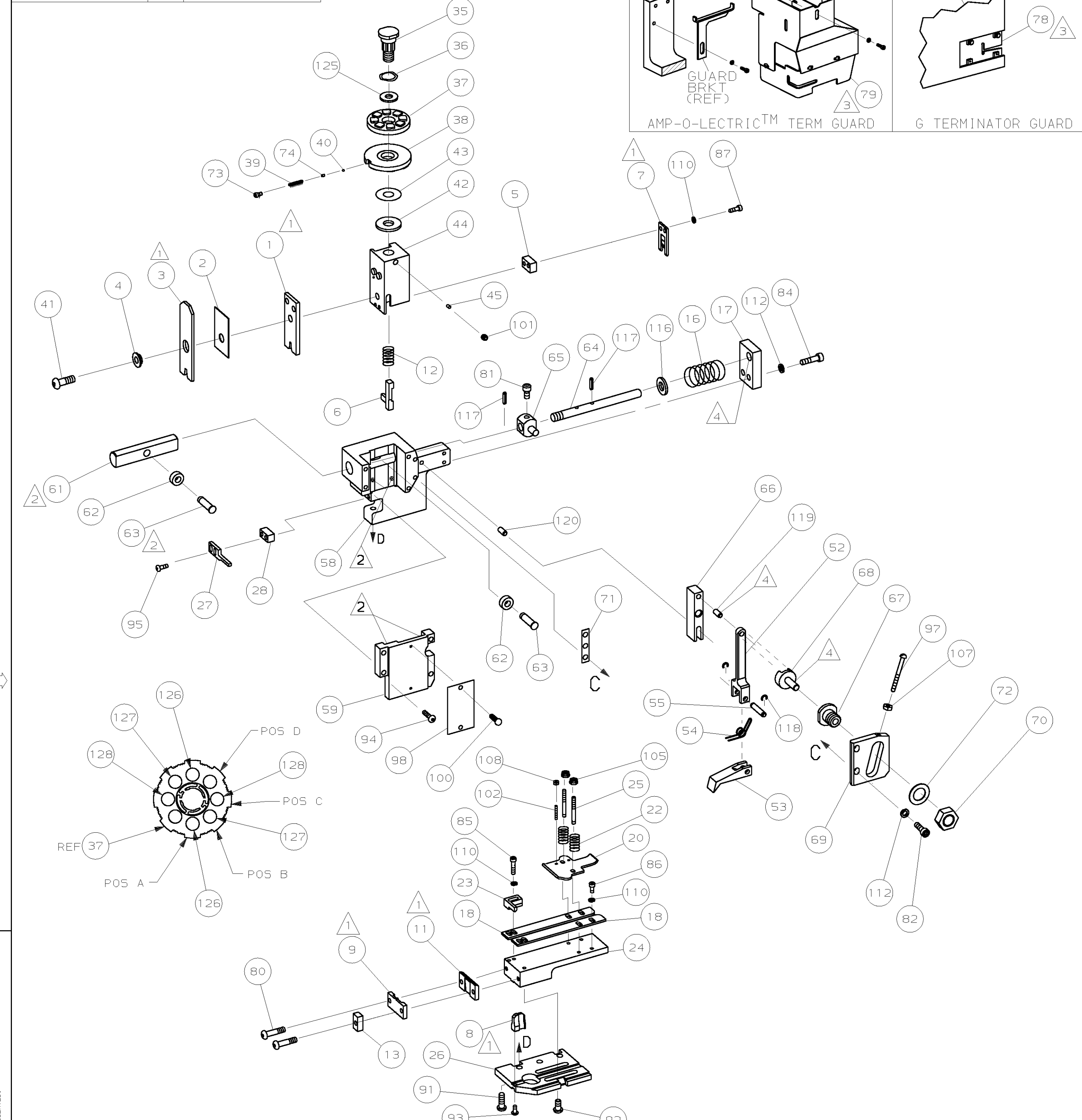

QTY	REF	REV	U/M	DWG SIZE	PART NO	DESCRIPTION	ITEM NO
2					5-354779-4	PIN, WIRE DISC (.3260)C	129
2					4-354779-2	PIN, WIRE DISC (.3200)B	128
2					3-354779-0	PIN, WIRE DISC (.3140)A	126
1					986950-1	WASHER, FLAT PRECISION	125
1					217238-1	GENERAL INSTRUCTION PACKAGE	124
1					4088039	EF APPL INST 408-8039	123
							122
							121
REF	REF	-	A		1-21030-7	PIN, DOWEL (φ.187x1.50)H5G	120
REF	REF	-	A		1-21030-1	PIN, DOWEL (φ.187x.50)LEVER	119
REF	REF	-	A		21045-3	RING, RET "C" (φ.187)FD PIN	118
REF	REF	-	A		5-21028-1	PIN, STD SPRING (φ.12)FD ADJ ROD	117
REF	REF	-	A		21899-4	WASHER, FLAT (φ5/16) SCR ADJ	116
							115
							114
							113
REF	REF	-	A		21024-5	WASHER, LOCK (NO.10)FD ROD GDE	112
7	7	-	A		21024-4	WASHER, LOCK (NO.8)SHEAR BL	110
							109
2	2	-	A		21018-4	NUT, HEX (4-40) DRAG	108
REF	REF	-	A		21018-5	NUT, HEX (6-32)FD ADJ PL	107
							106
2	2	-	A		21022-2	NUT, HEX SL (8-32)DRAG STUD	105
							104
							103
2	2	-	A		2-21006-6	SCR, SKT SET (4-40x.62) DRAG	102
1	1	-	A		21009-2	SCR, SKT SET (1/4-20x.25 )RAM	101
2	2	-	A		21017-2	SCR, DRIVE (#2x.19) ID PLATE	100
1	1	-	A		1-21002-7	SCR, BHC (6-32x.38) CAM	99
1	1	-	B		461264-1	PLATE, IDENTIFICATION	98
REF	REF	-	A		6-23715-5	SCR, PAN HD (8-32x1.50)FEED ADJ	97
							96
2	2	-	A		2-21002-2	SCR, BHC (8-32x.50) STRIPPER	95
REF	REF	-	A		2-21002-9	SCR, BHC (10-32x.75)H5G CAP	94
1	1	-	A		22733-8	SCR, BHC (8-32x.38 LW) ANVIL	93
4	4	-	A		3-21002-3	SCR, BHC (1/4-20x.50) ST 6D PL	92
REF	REF	-	A		2-22733-8	SCR, BHC (1/4-20x.62) BASE PL	91
							90
							89
							88
2	2	-	A		2-21000-7	SCR, 5HC (8-32x.50) SLUG BLADE	87
3	3	-	A		2-21000-6	SCR, 5HC (8-32x.38) R STP GUIDE	86
2	2	-	A		2-21000-9	SCR, 5HC (8-32x.75) R STP GUIDE	85
REF	REF	-	A		3-21000-7	SCR, 5HC (10-32x.75) FEED ROD GDE	84
							83
REF	REF	-	A		3-21000-6	SCR, 5HC (10-32x.62) FEED ADJ PL	82
REF	REF	-	A		3-21000-4	SCR, 5HC (10-32x.38) PIVOT BLOCK	81
2	2	-	A		3-21002-0	SCR, BHC (10-32x.88) SHEAR PL	80
REF	-	-	A		455745-1	GUARD, WINDOW	79
-	REF	-	A		679532-1	INSERT, GUARD	78
							77
							76
							75
1	1	-	A		690603-1	SPRING, ASSIST	74
1	1	-	A		23030-1	SCR, SKT CAP (6-32x.25) CP DSC	73
REF	REF	-	A		458109-1	WASHER, FLAT (SPECIAL)	72
REF	REF	-	A		690517-1	SPACER	71

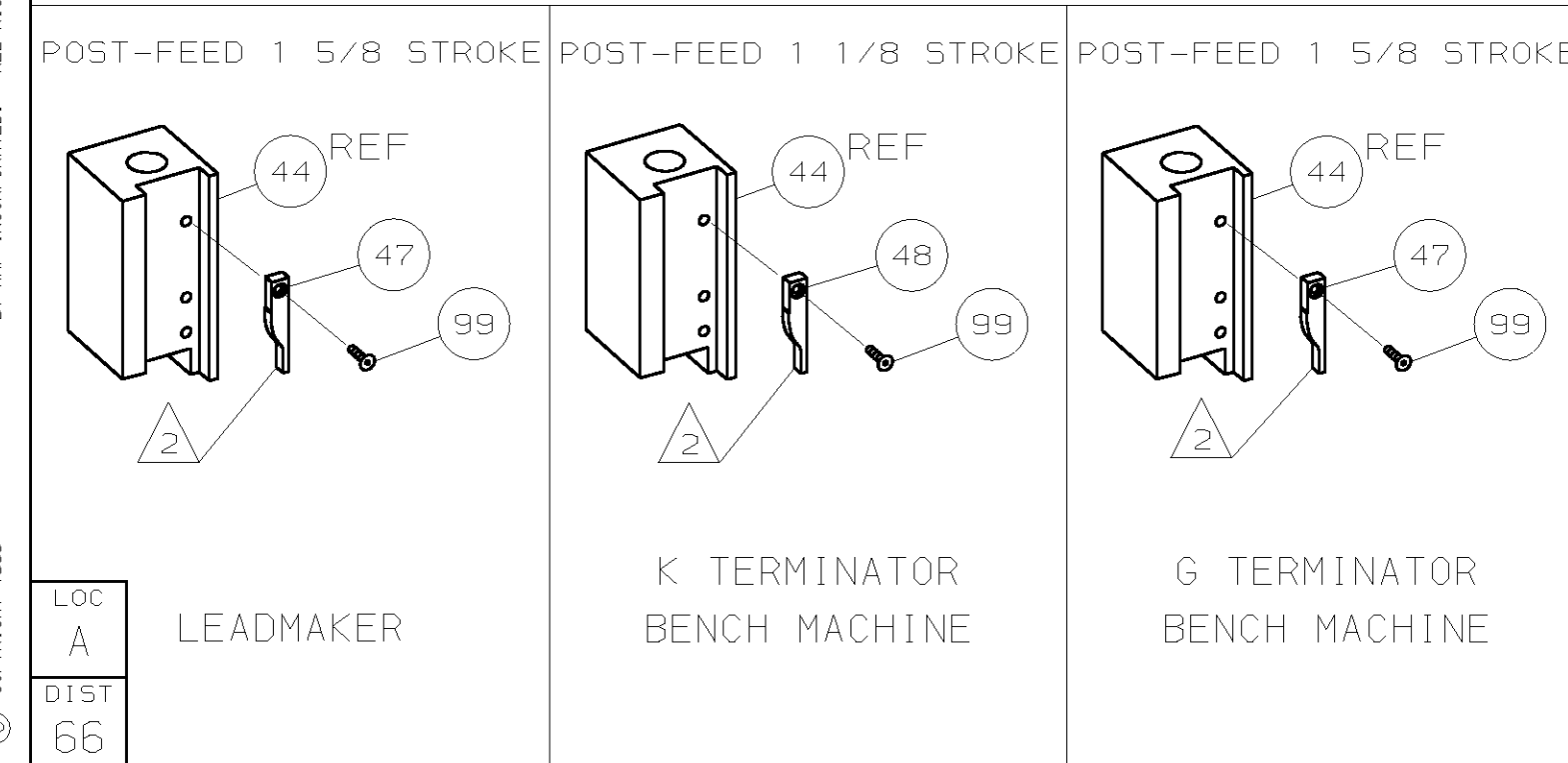

- 1 RECOMMENDED SPARE PARTS.
- 2 GREASE LIGHTLY.
- 3 GUARD MUST BE IN PLACE WHEN OPERATING APPLICATOR IN A BENCH MACHINE.
- 4 LUBRICATE DAILY USING NO. 20 MACHINE OIL.
- 5. ITEMS WITH QTY OF REF SPECIFIED (EXCEPT ITEMS 78 AND 79) ARE USED ON ITEM 32.
- 6 ITEM 78 USED WITH G TERMINATOR ONLY.
- 7 THIS APPLICATOR CRIMPS TERMINAL WITH A SEAL.

QTY	REF	REV	U/M	DWG SIZE	PART NO	DESCRIPTION	ITEM NO
-2	-1						

QTY	REF	REV	U/M	DWG SIZE	PART NO	DESCRIPTION	ITEM NO
1	1	-	A		690603-1	SPRING, ASSIST	74
1	1	-	A		23030-1	SCR, SKT CAP (6-32x.25) CP DSC	73
REF	REF	-	A		458109-1	WASHER, FLAT (SPECIAL)	72
REF	REF	-	A		690517-1	SPACER	71
-2	-1						

REVISION RECORD

REV	DATE	DESCRIPTION
A	REVISED	

SCALE: - D DWG NO: 680822

REVISION OF EACH ASSY NO (WHEN BLANK, USE DWG REVISION)

DR: W. HOOVER, 23APR99, APP: T. ELBIN, 23APR99

CHK: C. ERISMAN, 23APR99, REL: -

NAME: END FEED HDM APPLICATOR

SCALE: - D DWG NO: 680822

REVISION RECORD

REMOVED BURRS, BREAK SHARP EDGES R.015 MAX

SCALE: - D DWG NO: 680822

REVISION OF EACH ASSY NO (WHEN BLANK, USE DWG REVISION)

DR: W. HOOVER, 23APR99, APP: T. ELBIN, 23APR99

CHK: C. ERISMAN, 23APR99, REL: -

NAME: END FEED HDM APPLICATOR

SCALE: - D DWG NO: 680822

REVISION RECORD

REMOVED BURRS, BREAK SHARP EDGES R.015 MAX

SCALE: - D DWG NO: 680822

REVISION OF EACH ASSY NO (WHEN BLANK, USE DWG REVISION)

DR: W. HOOVER, 23APR99, APP: T. ELBIN, 23APR99

CHK: C. ERISMAN, 23APR99, REL: -

NAME: END FEED HDM APPLICATOR

SCALE: - D DWG NO: 680822

REVISION RECORD

REMOVED BURRS, BREAK SHARP EDGES R.015 MAX

SCALE: - D DWG NO: 680822

REVISION OF EACH ASSY NO (WHEN BLANK, USE DWG REVISION)

DR: W. HOOVER, 23APR99, APP: T. ELBIN, 23APR99

CHK: C. ERISMAN, 23APR99, REL: -

NAME: END FEED HDM APPLICATOR

SCALE: - D DWG NO: 680822

REVISION RECORD

REMOVED BURRS, BREAK SHARP EDGES R.015 MAX

SCALE: - D DWG NO: 680822

REVISION OF EACH ASSY NO (WHEN BLANK, USE DWG REVISION)

DR: W. HOOVER, 23APR99, APP: T. ELBIN, 23APR99

CHK: C. ERISMAN, 23APR99, REL: -

NAME: END FEED HDM APPLICATOR

SCALE: - D DWG NO: 680822

REVISION RECORD

REMOVED BURRS, BREAK SHARP EDGES R.015 MAX

SCALE: - D DWG NO: 680822

REVISION OF EACH ASSY NO (WHEN BLANK, USE DWG REVISION)

DR: W. HOOVER, 23APR99, APP: T. ELBIN, 23APR99

CHK: C. ERISMAN, 23APR99, REL: -

NAME: END FEED HDM APPLICATOR

SCALE: - D DWG NO: 680822

REVISION RECORD

REMOVED BURRS, BREAK SHARP EDGES R.015 MAX

SCALE: - D DWG NO: 680822

REVISION OF EACH ASSY NO (WHEN BLANK, USE DWG REVISION)

DR: W. HOOVER, 23APR99, APP: T. ELBIN, 23APR99

CHK: C. ERISMAN, 23APR99, REL: -

NAME: END FEED HDM APPLICATOR

SCALE: - D DWG NO: 680822

REVISION RECORD

REMOVED BURRS, BREAK SHARP EDGES R.015 MAX

SCALE: - D DWG NO: 680822

REVISION OF EACH ASSY NO (WHEN BLANK, USE DWG REVISION)

DR: W. HOOVER, 23APR99, APP: T. ELBIN, 23APR99

CHK: C. ERISMAN, 23APR99, REL: -

NAME: END FEED HDM APPLICATOR

SCALE: - D DWG NO: 680822

REVISION RECORD

REMOVED BURRS, BREAK SHARP EDGES R.015 MAX

SCALE: - D DWG NO: 680822

REVISION OF EACH ASSY NO (WHEN BLANK, USE DWG REVISION)

DR: W. HOOVER, 23APR99, APP: T. ELBIN, 23APR99

CHK: C. ERISMAN, 23APR99, REL: -

NAME: END FEED HDM APPLICATOR

SCALE: - D DWG NO: 680822

REVISION RECORD

REMOVED BURRS, BREAK SHARP EDGES R.015 MAX

SCALE: - D DWG NO: 680822

REVISION OF EACH ASSY NO (WHEN BLANK, USE DWG REVISION)

DR: W. HOOVER, 23APR99, APP: T. ELBIN, 23APR99

CHK: C. ERISMAN, 23APR99, REL: -

NAME: END FEED HDM APPLICATOR

SCALE: - D DWG NO: 680822

REVISION RECORD

REMOVED BURRS, BREAK SHARP EDGES R.015 MAX

SCALE: - D DWG NO: 680822

REVISION OF EACH ASSY NO (WHEN BLANK, USE DWG REVISION)

DR: W. HOOVER, 23APR99, APP: T. ELBIN, 23APR99

CHK: C. ERISMAN, 23APR99, REL: -

NAME: END FEED HDM APPLICATOR

SCALE: - D DWG NO: 680822

REVISION RECORD

REMOVED BURRS, BREAK SHARP EDGES R.015 MAX

SCALE: - D DWG NO: 680822

REVISION OF EACH ASSY NO (WHEN BLANK, USE DWG REVISION)

DR: W. HOOVER, 23APR99, APP: T. ELBIN, 23APR99

CHK: C. ERISMAN, 23APR99, REL: -

NAME: END FEED HDM APPLICATOR

SCALE: - D DWG NO: 680822

REVISION RECORD

REMOVED BURRS, BREAK SHARP EDGES R.015 MAX

SCALE: - D DWG NO: 680822

REVISION OF EACH ASSY NO (WHEN BLANK, USE DWG REVISION)

DR: W. HOOVER, 23APR99, APP: T. ELBIN, 23APR99

CHK: C. ERISMAN, 23APR99, REL: -

NAME: END FEED HDM APPLICATOR

SCALE: - D DWG NO: 680822

REVISION RECORD

REMOVED BURRS, BREAK SHARP EDGES R.015 MAX

SCALE: - D DWG NO: 680822

REVISION OF EACH ASSY NO (WHEN BLANK, USE DWG REVISION)

DR: W. HOOVER, 23APR99, APP: T. ELBIN, 23APR99

CHK: C. ERISMAN, 23APR99, REL: -

NAME: END FEED HDM APPLICATOR

SCALE: - D DWG NO: 680822

REVISION RECORD

REMOVED BURRS, BREAK SHARP EDGES R.015 MAX

SCALE: - D DWG NO: 680822

REVISION OF EACH ASSY NO (WHEN BLANK, USE DWG REVISION)

DR: W. HOOVER, 23APR99, APP: T. ELBIN, 23APR99

CHK: C. ERISMAN, 23APR99, REL: -

NAME: END FEED HDM APPLICATOR

SCALE: - D DWG NO: 680822

REVISION RECORD

REMOVED BURRS, BREAK SHARP EDGES R.015 MAX

SCALE: - D DWG NO: 680822

REVISION OF EACH ASSY NO (WHEN BLANK, USE DWG REVISION)

DR: W. HOOVER, 23APR99, APP: T. ELBIN, 23APR99

CHK: C. ERISMAN, 23APR99, REL: -

NAME: END FEED HDM APPLICATOR

SCALE: - D DWG NO: 680822

REVISION RECORD

REMOVED BURRS, BREAK SHARP EDGES R.015 MAX

SCALE: - D DWG NO: 680822

REVISION OF EACH ASSY NO (WHEN BLANK, USE DWG REVISION)

DR: W. HOOVER, 23APR99, APP: T. ELBIN, 23APR99

CHK: C. ERISMAN, 23APR99, REL: -

NAME: END FEED HDM APPLICATOR

SCALE: - D DWG NO: 680822

REVISION RECORD

REMOVED BURRS, BREAK SHARP EDGES R.015 MAX

SCALE: - D DWG NO: 680822

REVISION OF EACH ASSY NO (WHEN BLANK, USE DWG REVISION)

DR: W. HOOVER, 23APR99, APP: T. ELBIN, 23APR99

CHK: C. ERISMAN, 23APR99, REL: -

NAME: END FEED HDM APPLICATOR

SCALE: - D DWG NO: 680822

REVISION RECORD

REMOVED BURRS, BREAK SHARP EDGES R.015 MAX

SCALE: - D DWG NO: 680822

REVISION OF EACH ASSY NO (WHEN BLANK, USE DWG REVISION)

DR: W. HOOVER, 23APR99, APP: T. ELBIN, 23APR99

CHK: C. ERISMAN, 23APR99, REL: -

NAME: END FEED HDM APPLICATOR

SCALE: - D DWG NO: 680822

REVISION RECORD

REMOVED BURRS, BREAK SHARP EDGES R.015 MAX

SCALE: - D DWG NO: 680822

REVISION OF EACH ASSY NO (WHEN BLANK, USE DWG REVISION)

DR: W. HOOVER, 23APR99, APP: T. ELBIN, 23APR99

CHK: C. ERISMAN, 23APR99, REL: -

NAME: END FEED HDM APPLICATOR

SCALE: - D DWG NO: 680822

REVISION RECORD

REMOVED BURRS, BREAK SHARP EDGES R.015 MAX

SCALE: - D DWG NO: 680822

REVISION OF EACH ASSY NO (WHEN BLANK, USE DWG REVISION)

DR: W. HOOVER, 23APR99, APP: T. ELBIN, 23APR99

CHK: C. ERISMAN, 23APR99, REL: -

NAME: END FEED HDM APPLICATOR

SCALE: - D DWG NO: 680822

REVISION RECORD

REMOVED BURRS, BREAK SHARP EDGES R.015 MAX

SCALE: - D DWG NO: 680822

REVISION OF EACH ASSY NO (WHEN BLANK, USE DWG REVISION)

DR: W. HOOVER, 23APR99, APP: T. ELBIN, 23APR99

CHK: C. ERISMAN, 23APR99, REL: -

NAME: END FEED HDM APPLICATOR

SCALE: - D DWG NO: 680822

REVISION RECORD

REMOVED BURRS, BREAK SHARP EDGES R.015 MAX

SCALE: - D DWG NO: 680822

REVISION OF EACH ASSY NO (WHEN BLANK, USE DWG REVISION)

DR: W. HOOVER, 23APR99, APP: T. ELBIN, 23APR99

CHK: C. ERISMAN, 23APR99, REL: -

NAME: END FEED HDM APPLICATOR

SCALE: - D DWG NO: 680822

REVISION RECORD

REMOVED BURRS, BREAK SHARP EDGES R.015 MAX

SCALE: - D DWG NO: 680822

REVISION OF EACH ASSY NO (WHEN BLANK, USE DWG REVISION)

DR: W. HOOVER, 23APR99, APP: T. ELBIN, 23APR99

CHK: C. ERISMAN, 23APR99, REL: -

NAME: END FEED HDM APPLICATOR

SCALE: - D DWG NO: 680822

REVISION RECORD

REMOVED BURRS, BREAK SHARP EDGES R.015 MAX

SCALE: - D DWG NO: 680822

REVISION OF EACH ASSY NO (WHEN BLANK, USE DWG REVISION)

DR: W. HOOVER, 23APR99, APP: T. ELBIN, 23APR99

CHK: C. ERIS