

APPROVED: _____

DATE: _____ TITLE: _____

Rev	AWO #	Description	Date	Appr
-		RELEASED	11/20/20	

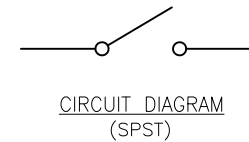
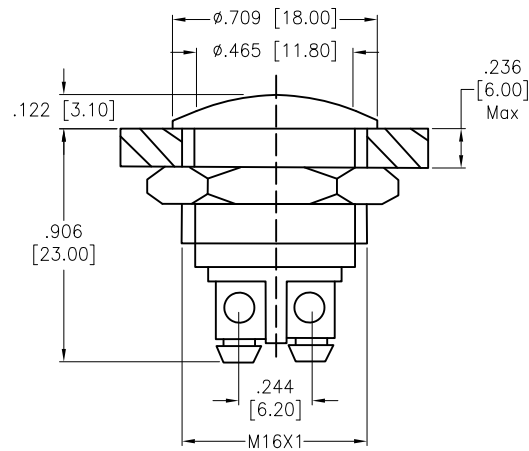
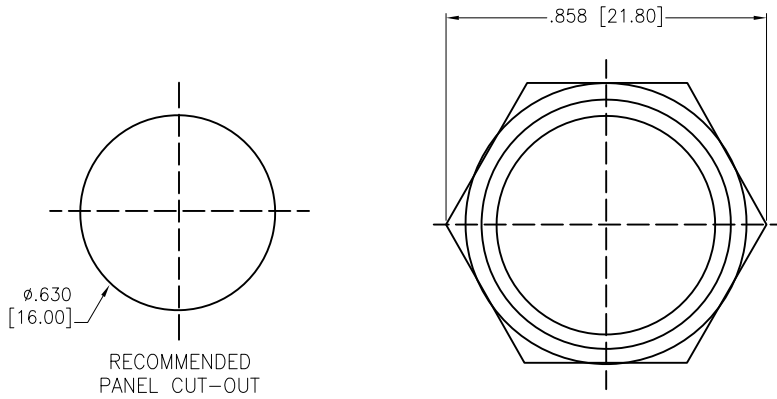

SPECIFICATIONS:

Material:

Base: PBT, rated UL 94V-0

Contact: Silver plated

Nut: Brass, Nickel plated

Button: Stainless steel or Copper plating chrome

Bushing & Bezel: Stainless steel or Copper plating chrome

Electrical:

Rating: 3A @ 250V AC

Contact resistance: 50 mΩ max

Insulation resistance: 1000 MΩ min

Dielectric withstanding voltage: 2000V AC for 1 minute

Electrical Life: 50,000 cycles

Temperature Rating:

Operating temperature: -25°C to +85°C

Environmental:

Lead free, RoHS compliant



UNLESS OTHERWISE SPECIFIED ALL DIMENSIONS ARE INCHES [MM]. TOLERANCES: EXCEPT AS NOTED

INCHES		HOLES	
.X	± .10	Ø.X	± .10
.XX	± .020	Ø.XX	± .015
.XXX	± .015	Ø.XXX	± .010

DRAWN	OW	11/25/20
CHECKED	AC	11/25/20
APPROVED		

THIS DRAWING CONTAINS INFORMATION THAT IS PROPRIETARY AND SHOULD NOT BE USED WITHOUT PRIOR WRITTEN PERMISSION FROM ADAM TECH

ADAM TECH

909 Rahway Avenue,
Union, NJ 07083
Phone: 908-687-5000
Fax: 908-687-5710

TITLE		SWITCH, ANTI-VANDAL SWITCH, SPST, MOMENTARY, SCREW LUG	
SIZE	PART NO.	REF:	REV.
X	SW-PB7-1S-D-G1	S00204C	-
SCALE: NTS		SHEET 1 OF 1	