



Silicon Oscillator with Reset Output

MAX7376

General Description

The MAX7376 silicon oscillator with reset, is a replacement for ceramic resonators, crystals, crystal oscillator modules, and discrete reset circuits. The MAX7376 provides the primary clock source and reset function for microcontrollers in 3V, 3.3V, and 5V applications. The MAX7376 features a factory-programmed high-speed oscillator and a microprocessor (μ P) power-on-reset (POR) supervisor.

Unlike typical crystal and ceramic resonator oscillator circuits, the MAX7376 is resistant to vibration and EMI. The high-output-drive current and absence of high-impedance nodes make the oscillator less susceptible to dirty or humid operating conditions. With a wide operating temperature range as standard, the MAX7376 is a good choice for demanding home appliance, industrial, and automotive environments.

The MAX7376 is available in factory-programmed frequencies from 32.768kHz to 10MHz. See Table 2 for standard frequencies and contact the factory for custom frequencies.

The MAX7376 is available in a 5-pin SOT23 package. Refer to the MAX7382 data sheet for frequencies ≥ 10 MHz. The MAX7376 standard operating temperature range is -40°C to $+125^{\circ}\text{C}$. See the *Applications Information* section for the extended operating temperature range.

Applications

White Goods
Automotive
Consumer Products
Appliances and Controls
Handheld Products
Portable Equipment
Microcontroller (μ C) Systems

Typical Application Circuit appears at end of data sheet.

Features

- ◆ 2.7V to 5.5V Operation
- ◆ Accurate Oscillator: 600kHz to 10MHz or 32kHz
- ◆ Reset Output Holds the μ C in Reset for 100 μ s After Clock Startup
- ◆ ± 10 mA Clock Output Drive Capability
- ◆ 2% Initial Accuracy
- ◆ ± 50 ppm/ $^{\circ}\text{C}$ Temperature Coefficient
- ◆ 50% Duty Cycle
- ◆ 5ns Output Rise and Fall Time
- ◆ Low Jitter: 160ps_{P-P} at 8MHz (No PLL)
- ◆ 3mA Operating Current (8MHz)
- ◆ 13 μ A Operating Current (32kHz)
- ◆ -40°C to $+125^{\circ}\text{C}$ Temperature Range

Ordering Information

PART	TEMP RANGE	PIN-PACKAGE	RESET OUTPUT
MAX7376C ___-T	-40°C to $+125^{\circ}\text{C}$	5 SOT23-5	Open drain
MAX7376A___-T	-40°C to $+125^{\circ}\text{C}$	5 SOT23-5	Active high push-pull
MAX7376B___-T	-40°C to $+125^{\circ}\text{C}$	5 SOT23-5	Active low push-pull

Standard version is shown in bold.

The first letter after the part number designates the reset output option. Insert the letter corresponding to the desired reset threshold level from Table 1 in the next position. Insert the two-letter code from Table 2 in the remaining two positions for the desired frequency range. See Table 3 for standard part numbers.

Pin Configuration

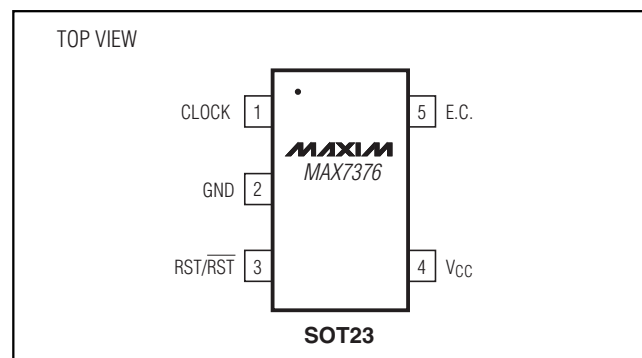

Silicon Oscillator with Reset Output

ABSOLUTE MAXIMUM RATINGS

V _{CC} to GND	-0.3V to +6V	Operating Temperature Range	-40°C to +135°C
All Other Pins to GND	-0.3V to (V _{CC} + 0.3V)	Junction Temperature	+150°C
CLOCK Current	±10mA	Storage Temperature Range.....	-60°C to +150°C
Continuous Power Dissipation (T _A = +70°C)		Lead Temperature (soldering, 10s).....	+300°C
5-Pin SOT23			
(derate 7.1mW/°C above +70°C)	571mW (U5 - 2)		

Stresses beyond those listed under "Absolute Maximum Ratings" may cause permanent damage to the device. These are stress ratings only, and functional operation of the device at these or any other conditions beyond those indicated in the operational sections of the specifications is not implied. Exposure to absolute maximum rating conditions for extended periods may affect device reliability.

ELECTRICAL CHARACTERISTICS

(V_{CC} = 2.7V to 5.5V, T_A = -40°C to +125°C, unless otherwise noted. Typical values are at V_{CC} = 5V and T_A = +25°C.) (Note 1)

PARAMETER	SYMBOL	CONDITIONS	MIN	TYP	MAX	UNITS
Operating Supply Voltage	V _{CC}		2.7		5.5	V
Operating Supply Current	I _{CC}	f _{CLOCK} = 8MHz, no load		3	5	mA
		f _{CLOCK} = 32.768kHz, no load		13	25	µA
CLOCK OUTPUT						
Minimum Operating Voltage				1.65		V
Output High Voltage	V _{OH}	V _{CC} = 4.5V, I _{SOURCE} = 9mA	V _{CC}		-0.4	V
		V _{CC} = 2.7V, I _{SOURCE} = 2.5mA	V _{CC}		-0.4	
Output Low Voltage	V _{OL}	V _{CC} = 4.5V, I _{SINK} = 20mA			0.4	V
		V _{CC} = 2.7V, I _{SINK} = 10mA			0.4	
Initial Frequency Accuracy	f _{CLOCK}	V _{CC} = 5V, T _A = +25°C (Note 2)	-2		+2	%
		V _{CC} = 2.7V to 5.5V, T _A = +25°C	-4		+4	
Frequency Temperature Sensitivity		(Note 3)		±50	±325	ppm/°C
Initial Frequency Accuracy (32.768kHz)	f _{CLOCK}	V _{CC} = 5V, T _A = +25°C (Note 2)	32.440	32.768	33.096	kHz
		V _{CC} = 2.7V to 5.5V, T _A = +25°C	31.785		33.751	
Frequency Temperature Sensitivity		32.768kHz (Note 3)		±50	±325	ppm/°C
CLOCK Output Duty Cycle			43	50	57	%
CLOCK Output Jitter		Observation of 8MHz output for 20s using a 500MHz oscilloscope		160		pSp-p
CLOCK Output Rise Time	t _R	10% to 90%		5		ns
CLOCK Output Fall Time	t _F	90% to 10%		5		ns

Silicon Oscillator with Reset Output

MAX7376

ELECTRICAL CHARACTERISTICS (continued)

($V_{CC} = 2.7V$ to $5.5V$, $T_A = -40^{\circ}C$ to $+125^{\circ}C$, unless otherwise noted. Typical values are at $V_{CC} = 5V$ and $T_A = +25^{\circ}C$.) (Note 1)

PARAMETER	SYMBOL	CONDITIONS	MIN	TYP	MAX	UNITS
RST/\overline{RST} OUTPUT						
Reset Threshold	V_{TH+}	V_{CC} rising	$T_A = +25^{\circ}C$	$V_{TH} - 2\%$	$V_{TH} + 2\%$	V
			$T_A = -40^{\circ}C$ to $+125^{\circ}C$	$V_{TH} - 5\%$	$V_{TH} + 5\%$	
Reset Hysteresis	V_{THYS}	$V_{HYST} = \{(V_{TH+}) - (V_{TH-})\} / (V_{TH-}) \times 100\%$		2.0		%
POR Delay		V_{CC} rising from 0V to $(V_{TH} + 200mV)$ in $1\mu s$		100		μs
Output High Voltage	V_{OH}	$V_{CC} = 4.5V$, $I_{SOURCE} = 9mA$	$V_{CC} - 0.4$			V
		$V_{CC} = 2.7V$, $I_{SOURCE} = 2.5mA$	$V_{CC} - 0.4$			
Output Low Voltage	V_{OL}	$V_{CC} = 4.5V$, $I_{SINK} = 20mA$	0.4			V
		$V_{CC} = 2.7V$, $I_{SINK} = 10mA$	0.4			
Leakage Current	I_{LEAK}	$V_{CC} = 5.5V$, $V_{RST} = 5.5V$, open drain			1	μA

Note 1: All parameters are tested at $T_A = +25^{\circ}C$. Specifications over temperature are guaranteed by design.

Note 2: The frequency is determined by part number selection. See Table 3.

Note 3: Guaranteed by design. Not production tested.

Typical Operating Characteristics

($V_{CC} = 5V$, $T_A = +25^{\circ}C$, unless otherwise noted.)

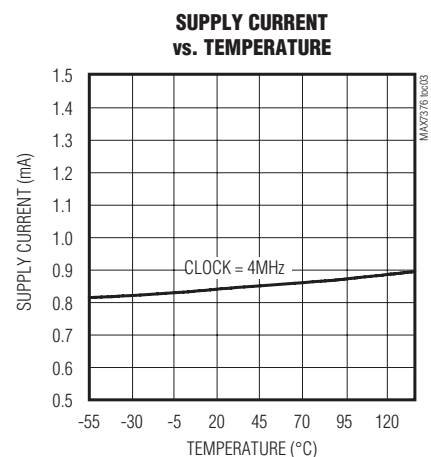
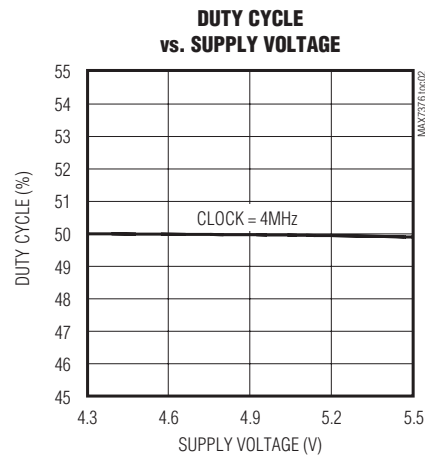
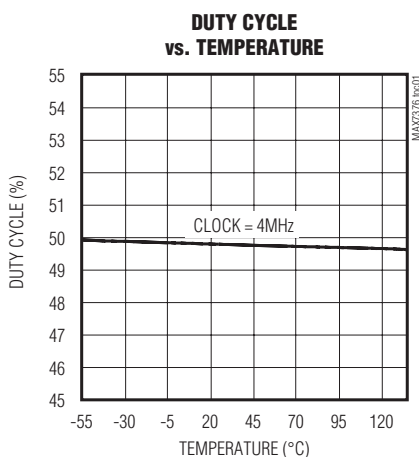

Silicon Oscillator with Reset Output

Typical Operating Characteristics (continued)

($V_{CC} = 5V$, $T_A = +25^\circ C$, unless otherwise noted.)

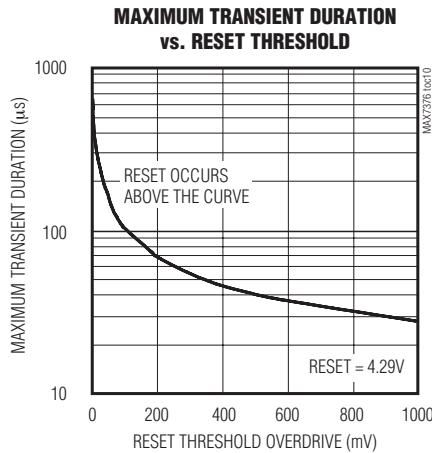
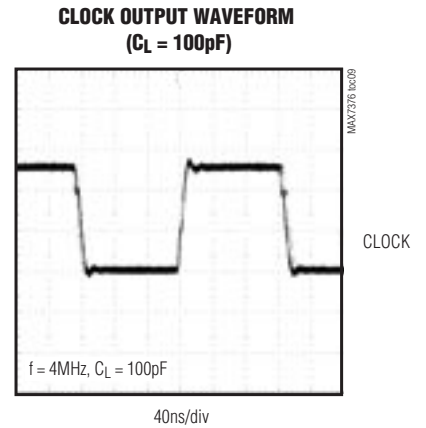
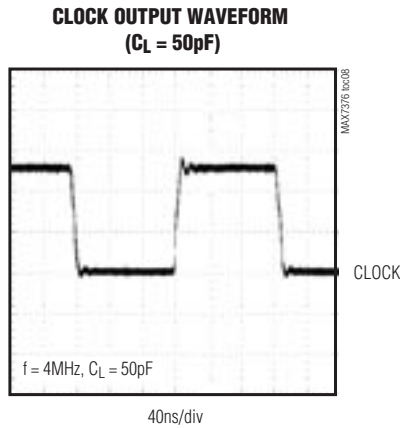
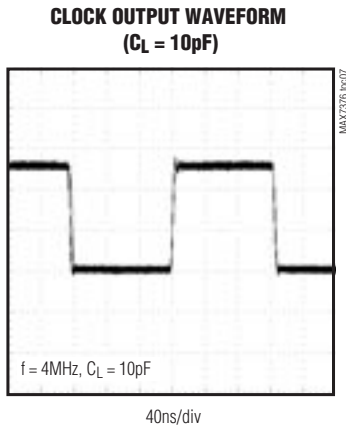
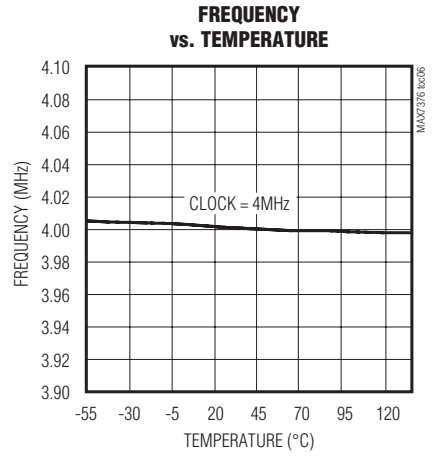
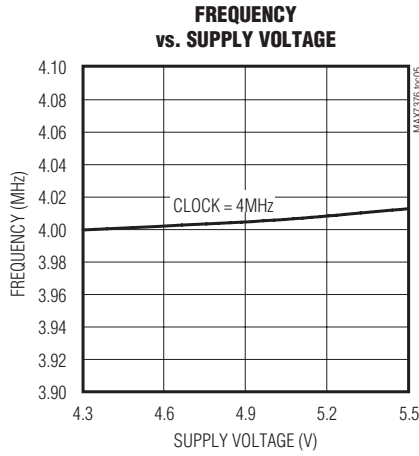
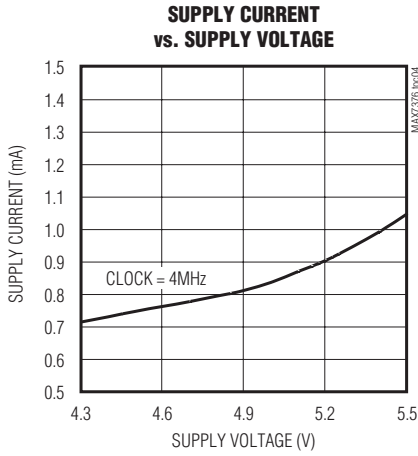

Silicon Oscillator with Reset Output

Pin Description

PIN	NAME	FUNCTION
1	CLOCK	Push-Pull Clock Output
2	GND	Ground
3	RST	Reset Output. See the <i>RST Reset Output Options</i> section for more details.
4	V _{CC}	Positive Supply Voltage. Bypass V _{CC} to GND with a 0.1μF capacitor.
5	E.C.	Must Be Externally Connected to V _{CC}

Detailed Description

The MAX7376 is a clock generator with integrated reset for μCs and UARTs in 3V, 3.3V, and 5V applications (Figure 1). The MAX7376 is a replacement for crystal oscillator modules, crystals, or ceramic resonators and a system-reset IC. The clock frequency is factory trimmed to specific values. A variety of popular standard frequencies are available (Table 2). No external components are required for setting or adjusting the frequency.

Supply Voltage

The MAX7376 has been designed for use in systems with nominal supply voltages of 3V, 3.3V, or 5V and is specified for operation with supply voltages in the 2.7V to 5.5V range. See the *Absolute Maximum Ratings* section for limit values of power-supply and pin voltages.

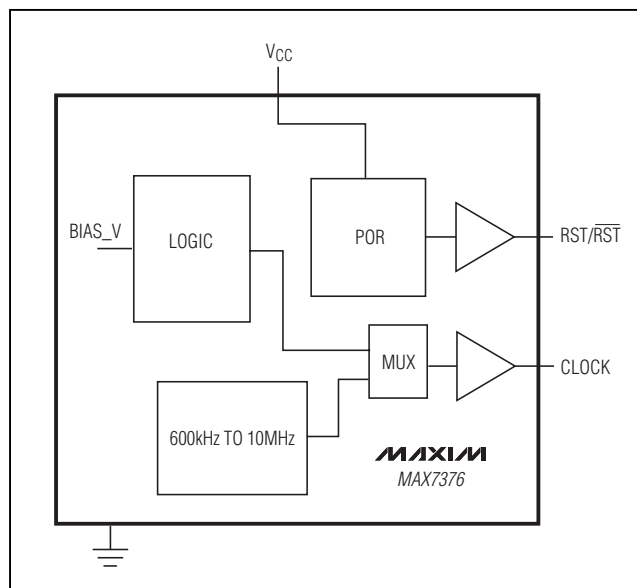

Figure 1. Functional Diagram

Oscillator

The clock output is a push-pull configuration and is capable of driving a ground-connected 500Ω or a positive-supply-connected 250Ω load to within 400mV of either supply rail. The clock output remains stable over the full operating voltage range and does not generate short output cycles during either power-on or power-off. A typical startup characteristic is shown in the *Typical Operating Characteristics*.

Applications Information

Interfacing to a μC Clock Input

The MAX7376 clock output is a push-pull, CMOS, logic output that directly drives any μP or μC clock input. There are no impedance-matching issues when using the MAX7376. The MAX7376 is not sensitive to its position on the board and it does not need to be placed right next to the μP. Refer to the μC data sheet for clock-input compatibility with external clock signals. The MAX7376 requires no biasing components or load capacitance. When using the MAX7376 to retrofit a crystal oscillator, remove all biasing components from the oscillator input.

RST Reset Output Options

The MAX7376 is available with three reset output stage options: push-pull with active-low output, push-pull with active-high output, and open drain with active-low output. The RST output is asserted when the monitored input (V_{CC}) drops below the internal V_{TH-} threshold and remains asserted for 100μs after the monitored input exceeds the internal V_{TH+} threshold. The open-drain RST output requires an external pullup resistor.

Output Jitter

The MAX7376's jitter performance is given in the *Electrical Characteristics* table as a peak-to-peak value obtained by observing the output of the MAX7376 for 20s with a 500MHz oscilloscope. Jitter values are approximately proportional to the period of the output frequency of the device. Thus, a 4MHz part has approximately twice the jitter value of an 8MHz part. The jitter performance of clock sources degrades in the presence of mechanical and electrical interference.

Silicon Oscillator with Reset Output

The MAX7376 is relatively immune to vibration, shock, and EMI influences, and thus provides a considerably more robust clock source than crystal or ceramic resonator-based oscillator circuits.

Initial Power-Up and Operation

The clock starts up within 30 μ s (typ) after V_{CC} has risen above the reset threshold. The reset output remains asserted for 100 μ s after the reset threshold is reached.

Extended Temperature Operation

The MAX7376 was tested to +135°C during product characterization and shown to function normally at this temperature (see the *Typical Operating Characteristics*). However, production test and qualification is only performed from -40°C to +125°C at this time. Contact the factory if operation outside this range is required.

Power-Supply Considerations

The MAX7376 operates with a 2.7V and 5.5V power-supply voltage. Good power-supply decoupling is needed to maintain the power-supply rejection performance of the MAX7376. Bypass V_{CC} to GND with a 0.1 μ F surface-mount ceramic capacitor. Mount the bypass capacitor as close to the device as possible. If possible, mount the MAX7376 close to the μ C's decoupling capacitor so that additional decoupling is not required. A larger value bypass capacitor is recommended if the MAX7376 is to operate with a large capacitive load. Use a bypass capacitor value of at least 1000 times that of the output load capacitance.

Table 1. Standard Reset Threshold Levels

SUFFIX	RESET THRESHOLD (V)
R	2.57
M	4.29

For all other reset threshold options, contact factory.

Table 2. Standard Frequencies

SUFFIX	STANDARD FREQUENCY (MHz)
AA	32.768kHz
MG	1
OK	1.8432
QT	3.39545
QW	3.6864
RD	4
RH	4.1943
TP	8

For all other reset threshold options, contact factory.

Typical Application Circuit

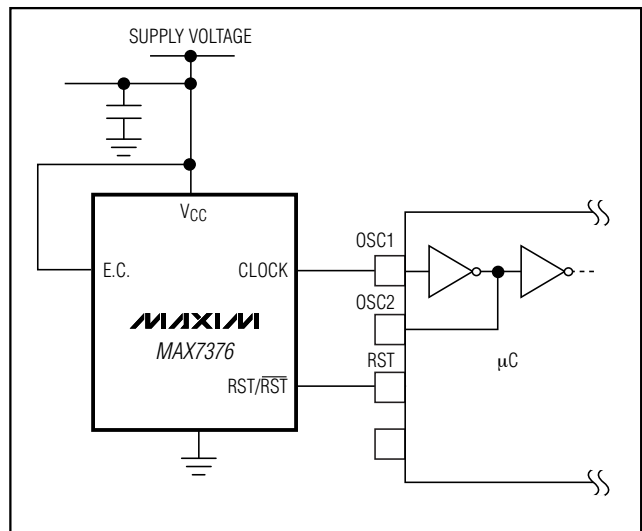

Silicon Oscillator with Reset Output

MAX7376

Table 3. Standard Part Numbers

PART	PIN-PACKAGE	RESET THRESHOLD (V)	FREQUENCY (Hz)	TOP MARK
MAX7376CRAA	5 SOT23	2.57	32.768k	AEUZ
MAX7376CRMG	5 SOT23	2.57	1M	AEUN
MAX7376CROK	5 SOT23	2.57	1.8432M	AEUJ
MAX7376CRQT	5 SOT23	2.57	3.39545M	AETT
MAX7376CRQW	5 SOT23	2.57	3.6864M	AETU
MAX7376CRRD	5 SOT23	2.57	4M	AETV
MAX7376CRRH	5 SOT23	2.57	4.1943M	AETW
MAX7376CRTP	5 SOT23	2.57	8M	AESF
MAX7376CMMG	5 SOT23	4.29	1M	AEUM
MAX7376CMOK	5 SOT23	4.29	1.8432M	AEUI
MAX7376CMQT	5 SOT23	4.29	3.39545M	AESH
MAX7376CMQW	5 SOT23	4.29	3.6864M	AETP
MAX7376CMRD	5 SOT23	4.29	4M	AESJ
MAX7376CMRH	5 SOT23	4.29	4.1943M	AETR
MAX7376CMTP	5 SOT23	4.29	8M	AETS

Chip Information

TRANSISTOR COUNT: 2027

PROCESS: BICMOS

Silicon Oscillator with Reset Output

Package Information

(The package drawing(s) in this data sheet may not reflect the most current specifications. For the latest package outline information go to www.maxim-ic.com/packages.)

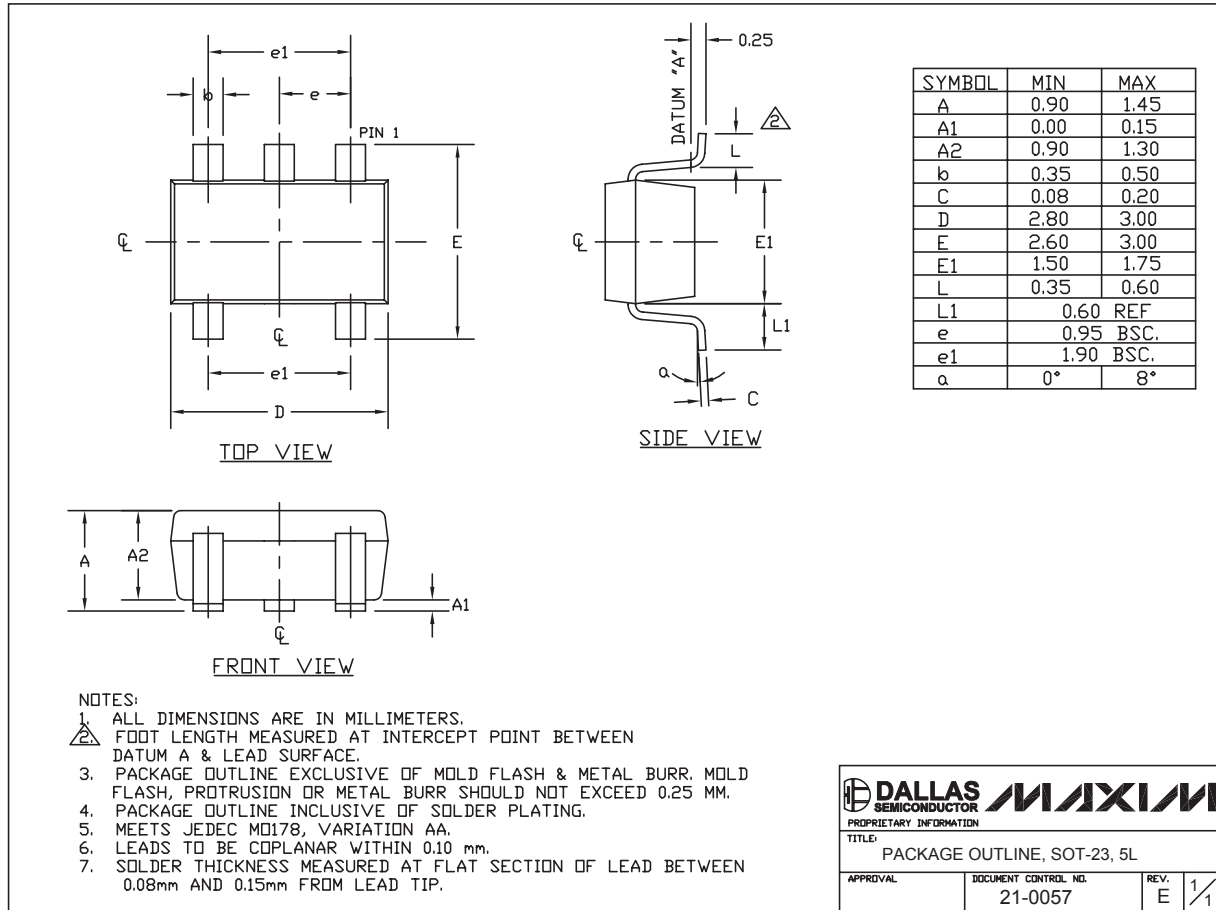

SOT-23 5L .EPS

DALLAS SEMICONDUCTOR **MAXIM**
 PROPRIETARY INFORMATION
 TITLE: PACKAGE OUTLINE, SOT-23, 5L
 APPROVAL: _____ DOCUMENT CONTROL NO. 21-0057 REV. E 1/1

Maxim cannot assume responsibility for use of any circuitry other than circuitry entirely embodied in a Maxim product. No circuit patent licenses are implied. Maxim reserves the right to change the circuitry and specifications without notice at any time.

8 Maxim Integrated Products, 120 San Gabriel Drive, Sunnyvale, CA 94086 408-737-7600