

4

3

2

DWG NO. GE-2157 SH 1 REV D

1

PROPRIETARY NOTICE: THE INFORMATION CONTAINED IN THIS DOCUMENT IS PROPRIETARY TO AMPHENOL AND SHALL NOT BE DISCLOSED IN WHOLE OR IN PART IN ANY FORM OR FOR ANY REASON EXCEPT AS EXPRESSLY STATED IN WRITING BY AMPHENOL.

- NOTES:
1. CONTINUOUS OPERATING TEMPERATURE -40°C TO 150°C
 2. CONNECTOR: METRI-PACK 150.2 OR GT150 3.5mm  MATING APTIV(DELPHI) NUMBER:12162193,15336004, OR EQUIVILANT
 3. VOLTAGE: 5V
 4. SENSOR INSTALATION TORQUE: TIGHTEN PROBES TO 20Nm TO 25Nm REFERENCE
 5. LOCTITE 503,516 OR 517 THREAD SEALANT APPLIED TO THE THREADS

TEMP (°C)	RESISTANCE (OHMS)	RES TOL (±%)
-40	100865	4.87
25	2795	2.50
50	980.3	2.27
85	283.5	2.00
125	88.3	2.75
128	81.7	2.77
150	47.5	2.90

REVISIONS				
REV	REVISION HISTORY	DATE	DWN	APVD
A	INITIAL RELEASE	06/01/18	MED	JD
B	85°C WAS 80°C ADDED 128°C ROW ADDED NOTES #4 & #5	11/01/18	MED	JD
C	ADDED NOTE#5 THEAD SEALENT NOTE#6 WAS #5	11/29/18	MED	JD
D	UPDATED NOTES,ULTEM 2300-BLACK WAS NYLON 66 GF 33% 27.0+/- .5WAS 27.00,8.3+/- .15 WAS 8.30	5/30/19	MED	STS

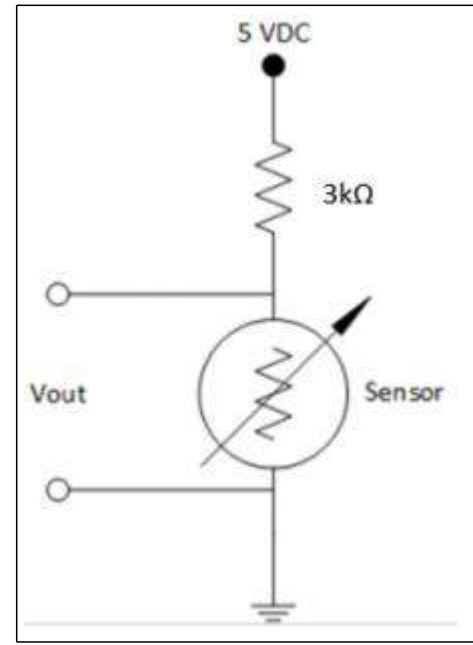
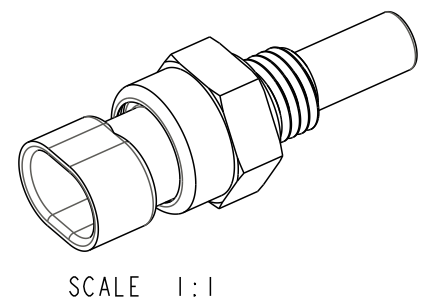
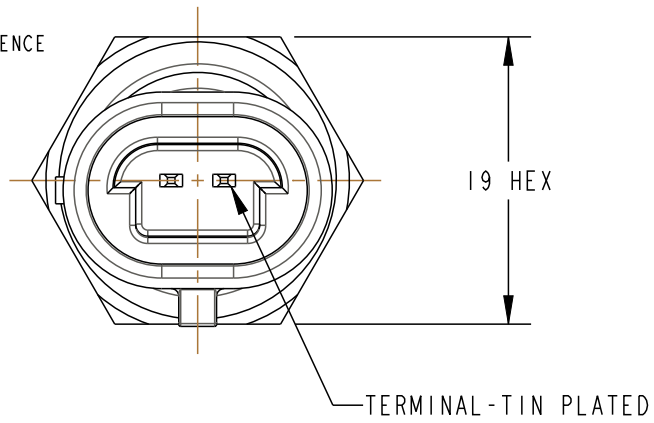

TYPICAL 25°C CIRCUIT

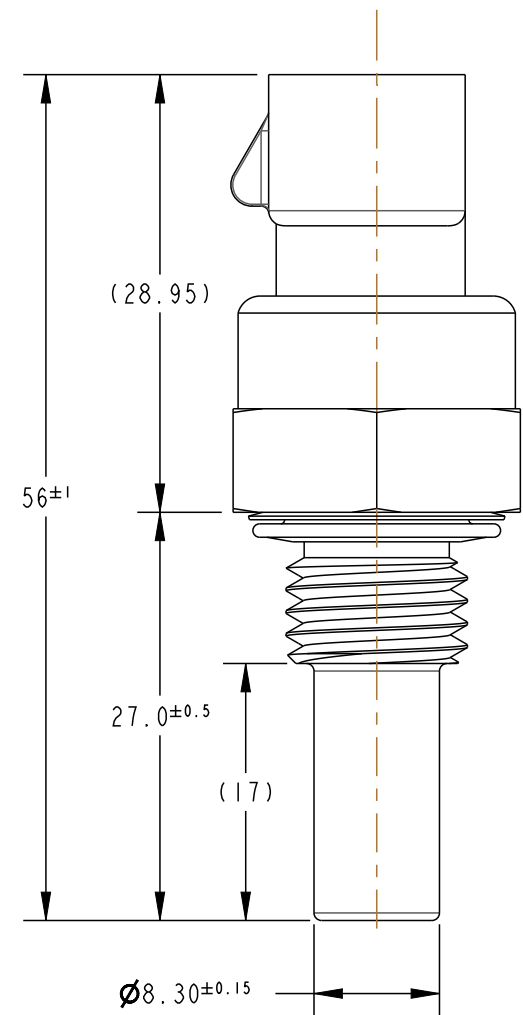
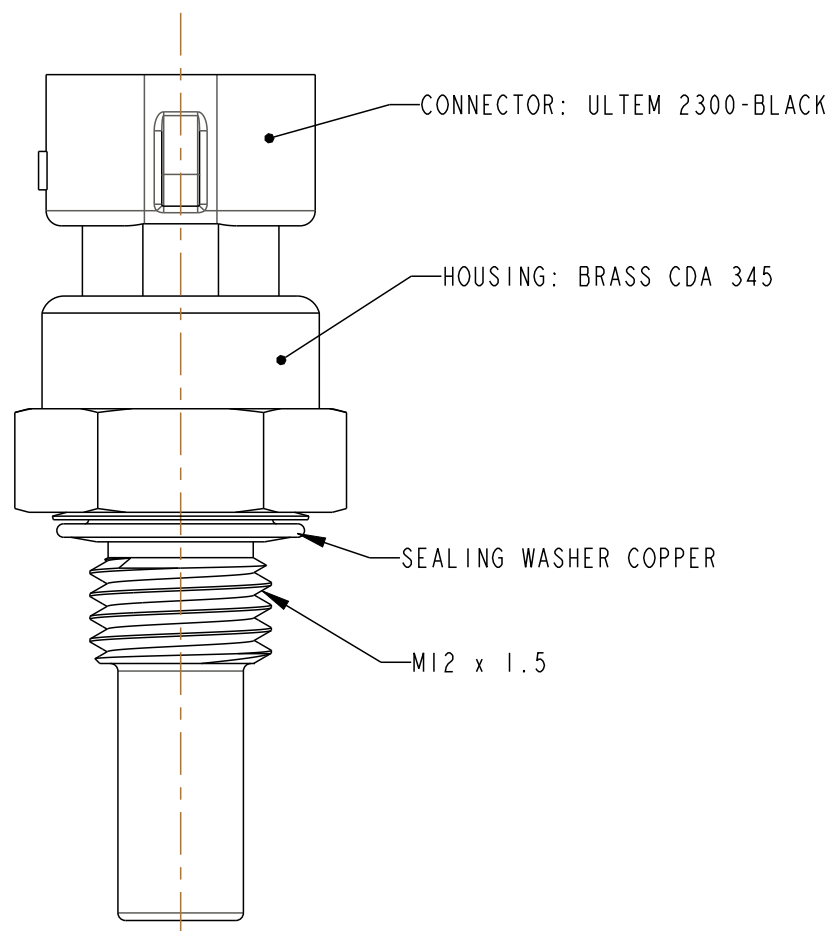

Amphenol
Advanced Sensors St. Marys, PA 15857

TITLE: FLUID TEMPERATURE SENSOR

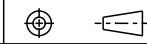
UNLESS OTHERWISE SPECIFIED DIMENSIONS ARE IN MM TOLERANCES ARE: .X ± 0.5 .XX ± 0.25	APPROVALS	DATE
	DRAWN DAM/MED	06/01/18
THIRD ANGLE PROJECTION 	CHECKED STS	06/01/2018
	ENGR JD	06/01/2018
INTERPRET DRAWING IAW ASME Y14.5	OC	
MATERIAL SEE DRAWING	MFG	

DO NOT SCALE DRAWING

SIZE B DWG NO. GE-2157 REV D

SCALE 2:1 SHEET 1 OF 1

LEGAL NOTICE - THIS DRAWING AND ANY INTELLECTUAL PROPERTY RIGHTS THERE IN ARE PROPERTY OF AMPHENOL AND NO LICENSES ARE GRANTED UNDER THOSE RIGHTS.

4

3

2

1